



RECEIVING • INSTALLATION • OPERATION INSTRUCTIONS

TEMPERATURE INDICATOR

Hottest Spot Resistance Bridge Type

Wall Mounted

Switchboard Indicating

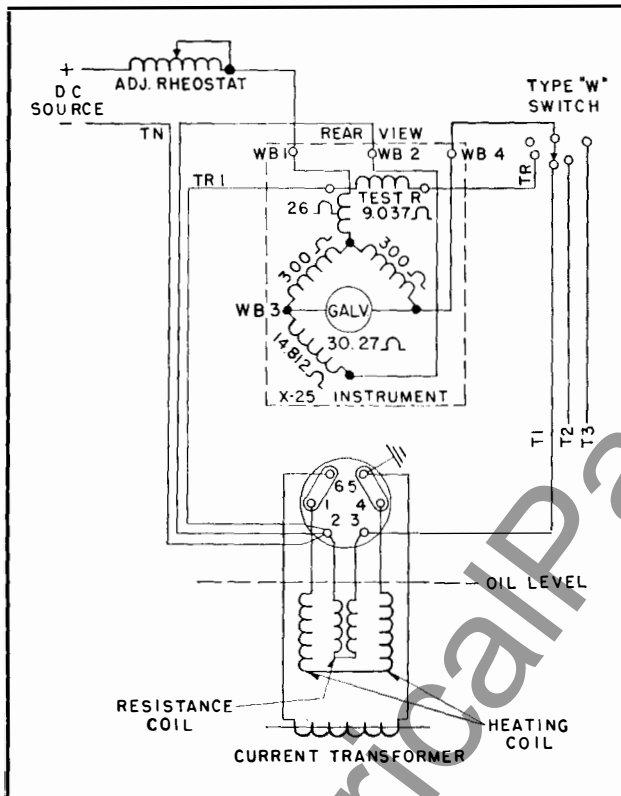

FIG. 1. Schematic Diagram of Connections.

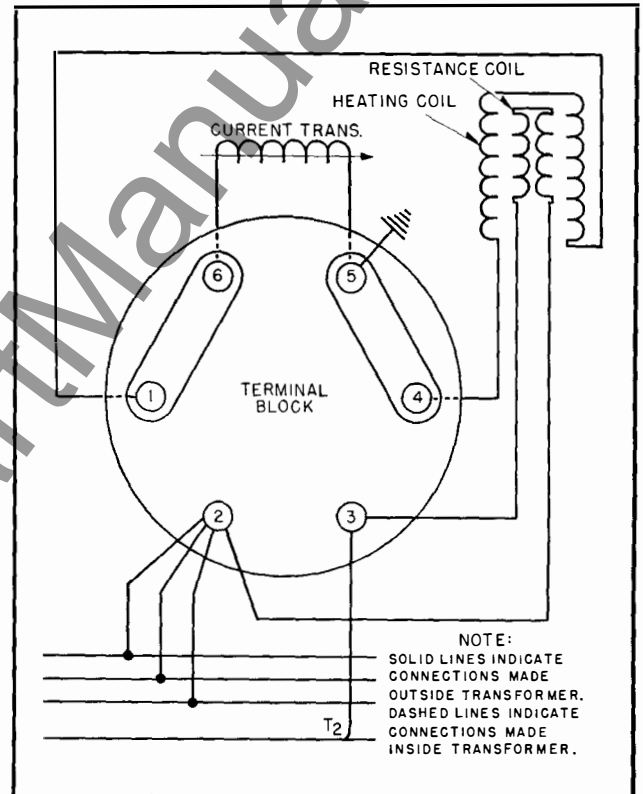

FIG. 2. Front and Rear Connections on Terminal Block.

THE BRIDGE TYPE HOTTEST SPOT TEMPERATURE INDICATOR for switchboard mounting consists of a specially designed galvanometer, a resistance bridge, one leg of which is embedded in a heating coil located in the top oil of the transformer, a current transformer, and an external terminal box. The heating coil is connected to the secondary of the current transformer.

During normal operation current flows in the heating coil section continuously so that the hottest spot temperature of the transformer winding may be found at any time by turning the Type W switch from off to the desired position. This hottest spot indicator is designed for short periods of indication, but may be safely used for continuous indication

providing the temperature indication is recognized as being 1° to 2°C high (the exact value may be determined by test). The added temperature rise is due to the continuous flow of current in the resistance coil and the resulting heating.

If desired, the temperatures of a number of transformers can be read on one instrument by using a multi-point switch at the switchboard. Fig. 1 shows a schematic diagram of the arrangement of the equipment for reading the temperature of one winding.

SHIPPING AND RECEIVING

The current transformer is usually shipped as part of the main transformer and is usually of the through type which is slipped over the lower end

TEMPERATURE INDICATOR

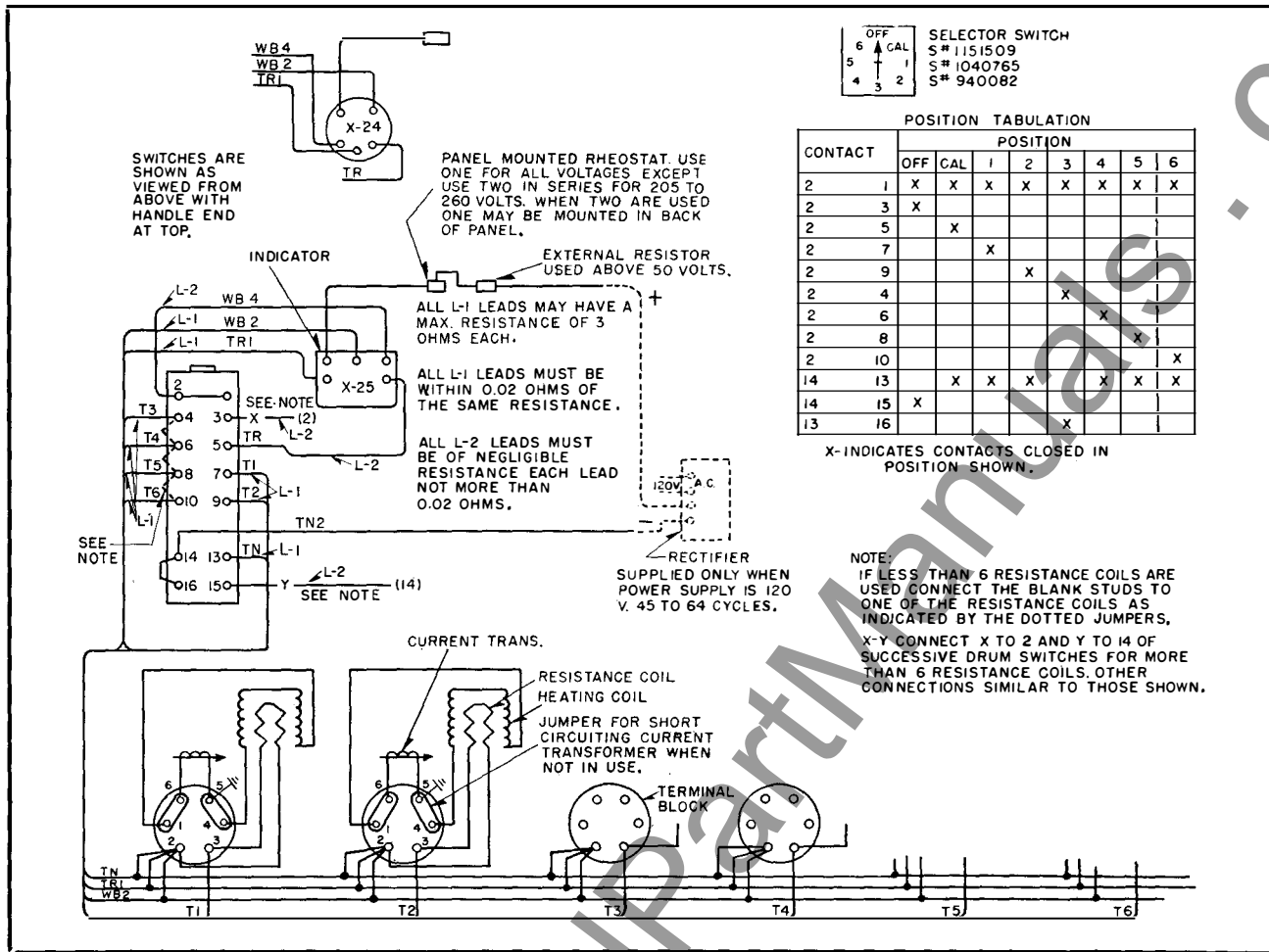

FIG. 3. Wiring Diagram for Temperature Indicator.

of the bushing and mounted on the under side of the cover. Sometimes it will be mounted on the top of the terminal board, bridges, or end frames. In this case, a Micarta tube will probably be used to conduct the current transformer leads to the terminal box. This tube will be installed in place on the current transformer. If the main transformer is not shipped in its tank, the tube is slid down or removed and tied to the current transformer.

The external terminal box will always be in place, and will be covered by a weatherproof conduit box. It may be a box as shown in Fig. 5 or a large box to take care of a number of leads including some not for the hot spot indicator. The heating coil and resistance element form an integral unit which is shipped in place whenever possible. If this cannot be done, it is shipped in a separate package marked "Details".

The fixed resistance coils are assembled in the indicator for mounting on the switchboard.

The drum switch and the rheostat are shipped in a separate package marked "Details". External resistors and/or rectifiers, if ordered, will also be found in this package.

INSTALLATION

A typical method of installing the hot spot indicator when it is shipped separately is outlined below. Always follow the instructions on the diagram, diagram nameplate and outline drawing for a particular installation.

1. Insert the heating coil with its embedded resistance through the proper hole in the wall and fasten securely in place. The location of the hole is shown on the outline drawing for the transformer.
2. Connect the two leads from the heating coil to the two studs marked 1 and 4 on the terminal block (on the inside of the transformer). See Fig. 5.
3. Connect the two leads from the current transformer to the two studs 5 and 6, on the ter-

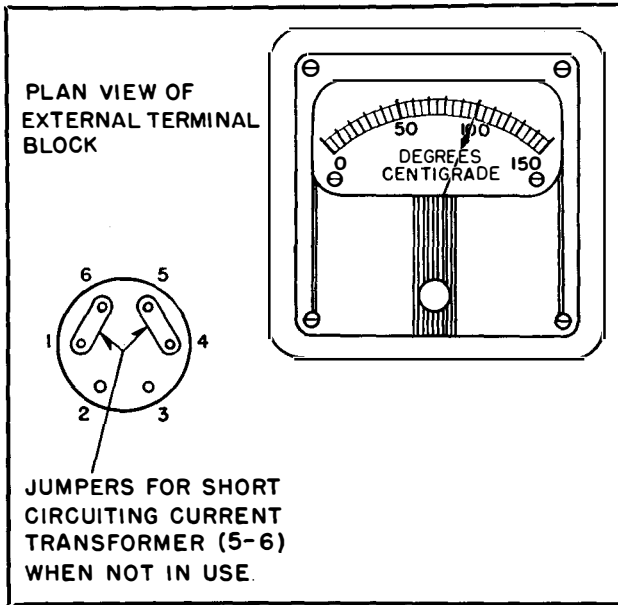

FIG. 4. Dial and Jumper for Short Circuiting Current Transformer When Not in Use.

former is tested, and these connections should not be changed.

4. If a bushing-type current transformer is used, it is usually shipped mounted in place under the cover around one of the bushings.

5. Using the weatherproof cable, connect the two leads from the resistance coil embedded in the well to the studs marked 2 and 3 on the outside of the external terminal block.

6. Mount the temperature indicator and resistance bridge on the switchboard and connect to the terminal box on the transformer as shown in Fig. 3 using 19-0226 (9700 C. M.) rubber-insulated weatherproof cable, or larger.

OPERATION

The current transformer is mounted inside the tank of the power transformer, usually on a bushing. Its primary winding carries the main current of one of the transformer windings and its secondary winding delivers to the heating coil a reduced current which is at all times proportional to the load current. The insulation of the current transformer serves to protect the heating coil and temperature indicating equipment from the high voltage of the main transformer windings.

terminal block (on the inside of the transformer). The leads are connected to the proper terminals of the current transformer at the factory when the trans-

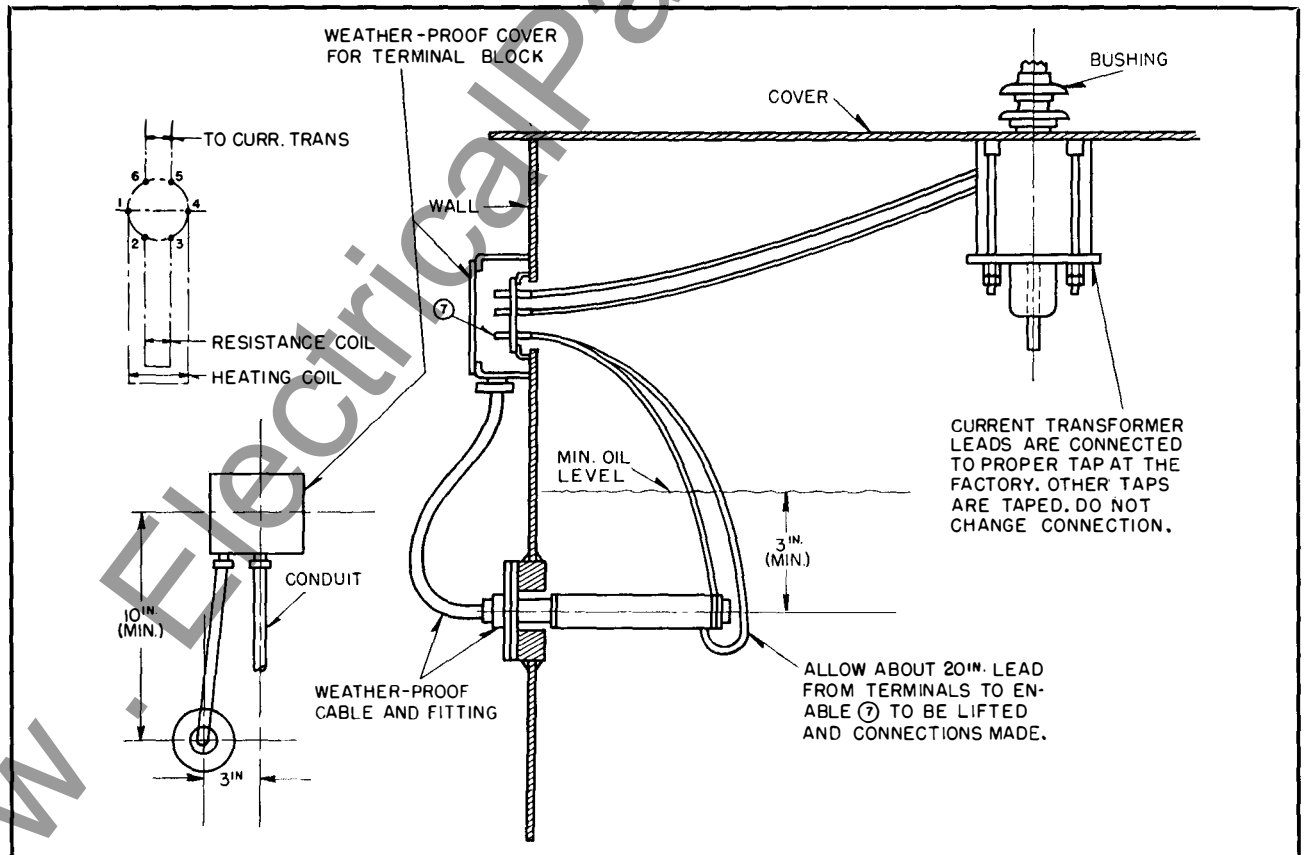

FIG. 5. Typical Installation with Bushing Current Transformer.

TEMPERATURE INDICATOR

The heating coil is placed in the hot top oil and its winding is worked at approximately the same current density as the main transformer. In addition, the thermal insulation of the heating coil is such that the elevation in temperature above oil is the same as that of the windings of the main transformer plus conventional 10°C hottest spot allowance under full load conditions. By these methods, the hottest spot temperature inside the transformer windings is duplicated at the resistance coil which is embedded inside the heating coil.

The resistance coil embedded in the well of the heating coil forms one arm of a Wheatstone Bridge, the other three arms being made up of fixed resistances. The values of these are so selected that with the embedded resistance at the temperature marked by the red line on the instrument dial, the bridge is balanced; that is, no current flows through the galvanometer when a direct-current voltage is applied between points WB1 and 2 (see Fig. 1). The instrument should therefore read this value when disconnected from the circuit. Any variation in the temperature of the embedded resistance changes its resistance thus causing an unbalance in the bridge and a current will flow through the galvanometer. There is a definite relation between this current and the temperature of the resistance coil making it possible to calibrate the galvanometer scale to read directly in degrees centigrade.

The instrument, which may be either indicating or a graphic recording type, is arranged for switch-board mounting.

The resistance coil in the tank element is usually separated from the fixed resistances of the bridge by long leads. Ordinarily, the d-c source for deflection of the galvanometer would be applied to WB1 and WB2, but because of the extension of bridge leg WB2-WB4 to 2-3, this voltage is applied at point 2 and through a series resistance at WB1.

This balances the leads and has the same net effect as the usual application of the d-c source in a Wheatstone Bridge.

It does not, however, correct for drop in current through the bridge due to the added resistance. This is accomplished by increasing the voltage applied to the bridge. The correct voltage to apply is determined by means of the Test Resistor and the adjusting rheostat. The test resistor has a fixed resistance of 9.037 ohms which is the resistance the resistance coil would have at 0°C.

Connecting the test resistor across the open leg of the bridge would cause the instrument to indicate 0°C provided the voltage was right and there was no unbalance due to lead resistance. The lead resistances are balanced out by connecting one end of the test resistor to point 2 by lead 2-TR1 having the same resistance as 2-WB2. The voltage is then increased by adjusting the rheostat until the instrument indicates 0°C. The bridge has now been calibrated and temperature measurements may be made by connecting the embedded resistance coils into the circuit one at a time by means of a drum switch as shown in Fig. 3. The Type W selector switch provides overlapping contacts up through terminal No. 10, thus preventing the possibility of overloading the galvanometer when changing positions.

Occasional inspection is necessary to make certain the connections are tight and that the indicator is operating.

RENEWAL PARTS

Order renewal parts from the nearest Westinghouse Office. Include a complete description of the part wanted along with the data on the nameplate attached to the transformer tank wall.



WESTINGHOUSE ELECTRIC CORPORATION
SHARON PLANT • TRANSFORMER DIVISION • SHARON, PA.

Printed in U.S.A.



RECEIVING • INSTALLATION • OPERATION INSTRUCTIONS

TEMPERATURE INDICATOR Hottest Spot Resistance Bridge Type Wall Mounted Switchboard Indicating

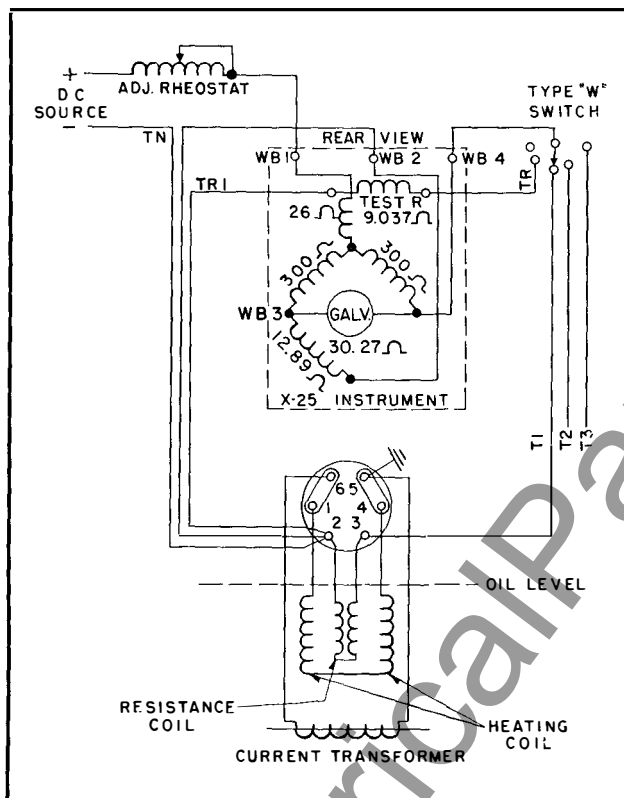

FIG. 1. Schematic Diagram of Connections.

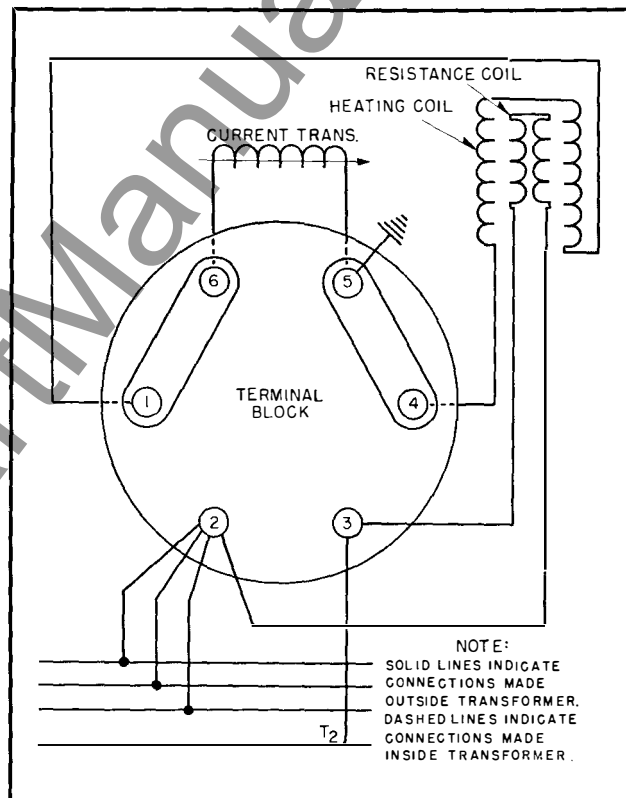

FIG. 2. Front and Rear Connections on Terminal Block.

THE BRIDGE TYPE HOTTEST SPOT TEMPERATURE INDICATOR for switchboard mounting consists of a specially designed galvanometer, a resistance bridge, one leg of which is embedded in a heating coil located in the top oil of the transformer, a current transformer, and an external terminal box. The heating coil is connected to the secondary of the current transformer.

During normal operation current flows in the heating coil section continuously so that the hottest spot temperature of the transformer winding may be found at any time by turning the Type W switch from off to the desired position. This hottest spot indicator is designed for short periods of indication, but may be safely used for continuous indication

providing the temperature indication is recognized as being 1° to 2°C high (the exact value may be determined by test). The added temperature rise is due to the continuous flow of current in the resistance coil and the resulting heating.

If desired, the temperatures of a number of transformers can be read on one instrument by using a multi-point switch at the switchboard. Fig. 1 shows a schematic diagram of the arrangement of the equipment for reading the temperature of one winding.

SHIPPING AND RECEIVING

The current transformer is usually shipped as part of the main transformer and is usually of the through type which is slipped over the lower end

TEMPERATURE INDICATOR

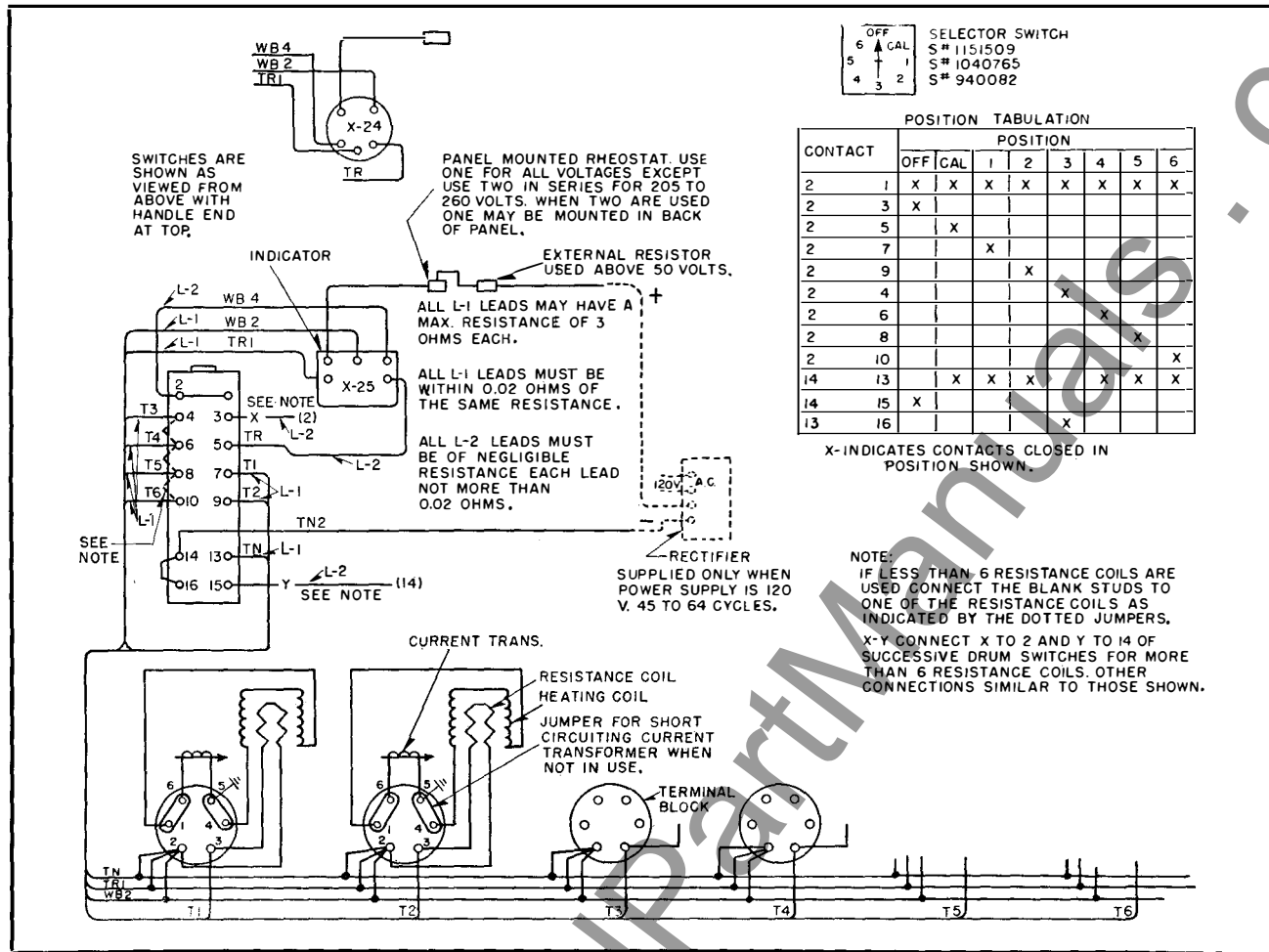

FIG. 3. Wiring Diagram for Temperature Indicator.

of the bushing and mounted on the under side of the cover. Sometimes it will be mounted on the top of the terminal board, bridges, or end frames. In this case, a Micarta tube will probably be used to conduct the current transformer leads to the terminal box. This tube will be installed in place on the current transformer. If the main transformer is not shipped in its tank, the tube is slid down or removed and tied to the current transformer.

The external terminal box will always be in place, and will be covered by a weatherproof conduit box. It may be a box as shown in Fig. 5 or a large box to take care of a number of leads including some not for the hot spot indicator. The heating coil and resistance element form an integral unit which is shipped in place whenever possible. If this cannot be done, it is shipped in a separate package marked "Details".

The fixed resistance coils are assembled in the indicator for mounting on the switchboard.

The drum switch and the rheostat are shipped in a separate package marked "Details". External resistors and/or rectifiers, if ordered, will also be found in this package.

INSTALLATION

A typical method of installing the hot spot indicator when it is shipped separately is outlined below. Always follow the instructions on the diagram, diagram nameplate and outline drawing for a particular installation.

1. Insert the heating coil with its embedded resistance through the proper hole in the wall and fasten securely in place. The location of the hole is shown on the outline drawing for the transformer.

2. Connect the two leads from the heating coil to the two studs marked 1 and 4 on the terminal block (on the inside of the transformer). See Fig. 5.

3. Connect the two leads from the current transformer to the two studs 5 and 6, on the ter-

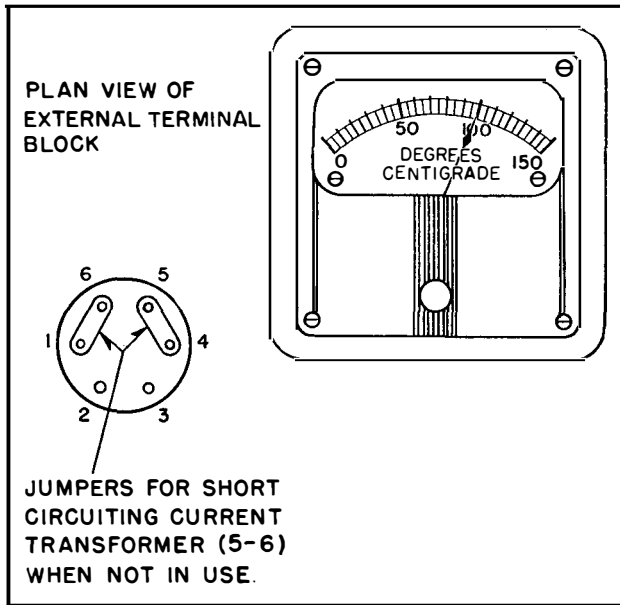

FIG. 4. Dial and Jumper for Short Circuiting Current Transformer When Not in Use.

terminal block (on the inside of the transformer). The leads are connected to the proper terminals of the current transformer at the factory when the trans-

former is tested, and these connections should not be changed.

4. If a bushing-type current transformer is used, it is usually shipped mounted in place under the cover around one of the bushings.

5. Using the weatherproof cable, connect the two leads from the resistance coil embedded in the well to the studs marked 2 and 3 on the outside of the external terminal block.

6. Mount the temperature indicator and resistance bridge on the switchboard and connect to the terminal box on the transformer as shown in Fig. 3 using 19-0226 (9700 C. M.) rubber-insulated weatherproof cable, or larger.

OPERATION

The current transformer is mounted inside the tank of the power transformer, usually on a bushing. Its primary winding carries the main current of one of the transformer windings and its secondary winding delivers to the heating coil a reduced current which is at all times proportional to the load current. The insulation of the current transformer serves to protect the heating coil and temperature indicating equipment from the high voltage of the main transformer windings.

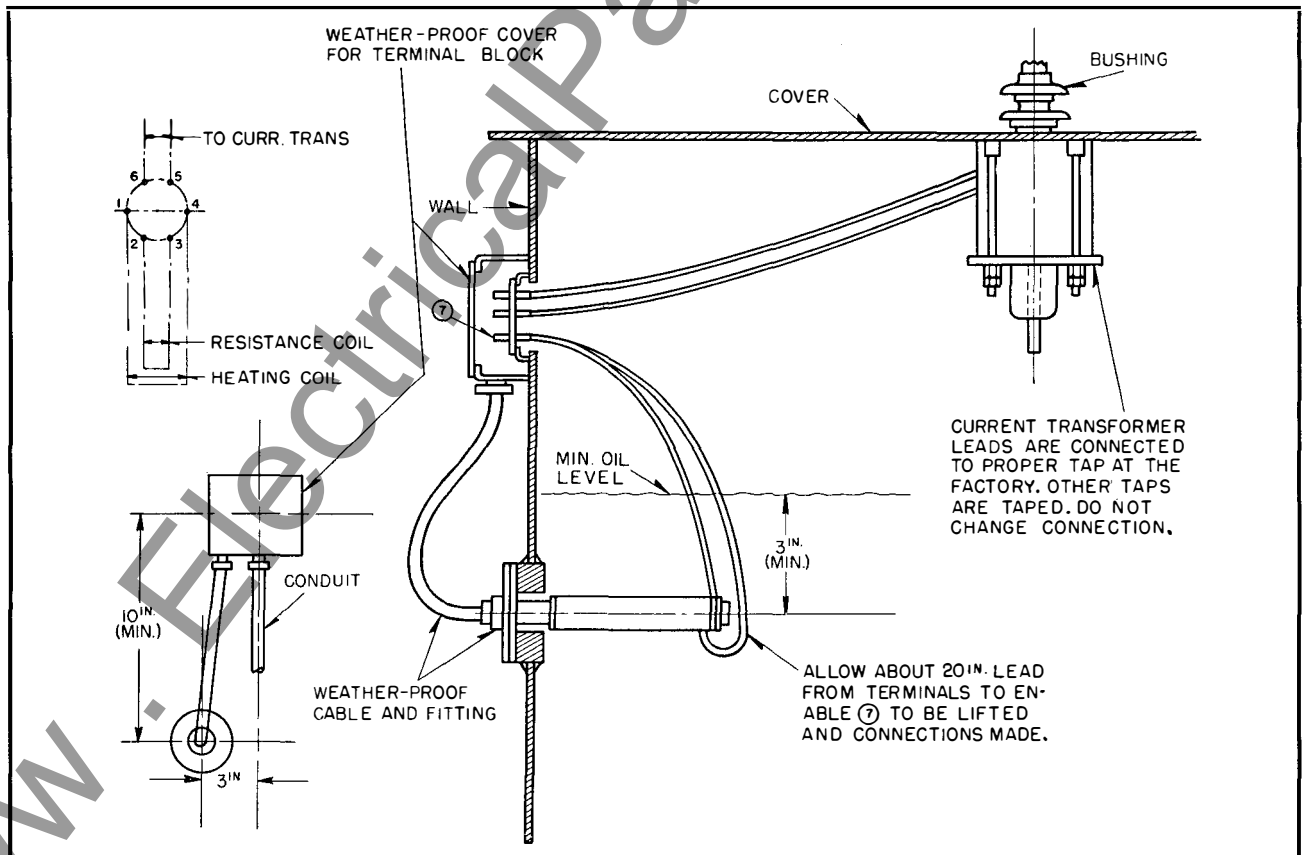

FIG. 5. Typical Installation with Bushing Current Transformer.

TEMPERATURE INDICATOR

The heating coil is placed in the hot top oil and its winding is worked at approximately the same current density as the main transformer. In addition, the thermal insulation of the heating coil is such that the elevation in temperature above oil is the same as that of the windings of the main transformer plus conventional 10°C hottest spot allowance under full load conditions. By these methods, the hottest spot temperature inside the transformer windings is duplicated at the resistance coil which is embedded inside the heating coil.

The resistance coil embedded in the well of the heating coil forms one arm of a Wheatstone Bridge, the other three arms being made up of fixed resistances. The values of these are so selected that with the embedded resistance at the temperature marked by the red line on the instrument dial, the bridge is balanced; that is, no current flows through the galvanometer when a direct-current voltage is applied between points WB1 and 2 (see Fig. 1). The instrument should therefore read this value when disconnected from the circuit. Any variation in the temperature of the embedded resistance changes its resistance thus causing an unbalance in the bridge and a current will flow through the galvanometer. There is a definite relation between this current and the temperature of the resistance coil making it possible to calibrate the galvanometer scale to read directly in degrees centigrade.

The instrument, which may be either indicating or a graphic recording type, is arranged for switch-board mounting.

The resistance coil in the tank element is usually separated from the fixed resistances of the bridge by long leads. Ordinarily, the d-c source for deflection of the galvanometer would be applied to WB1 and WB2, but because of the extension of bridge leg WB2-WB4 to 2-3, this voltage is applied at point 2 and through a series resistance at WB1.

This balances the leads and has the same net effect as the usual application of the d-c source in a Wheatstone Bridge.

It does not, however, correct for drop in current through the bridge due to the added resistance. This is accomplished by increasing the voltage applied to the bridge. The correct voltage to apply is determined by means of the Test Resistor and the adjusting rheostat. The test resistor has a fixed resistance of 9.037 ohms which is the resistance the resistance coil would have at 0°C.

Connecting the test resistor across the open leg of the bridge would cause the instrument to indicate 0°C provided the voltage was right and there was no unbalance due to lead resistance. The lead resistances are balanced out by connecting one end of the test resistor to point 2 by lead 2-TR1 having the same resistance as 2-WB2. The voltage is then increased by adjusting the rheostat until the instrument indicates 0°C. The bridge has now been calibrated and temperature measurements may be made by connecting the embedded resistance coils into the circuit one at a time by means of a drum switch as shown in Fig. 3. The Type W selector switch provides overlapping contacts up through terminal No. 10, thus preventing the possibility of overloading the galvanometer when changing positions.

Occasional inspection is necessary to make certain the connections are tight and that the indicator is operating.

RENEWAL PARTS

Order renewal parts from the nearest Westinghouse Office. Include a complete description of the part wanted along with the data on the nameplate attached to the transformer tank wall.



WESTINGHOUSE ELECTRIC CORPORATION
SHARON PLANT • TRANSFORMER DIVISION • SHARON, PA.

(Rep. 1-58) Printed in U.S.A.