

Instructions for No Load Tap Changer Type WSS



I.L. 48-064-6A

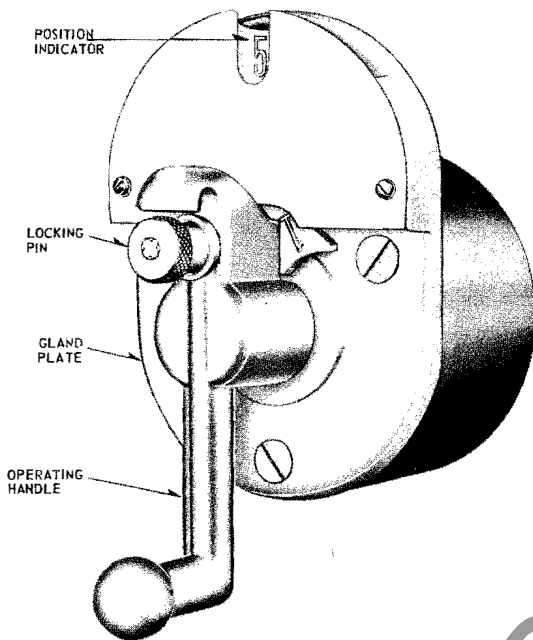

Fig. 1 Operating Mechanism Position Indicator

The Type WSS Tap Changer provides an adequate and convenient method for changing transformer tap connections from outside the transformer case. The tap changer is mounted under oil in the transformer case and is intended for operation only when the transformer is disconnected from the line.

IMPORTANT. No-load tap changers must not be operated with the transformer energized; the transformer must not be energized unless the tap changer is locked on an operating position (see transformer nameplate).

The Type WSS tap changers are made in a variety of arrangements for 3 phase, 15 KV and 34.5 KV, 150 ampere requirements. The 34.5 KV tap changer is slightly larger physically than the 15 KV tap changer and incorporates in some designs an extension of the stationary channel to facilitate the location of the operating shaft. The drive shaft may extend from either side and the tap leads may be connected from either side. When less than three phases or five

positions are required, the unused contacts are omitted from the assembly and a stop provided on the external operating mechanism. The stationary contacts, with provision on one end for connecting the leads, are through type studs mounted in a thermoset plastic channel and are arranged in a straight line parallel to the motion of the moving contacts. Good connections are assured by silver plated wiping contacts and by high pressure indentation of the stud onto the tap leads. The free end of the stationary contacts are crimped to prevent their removal. See Figure 2.

INSTALLATION

Tap changers are usually shipped mounted on the core and coil assembly and connected to the external operating mechanism. Hence, when shipment of the core and coil assembly is made separately from the tank and fittings, it is necessary to make the connection of the tap changer drive shaft to the external operating mechanism on assembly in the field.

Before pinning the shaft, when installing a new tap changer, it is essential that the position indicated by the external position indicator agree with the actual position of the tap changer contacts. See Figures 1 and 3 for relationship between tap changer position and position number of external mechanism. The location of Number 1 position depends from which side the tap changer is driven.

Match marks are provided near the pinion bearing to aid in setting the tap changer "ON" position. The moving contact is in the center of the "ON" position zone when the match mark on the pinion shaft lines up with the match mark on the stationary channel.

The external operating mechanism is connected to the tap changer drive shaft through a shaft and slip joint. This slip

www . ElectricalPartManuals . com

Westinghouse Electric Corporation
Power Transformer Division, Sharon, Pa.

Printed in U.S.A. (T.P.)



DESCRIPTION • OPERATION • MAINTENANCE
INSTRUCTIONS

**CVR-1 CONTROL FOR TYPES URS, URT, AND URH
 TAP CHANGERS**

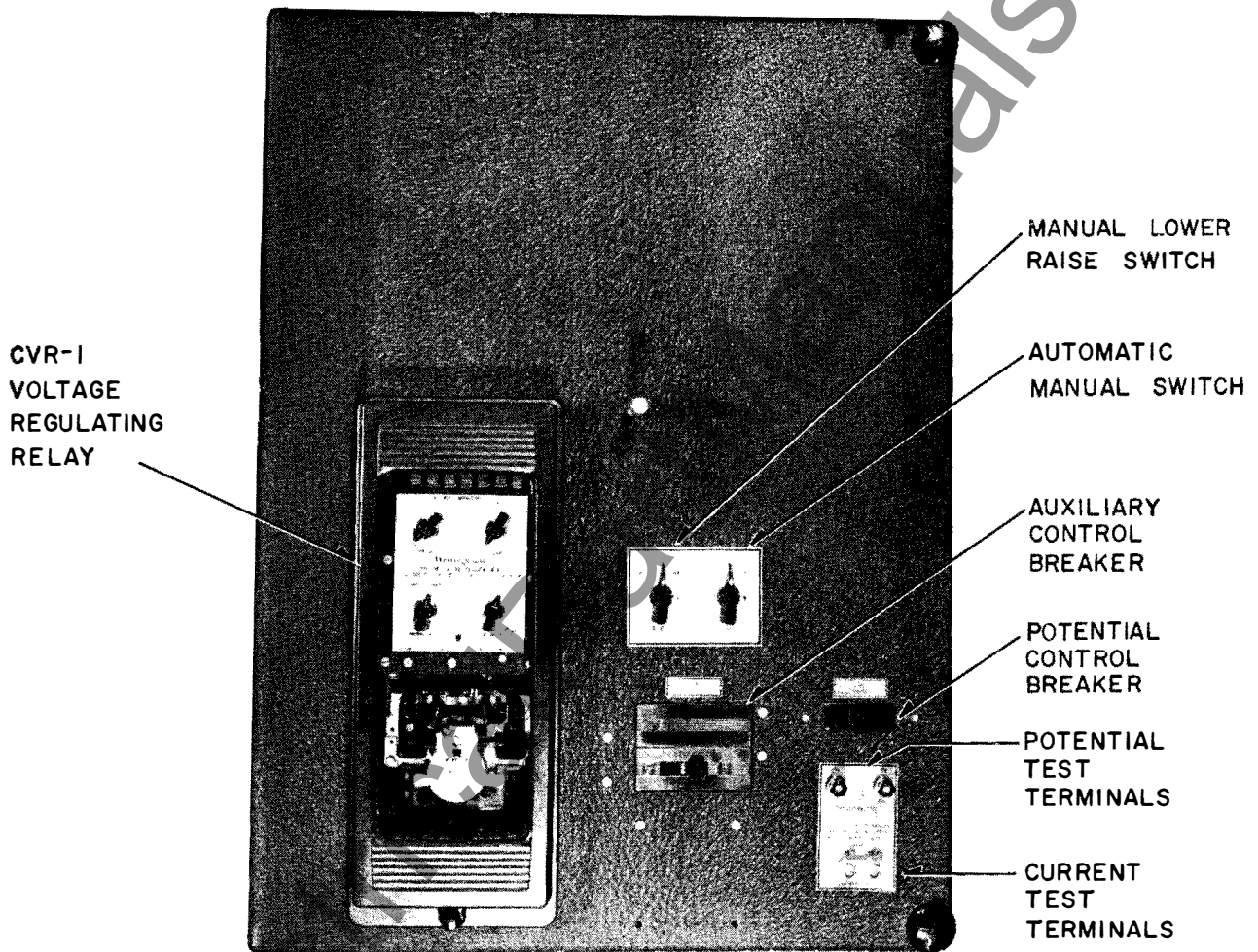

Figure 1 - Automatic Control Panel

Control equipment for Load Tap Changers used for power regulators and power transformers is designed for automatic operation of the tap changer with provisions for manual control during emergency operation or during testing. The wiring and schematic diagrams should be referred to for any particular installation. A study of the following instructions, however, will be found helpful in understanding the operation of the actual circuit diagram furnished with the unit.

DESCRIPTION

A typical automatic control panel is shown in Figure 1. The panel consists of a CVR-1 Inverse Time Voltage Regulating Relay, Automa-

tic-Off-Manual switch, Manual Lower-Raise Switch, two Control Circuit Breakers, and a set of Potential and Current Test Terminals.

The panel is of steel and is contained either in a steel cabinet mounted separately on the side of the transformer or in an air compartment forming an integral part of the tap changer tank. A hinged mounting is used so that the rear of the panel is readily accessible for inspection and maintenance. The CVR-1 Relay is of the Flexitest case construction for semi-flush mounting. The Flexitest case construction allows the relay to be easily disassembled from the case for inspection, testing, adjusting and remounting.

The automatic control panel connects through control wiring to the mechanically operated auxiliary and limit cam switches which are a part of the tap changer. These cam switches are geared directly to the tap changer motor and are contained in an air compartment within the tap changer housing.

FUNCTION

In general, the control system of a load tap changer to be completely adequate must perform five distinct functions:

1. Initiate the operation of the tap changer motor to cause a tap change.
2. Provide means for insuring that once a tap change is initiated it will be carried through to completion.
3. Prevent the tap changer mechanism from running past the limit positions.
4. Indicate tap position, number of operations, etc.
5. Protect the source of auxiliary power and the potential transformer in case of short circuit.

In the following description of control circuit operation, the equipment which performs the above functions is described and its operation outlined.

Figure 2 is the schematic control circuit diagram for the CVR-1 Relay and associated panel equipment of Figure 1. Other typical diagrams depict the control as it is applied to the various load tap changers as follows: Figure 3-URS, Figure 4-URT, Figure 5-URH.

Control components are as follows:

PT1 and PT2 are potential test terminals for measuring regulated voltage. CT1 and CT2 are current test terminals to which an ammeter may be connected to read output current.

AB1 "Potential Circuit" breaker, AB2 "Auxiliary Circuit" breaker and AB3 "Motor Circuit" breaker are De-ion type circuit breakers for overload protection of the control circuit and for its isolation from source on short-circuit or for test.

ACT is an auxiliary current transformer ratio 5 to .2 amperes, for use with the line drop compensator.

AM A - AM M is the Automatic-Manual Switch and is a three position switch for selecting automatic, off, or manual operation of the tap changer.

MCR-MCL is the Manual Control Switch and is a momentary-contact, normally off, double-throw switch for manually initiating raise or lower operation of the tap changer.

PP is the sensing element of the CVR-1 Voltage Regulating Relay for automatically initiating raise or lower operation of the tap changer in response to the load center voltage. AR, AL, 120X, and 120Y are all part of the type CVR-1 as interposing and piloting relays between the operation of the sensing element and the tap changer. The CVR-1 description, operation, and setting are described in detail in I.B. 47-065-9.

120, LR, CLR, 124, LL, CLL, 125, SN7 and SN8 are all cam operated switches mechanically driven by the tap changer drive. Their sequences are shown in the various sequence charts beginning with Figure 3.

R and L are the motor control relays. These are Type N control relays described in I.L. 11192. The two relays are electrically interlocked by contacts R1 and L1 of Figure 3 and R5 and L5 of Figures 4 and 5.

BC and its associated resistors and capacitors, shown in Figure 3, is the DynAC brake used on the Type URS tap changer and described in detail in I.L. 47-064-3.

MB, shown in Figures 4 and 5, is the Type AK magnetically operated brake used on the Type URT and URH tap changers and described in I.L. 47-064-4.

SS is the handcrank interlock safety switch. The specific constructions for the URS, URT, and URH tap changers are described in the respective tap changer instruction books. In all cases, SS is open when the handcrank is engaged.

IS and NE, shown in Figure 3 only, are the mechanical stop interlock switch and indicator used on the URS tap changer to open the motor circuit if the mechanical stop is operated. On the URT and URH tap changers, this function is performed by LL, LR, 124, and 125.

DL is a light for illumination of the control or operating mechanism compartment.

ES is a convenience outlet.

The heater is for use as required by atmospheric conditions to prevent condensation of moisture in the control and operating mechanism compartments.

The DL, ES and heater circuits are protected by fuse FU, independent of the circuit breakers, so that these devices may be used even when the control may be out of service for repair or maintenance.

MANUAL CONTROL OPERATION

Manual operation of the tap changer is obtained by setting the AMA-AMM switch on its "MAN" position and operating the MCR-MCL switch to its "RAISE" or "LOWER" position to operate the tap changer toward position 16R or 16L, respectively.

The operation is as follows: With AB1, AB2, AB3, SS and IS closed and the automatic-manual switch set on "MAN", closing contacts MCR by operating the manual control switch to "RAISE" energizes AR in Figure 2, which closes its contacts (AR1 in Figures 3, 4, and 5) to energize motor contactor R. This, in turn, closes contacts (R3 in Figure 3 or R2, R3, and R4 in Figures 4 and 5) to start the motor and operate the tap changer in the raise direction. Contact AR5 in Figure 2 closes to set up the sealing circuit on AR, which is completed by the closing of 120X contact as soon as the tap changer mechanism moves a small amount and which remains sealed until cam switch 120 opens at the completion of the tap change. The sealing circuit is first completed through AR2, AL3, and the normally-closed 120Y relay contact of Figure 2, thus by-passing MCR. As the tap changer proceeds in the raise direction, cam switch 120 in Figures 3-4 or 120R in Figure 5 closes to pick up relays 120X and 120Y. The seal is retained by the circuit through AR5 and 120X until 120X opens at the completion of the tap change.

In the special case of the URS tap changer, Figure 3, the closing of 120 also operates the DynAC brake BC, as described in I. L. 47-064-3. When 120 or 120R opens at the completion of the tap change and MCR has been opened, AR is de-energized and drops out, allowing R to drop out and stopping the tap changer. If MCR is held closed, R is held in and the tap changer immediately makes another operation.

For operation in the lower direction, the manual control switch is placed on the "LOWER" position, closing MCL and energizing AL, which sets up the circuits in a similar

fashion to operate the tap changer in the lower direction.

Limit switches CLR and CLL in Figure 2 and LR, LL, 124, and 125 in Figures 4 and 5 open mechanically at the limit positions to prevent overtravel of the tap changer in either direction.

TRANSITION ZONE

On both the URT and URH tap changers, a transition zone exists between positions 1L and N equivalent in traveling time to several step changes. Cam switch SN8 in Figure 4, which is closed only during the neutral transition period of the URT tap changer, assures completion of a tap change through this zone once it has started. When going in the "RAISE" direction, this circuit is completed through SN8, R1, and L5 to the R contactor. In the "LOWER" direction, the seal is made through SN8 and R5 to the L contactor.

Neutral transition on the URH tap changer is accomplished through the blocking action of the cam switch SN7, seen in Figure 5. SN7 is open during the neutral transition period and prevents the energizing of 120X coil until just before the end of the neutral zone is reached. When going in the "RAISE" direction, the seal on AR is completed in Figure 2 through 120Y, AL3, AR2, and CLR. In the "LOWER" direction, the seal on AL is completed through 120Y, AL2, AR3, and CLL.

AUTOMATIC CONTROL OPERATION

Automatic operation of the tap changer is obtained by setting the AMA-AMM switch on its "AUTO" position. The tap changer is then controlled by the CVR-1 voltage regulating relay.

The operation is as follows: With AB1, AB2, AB3, SS, and IS closed and the automatic-manual switch set on "AUTO", the CVR-1 relay will close contacts PR or PL as operation in the raise or lower direction, respectively, is required to maintain the load center voltage within the set band limits. The line drop compensator, represented by the X and R elements in Figure 2, will compensate for line drop between the regulator unit and the load center.

If the voltage across the sensing element PP falls below the setting of the left hand contact long enough for the disk operated PR con-

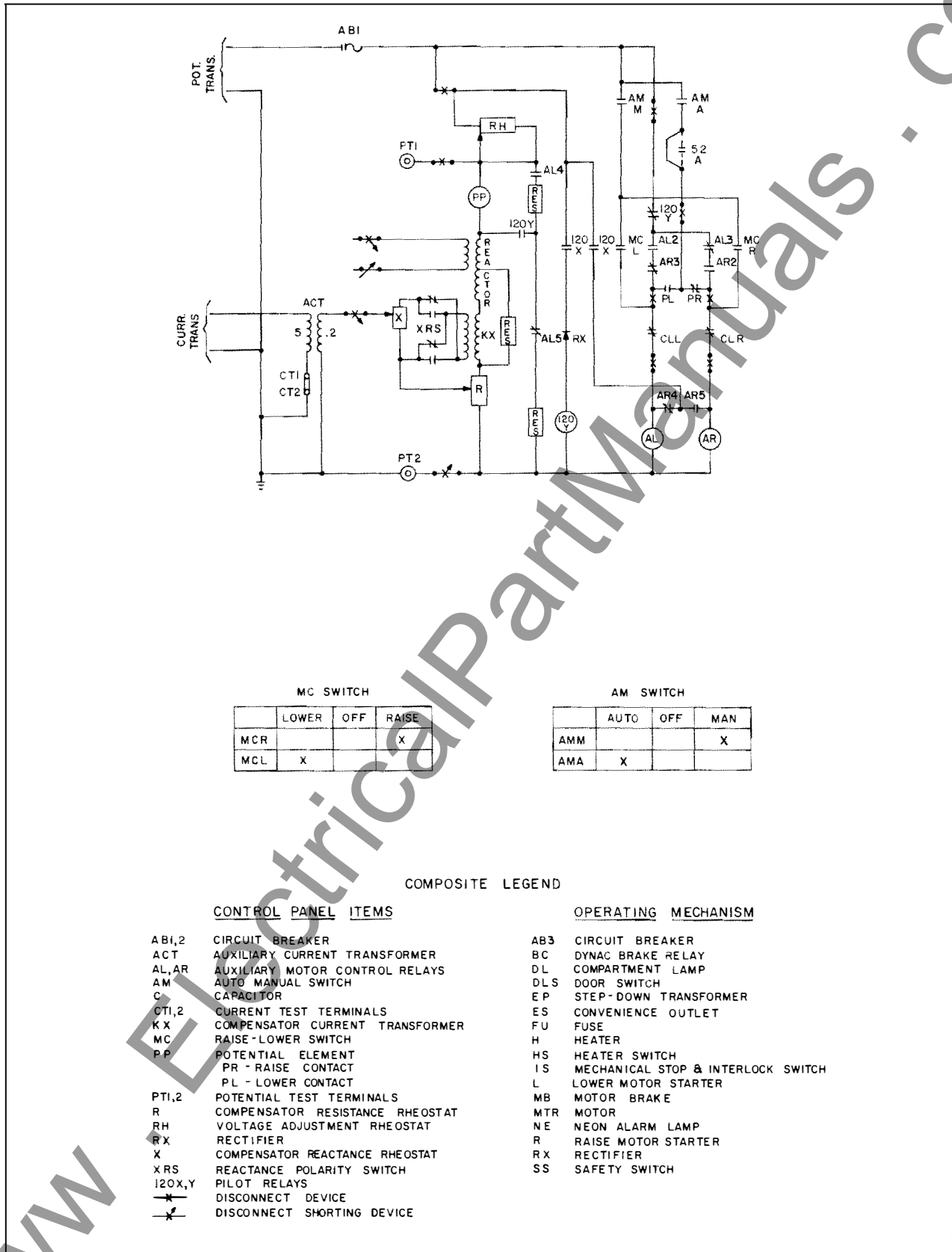

Figure 2 - CVR-1 Voltage Regulating Relay Control Diagram

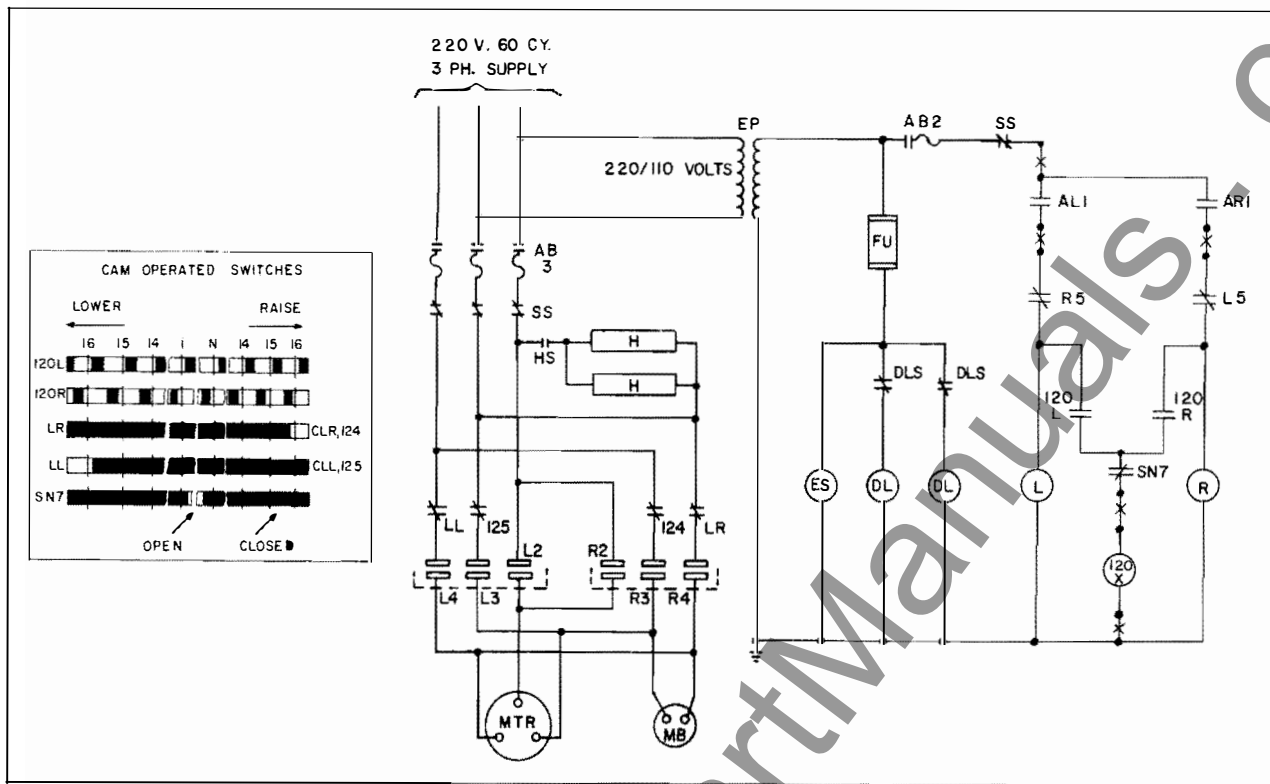

Figure 5 - URH Tap Changer Control Diagram

tact to close, the relay AR is energized and seals itself in through the normally closed 120Y relay contact. Closing the AR relay motor contact (AR1 in Figures 3, 4, and 5) operates the tap changer through motor starter R to raise the voltage exactly as under MANUAL CONTROL OPERATION. As soon as the tap changer mechanism has moved a small amount, the 120 switch in the URS and URT cam mechanism (or the 120R in the URH mechanism) closes to energize the 120X relay (see Figures 3, 4, and 5) which in turn takes over the sealing of the AR relay through contact AR5 and operates the 120Y slug delayed relay. The normally open 120Y relay contact closes and with contact AL5 shunts the reactor with a 3,000 ohm resistor which increases the current through the voltage coil PP, tending to rotate the disc to open contact PR. Thus, for small voltage deviations there will be a short delay between successive tap changer operations. After the tap changer arcing contact has closed on position, the 120 pilot switch opens, allowing the 120X relay to release the AR relay. The tap changer motor is stopped by the motor brake exactly as under MANUAL CONTROL OPERATION. If the voltage is not corrected,

the sequence is repeated until the voltage is corrected or a tap changer limit position is reached.

A rise in voltage to close the right hand contact PL would initiate a similar sequence of operations to lower the voltage. In the latter instance the closing of AL4 and the 120Y normally-open contact will place a shunt through another 3000 ohm resistor around the potential coil PP, producing a torque that tends to rotate the disk to open contact PL.

Cam switch SN7, which is open during the neutral transition stage of the URT and URH tap changer, blocks periodic completion of a circuit through cam switch 120 to the 120X relay, which would otherwise cause too much counter-torque during this period.

The amount of time delay that precedes the initial operation of the tap changer in response to a change of voltage depends upon a combination of these four factors:

1. The position of the moving disk contact of the CVR-1 relay prior to the voltage change.
2. The limiting voltage (bandwidth) setting of the CVR-1 relay.

3. The magnitude of the voltage change.
4. The damping factor of the CVR-1 relay.

Only the bandwidth and the damping factor settings are within the control of the operator.

If the potential supply should fail during automatic tap changer operation, all relays and the tap changer motor would be de-energized, bringing the tap changer to a stop between positions. When power is restored after such a failure, the AR relay coil in Figure 2 is initially energized by the PR contact of the CVR-1 relay (which is closed under a no-voltage condition). Sealing of the AR relay is initially accomplished through the normally-closed 120Y contact and later through the 120X circuit just as in any normal "RAISE" operation. After the tap changer moves to the next higher position, further voltage regulation can take place in the usual manner.

The action of braking, limit cams, and progress through the neutral transition zones is accomplished exactly as described under MANUAL CONTROL OPERATION.

The setting and operation of the CVR-1 relay is described in detail in I. B. 47-065-9.

INSTALLATION

All parts used in the construction of the tap changer control are assembled, adjusted and tested at the factory as a unit, therefore, no adjustments are necessary.

Crank the tap changer over its entire range by hand in order to make sure the mechanism is not binding at any point.

Open the potential and auxiliary transformer sources at the AB control breakers and set the automatic manual switch on Manual. Consult the wiring diagram supplied with the unit and connect an external source of power at the required voltage to the control circuit side of the breakers.

CAUTION: The control breakers must be in the OPEN position, otherwise the external source voltage may feed back into the main transformer causing a high voltage to develop across the line bushings and overload the potential-auxiliary transformers. Also, the ground side of the potential test source must be connected to terminal PT2.

Manually operate the tap changer by closing the momentary Manual Control switch to Lower or Raise. The tap changer should operate. Operate the unit over the entire range from raise to lower to be sure all cam switches are operating in their proper sequence.

Before attempting a check on automatic control, make a temporary setting of the CVR-1 relay band limits by means of the scale which is calibrated in volts. Refer to I. B. 47-065-9 for detailed instructions on setting the bandwidth, or for a more precise method of checking the performance.

With the resistance and reactance compensator dials each set on zero, apply a voltage on the control side of the AB1 breaker which is greater than the highest band limit setting. Place the automatic-manual switch on AUTO. After the PL contact closes the tap changer should run in the lower direction. Then cut in resistance on the test rheostat (RH in Figure 2) by moving the rheostat knob in a clockwise direction until the PR contact closes to run the tap changer in the raise direction. Note that the voltage must be held for the initial time delay period before the tap changer will operate in either direction. Before attempting final calibration the relay should be energized at 120 volts for an hour.

Return the test rheostat to OFF, remove the test voltages, energize the unit, and then close the AB control breakers.

Refer to instruction book 47-065-9 for settings of the line drop compensator, being certain the polarity switch is in the correct position.

www.ElectricalArtManuals.com



WESTINGHOUSE ELECTRIC CORPORATION
SHARON PLANT • TRANSFORMER DIVISION • SHARON, PA.

Printed in U.S.A

Instructions for Type URT Load Tap Changer, 15 KV and 34.5 KV Ratings



I.L. 48-064-12

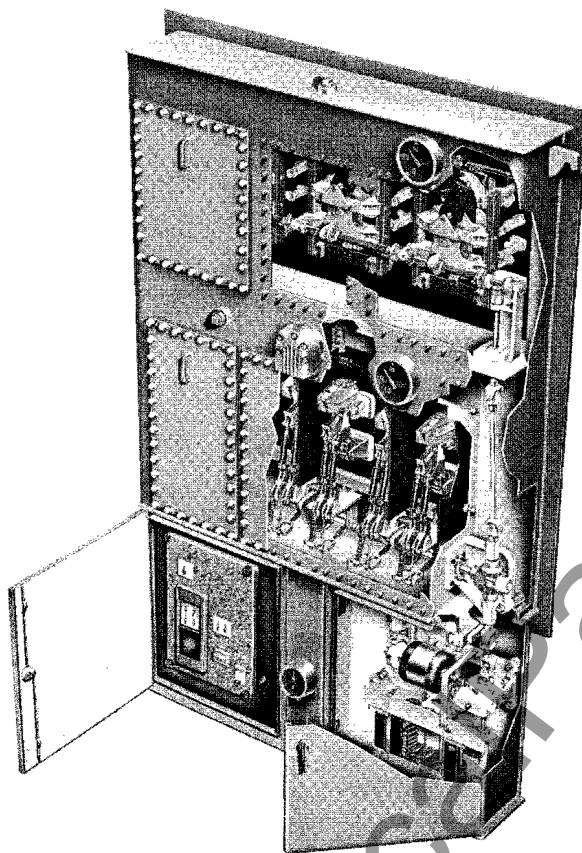

Fig. 1 "URT" Tap Changer

THE TYPE URT TAPCHANGER, Fig. 1, is used to change transformer taps under load to control voltage or phase angle. It utilizes selector switches for selecting the proper tap on the transformer and combination spring loaded, direct drive transfer switches for interruption of the current so that the selector switches are not called upon to interrupt any of the circuits.

Electrical connections are varied to suit particular applications. Therefore, the transformer instruction plate should be consulted for the connection of a given installation.

To fulfill its function of controlling volt-

age magnitude, the URT tap changer employs the following mechanisms: (1) reversing switches, which select the polarity of the tapped winding section, (2) selector switches, which connect to the proper tap from the winding, and (3) transfer switches, which perform the arcing duty of switching operations. NOTE: On some units the reversing switch is omitted to meet customer requirements.

The selector switches and reversing switches are located in an oil filled compartment at the top of the tap changer house. The transfer switches are located below the selector switches in a separate oil filled compartment which is sealed against in-breathing but which permits out-breathing through a two-stage vent and relief device.

The operating mechanism is located in an air compartment included as part of the tap changer and consists of the motor, gearing and shafting for operating the tap changer together with the cam switches and the auxiliary gearing to operate them.

Provision is made for hand cranking the unit by attaching a hub directly on the motor shaft. The hand crank also serves to operate a safety switch in the motor and control circuits. To indicate tap changer position, both an external indicator and an internal indicator are supplied.

RECEIVING

The type URT tap changer is normally shipped attached to the transformer and should be considered ready to operate. The vent and relief device for the transfer switch is normally removed for shipment and shipped detail. This item and other items shown on the outline drawing as having been removed for shipment should be installed prior to placing the unit in service.

STORING

In the event the tap changer is to be stored for an extended period of time, before putting in storage it is recommended that the selector switch and transfer switch compartments be filled with oil. The operating mechanism compartment should be properly protected against moisture and the space heater therein connected and energized.

INSTALLATION

The type URT tap changer is usually shipped mounted on the transformer. Before placing in service, the housings should be filled with oil to the proper level as indicated on the tap changer liquid level indicators.

CAUTION: Vent each compartment by removing the pipe plugs from the filling holes, prior to pumping oil into the tap changer.

Remove all blocking from contactors or relays, and, if control equipment is not integral with the transformer, it should be installed and wired according to the diagram furnished with the unit. The tap changer should be operated by hand over its entire range in both directions to be sure no binding has been introduced.

The vent and relief device for the transfer switch compartment is shipped detail and must be mounted before the tap changer is operated under load. With the transfer switch oil gauge indicating normal oil level or below, the blind flange over the relief device mounting (for shipping only) may be removed without lowering the oil level. This is true even though the relief device and the oil gauge are on the same horizontal centerline. Check transformer outline for information regarding quantity of oil required. It is recommended that the oil filled compartments be filled by attaching a hose to the drain valves and forcing oil into these compartments through a filter press. These compartments must be vented at the time of filling to prevent any unnecessary stress on the tank due to the oil pressure.

Following filling with oil and after a reasonable period of time has passed to permit the air bubbles in the oil to rise, at least three oil samples should be taken from each compartment and tested. The unit should not be energized if the load tap changer compartment oils test less than 22 KV. If it is required to draw a vacuum on the transformer tank portion of the unit, it is recommended that both tap changer compartments have a connection made to the main tank so as to equalize pressures on the insulating panels. If the rated test strength of the tap changer tank as given on the small nameplate inside the operating mechanism door is less than that of the main transformer tank, a valve and vacuum gauge should be used so the rated value is not exceeded.

CAUTION: When installing units with 3 phase motors be sure that proper phase rotation is applied to unit before operating to limit position. With unit on Position "N" energize the tap changer by the raise-lower switch and note the direction of operation as indicated by the switch. If the tap changer does not operate in proper direction interchange two motor power leads.

PRINCIPLES OF OPERATION

The URT tap changer is operated by a motor which drives through reduction gearing to open and close the transfer and selector switches in proper sequence. When moving from one position to the next the main blade of the transfer switch opens first. After the main blade opens, the arcing contact which is in parallel with the main blade is toggled open by a spring accelerated mechanism. This operation is followed by the movement of the proper selector switch moving finger contact from one stationary contact to the next. The sequence of operation of the transfer switch is then reversed; the arcing contact closes then toggles in, and then the main blade closes. Necessary cams on the control switch assembly have sealed in the motor contactors that carry the operation through to completion.

INSPECTION, MAINTENANCE AND ADJUSTMENT

Since warranties expire after one year, it is recommended that the entire tap changer be thoroughly inspected at the end of its first year of service, and that the frequency of subsequent inspections be based on the facts found at this inspection. Complete inspection of the contacts and the operating mechanism should be made at least every fifth year. During inspection, check the fastening of all three shunts on each transfer switch. Maintenance of the transfer switch contacts depends to a great extent on the current they carry. Replacement is recommended when contact erosion has reduced the arcing material to 1/16 inch thickness at any point on the surface of either the moving or stationary contact.

LUBRICATION

Bearings and gears in the air compartment require occasional lubrication with anti-corrosive lubricant. Lubriplate #630-A is recommended for gears and non-sliding surfaces. All bearings in the main tap changer housing are oil-immersed. The speed reducer should be refilled after draining, using a good 10-W-30 oil.

OTHER HELPFUL DATA

Proper compression of the Buna-N packing material on the drive shafts is obtained when the packing gland springs are compressed to 7/8 inch.

The mechanical stop operates approximately four handcrank turns past the end position. The adjusting screws in the operating arm do not give fine adjustment of the operation point, but are to allow for manufacturing variations so that the stop fork clears the lug on the gear at the two-turn point and definitely intercepts it at four turns.

The springs on the selector switch moving contacts and transfer switch main blade stationary contacts should be compressed to 7/8 inch over the cup washers when

switches are in closed position.

The reducer requires approximately 1-1/3 quarts of 10-W-30 oil.

Bolts holding the transfer switch arcing contact shunt should be well tightened and secured by safety wire through the heads.

OVERHAUL AND REPAIR

In general the only maintenance required on the URT tap changer is replacement of the arcing contacts and the adjustment of the brake. A supplemental leaflet is provided covering the adjustment of the brake.

REPLACEMENT OF ARCING CONTACTS

To replace the moving arcing contacts proceed as follows:

1. Open transfer switch.
2. Remove retaining ring and flat washer from one end of 3/8 inch diameter moving arc tip shaft. See Fig. 3.
3. With switch open pull on moving arc tip to partially compress the arc tip spring. This will relieve the pressure on the arc tip shaft and permit the shaft to be removed. With the shaft out, ease the arcing contact forward until the arc tip spring and dashpot can be removed.
4. Unbolt the arc tip shunt from the arc tip frame.
5. Replace moving arcing contact in reverse manner.

To replace the stationary arcing contacts the procedure is as follows:

1. Remove the two arc chamber mounting bolts and pivot the front of the arc chamber upward. See Fig. 3.
2. Unbolt both the main and auxiliary arcing contacts.
3. Replace both the main and auxiliary

com

BUFFER SPRING
ADJUSTMENT NUT

ARC TIP FRAME
BUFFER SPRING

ARC TIP
ADJUSTMENT NUTS

ARC TIP INSULATING LINK

MAIN BLADE INSULATING LINK

MAIN BLADE BELL CRANK

ARC TIP BELL CRANK

MAIN BLADE CONNECTING LINK

ARC TIP CONNECTING LINK

MAIN BLADE CONNECTING
LINK ADJUSTMENT NUTS

ARC TIP CONNECTING
LINK PIVOT BLOCK

CAM FOLLOWER ARM

LOWER BUFFER SPRING

DRIVING CAM

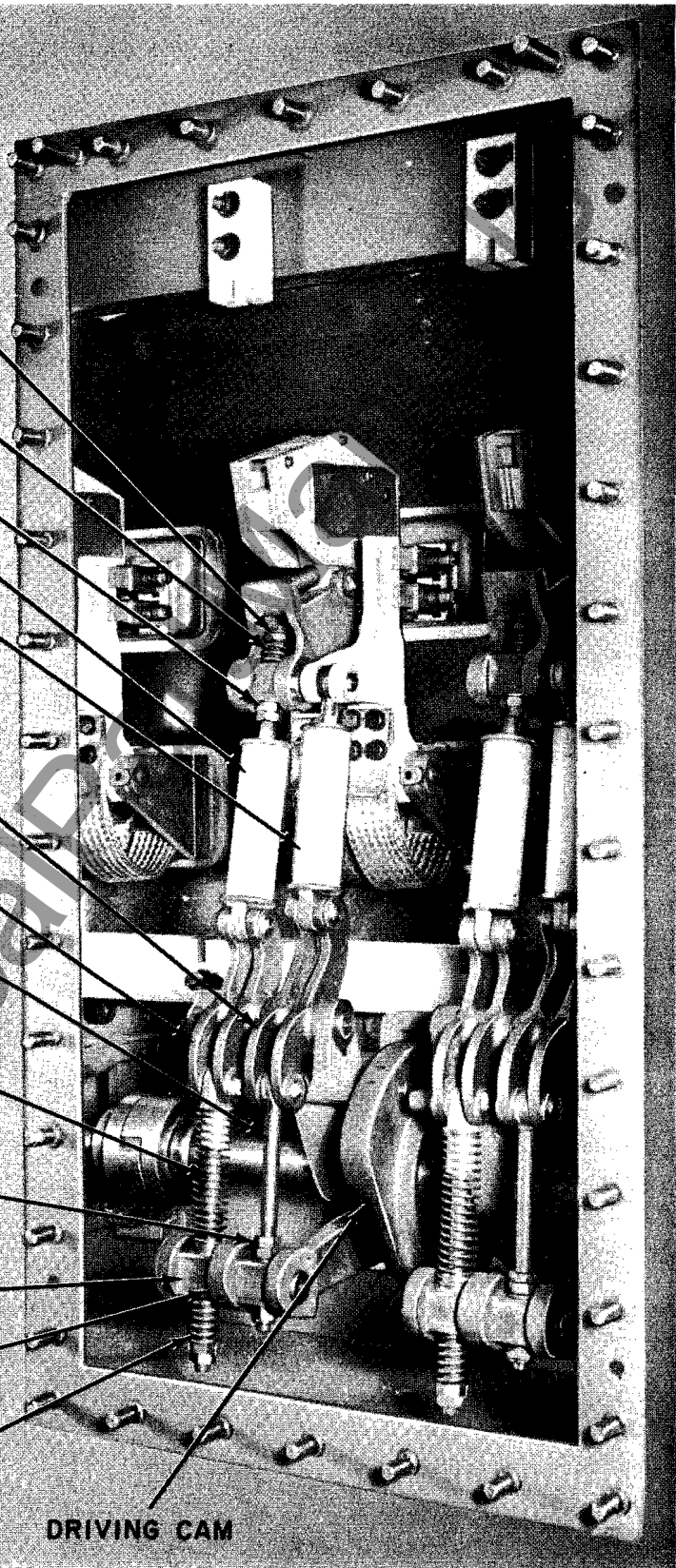

Fig. 2 "URT" Tap Changer Transfer Switch

WWW.Electrical.com

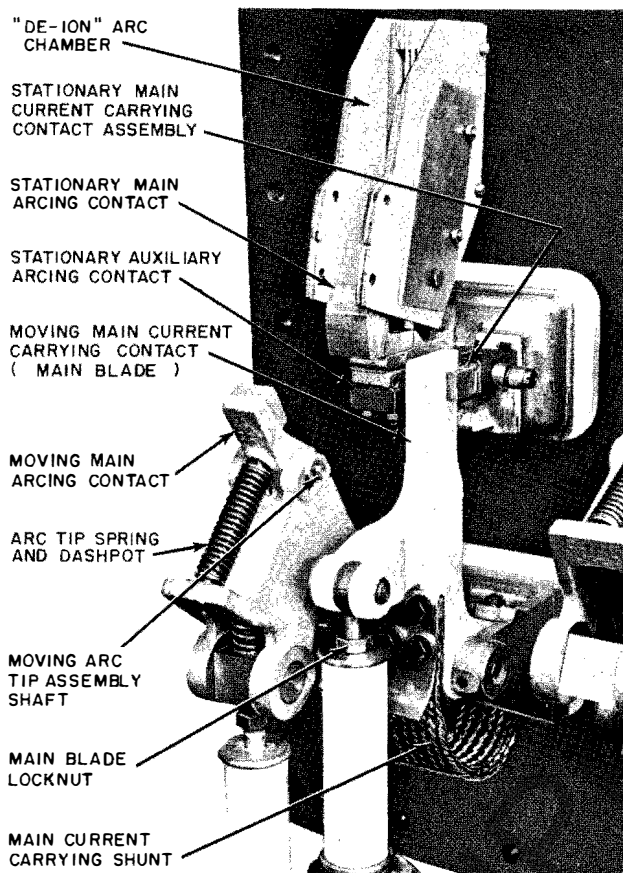

Fig. 3 "URT" Tap Changer Transfer Switch

contacts. Before tightening the main stationary contact align stationary contact with the moving arcing contact. Approximately 1/8 inch clearance should exist between edge of moving contact and inside of arc box.

4. Pivot arc chamber downward into position and replace mounting bolts.

After contact replacement check transfer switch adjustments as follows:

TIMING

Proper timing of a URT necessitates coordinating the selector switches, the transfer switches and the cam switch assembly. For factory assembly purposes the non-operating position N_3 is used to coordinate the above components. Therefore, it is

strongly recommended that position N_3 be used for any timing check made on the URT tap changer.

Position N_3 is the actual mechanical neutral of the tap changer mechanism. To arrive at position N_3 from position "N" the unit must be cranked in a lower direction through two non-operating positions for a 33 position tap changer and through one non-operating position for a 17 position unit. For a 33 position tap changer the double-lobed 120 cam will rotate 360 degrees while progressing from position N to N_3 . For a 17 position tap changer the single-lobed 120 cam will also rotate 360 degrees. Check the internal dial plate on the cam switch assembly plus the 120 cam to determine when N_3 has been reached.

The following conditions occur simultaneously on position N_3 of a properly timed URT tap changer.

1. The internal dial plate indicates position N_3 . Note that the external indicator hand is in the blank zone between 1L and N.

2. The cam switch assembly is positioned so that the 120 cam switch roller is on the center of the 120 cam lobe.

3. On the cam switch assembly the arm of the geneva pinion is on a line through the hub of the pinion and the hub of the geneva gear but 180 degrees from direct engagement with the geneva gear.

4. The moving selector contacts are both vertically upward and connected to stationary contact R. See Fig. 4 and Sequence Chart Fig. 5.

5. The reversing switch moving contact connects to stationary contact "A" which is on the right as viewed through the inspection door. The moving contact is on entering side.

6. All transfer switches are closed.

7. The match marks on the transfer switch cam hub are matched (in line) with

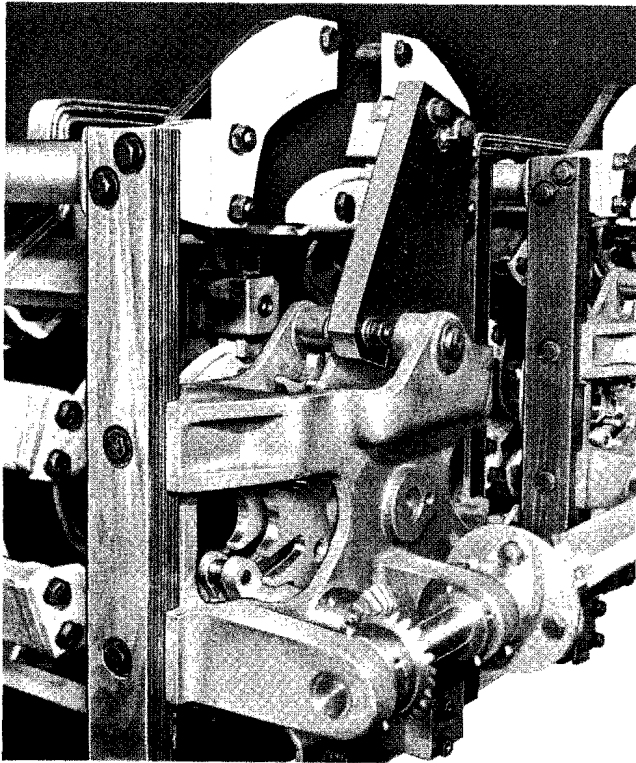

Fig. 4 "URT" Tap Changer Selector Switch

similar match marks on the stationary bearing supports for the cam. The left lobe is up.

On some special units, a single neutral, rather than the standard five position neutral, is provided. This single point N coincides with the N_3 described above.

For non-reversing units, N_3 is two positions beyond the end position. To check the timing on these units it will be necessary to remove the retaining ring from the shaft holding the U-shaped mechanical stop adjacent to the stop gear mounted on the input shaft of the speed reducer. With the unit de-energized and inspection covers removed, hand crank the mechanism, with the stop U removed to position N_3 described above. N_3 will be shown on the cam switch assembly indicator ring. After completion of the checking procedure, crank the unit back into its normal operating range and re-install the stop U and retaining ring prior to refilling the unit and energization.

A few units are built where it is necessary for the "reversing switch" to function as a coarse selector rather than reversing so as to match impedance characteristics or other special requirements. On these units, identifiable by reference to the diagram nameplate, both moving selector contacts are on the first stationary contact to the left (viewed from the door) of the top (12 o'clock) contact, when on N_3 . See Point 4 above. Reversing switch is to the right, on contact "A". The transfer switch cam has its match marks lined up and has the right lobe up. See Point 7 above.

In addition to the above checks also hand crank the tap changer at least two positions in one direction and while cranking note which selector and transfer switches open and close. Refer to Sequence Chart Fig. 5. The E transfer switch is the switch on the left in each phase as viewed through the inspection door. It is in series with the inner selector moving contact, the inner moving contact being defined as the finger closer to the Micarta panel. During the time the "E" transfer switch is open, the inner moving contact on the selector should move from one stationary contact to the next. Likewise while the "F" transfer switch is open, the outer moving selector contact should move from one contact to the next. This hand crank check serves to verify the foregoing conditions.

CAUTION: All adjustments should be made with normal pressure within the transformer.

ADJUSTMENTS

No adjustments are required on the selector and reversing switches once the unit has been properly assembled and timed.

Transfer switch adjustments are relatively few. If proper adjustments are made when installing new arcing contacts those adjustments, under normal conditions, will be sufficient for the life of the contacts.

Complete readjustment of a transfer switch may be accomplished as described

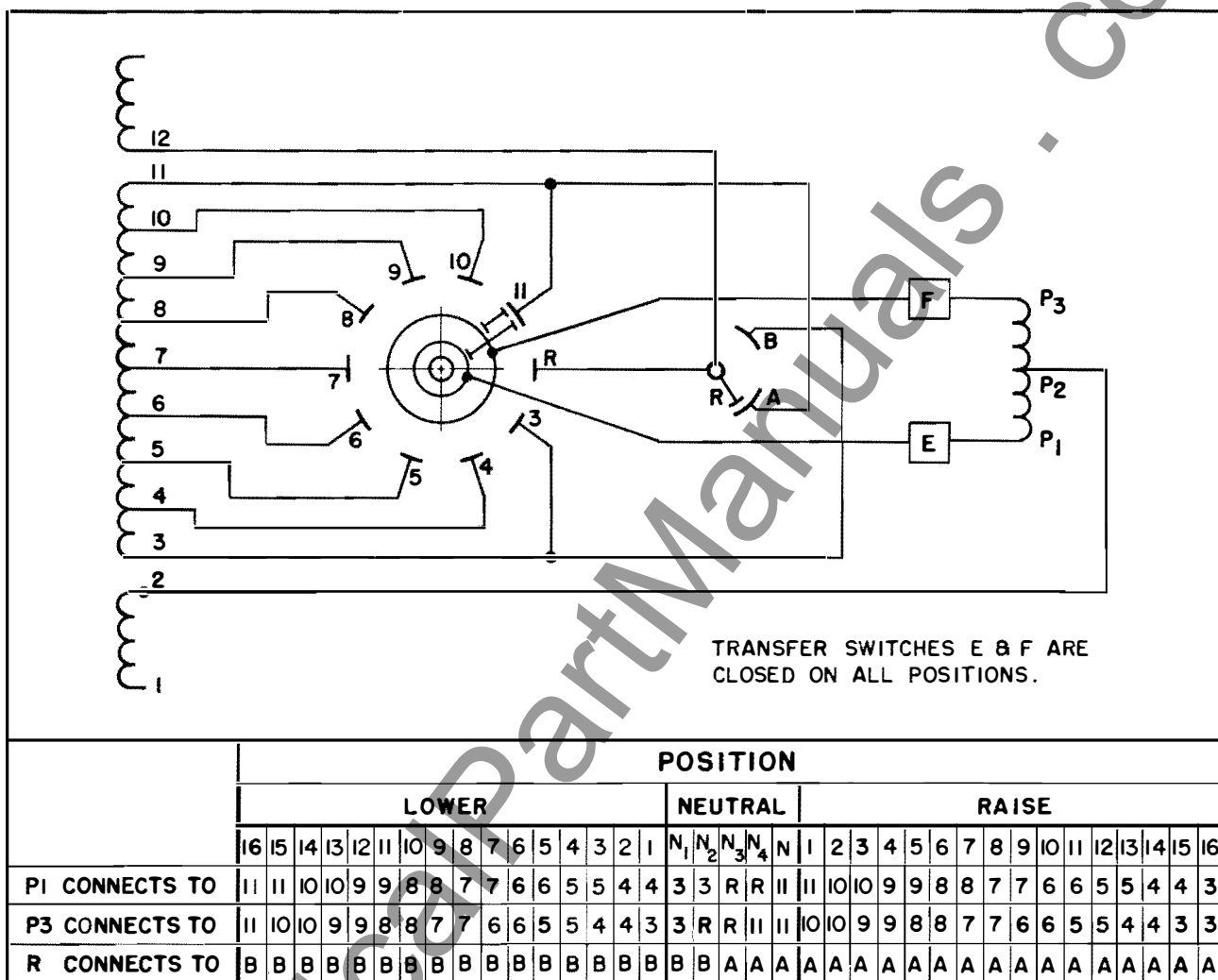

TRANSFER SWITCHES E & F ARE CLOSED ON ALL POSITIONS.

Fig. 5 Typical "URT" Tap Changer Schematic Connection Diagram (One Phase) with Sequence Chart

below. This description pertains to the relationships within one transfer switch and is not to imply that all three "E" or "F" switches on a three phase unit are operating exactly together. A tolerance of 1/2 of a hand crank turn on the motor shaft is allowed for all three switches to toggle closed or open.

1. Open transfer switch and disconnect both insulating links from the bell cranks.
2. Crank mechanism until unit is ON POSITION (Note 120 cam).
3. With unit on position the cam follower arm shown in Fig. 2 will be at its

lowest point of travel. Adjust the arc tip connecting link adjustment nuts until the overall lower buffer spring length is between 1-3/8 and 1-1/2 inches. In general, start with the 1-1/2 inch dimension.

4. Crank mechanism until main drive cam rotates 90 degrees. This will raise the cam follower arm to its highest point of travel. Adjust main blade connecting link adjustment nuts until leading edge of bell crank is approximately 1/8 inch from main base casting. (clearance only)

5. Connect arcing member insulating link to its associated bell crank. Leave main blade link disconnected from bell crank.

6. Turn lower arc tip adjustment nuts toward insulating links as far as threads permit.

7. Close switch.

8. Adjust arc tip adjustment nuts upward against block until there is only 1/8 inch clearance between moving arc tip assembly shaft (3/8 dia. shaft) and back of slot in arc tip frame. This 1/8 inch clearance can conveniently be obtained by advancing the arc tip adjustment nuts slowly until the shaft can just be detected going solid in back of the slot. At this point, using the outside diameter of the washer on the shaft as a guide, scribe a mark on the arc tip frame behind the slot. Then lower the arc tip adjustment nuts until the distance from the scribe mark to the outside diameter of the washer is 1/8 inch. However the dimension must be checked with switch completely closed.

9. Adjust buffer spring adjustment nut until the upper buffer spring is compressed to approximately a 7/8 inch dimension. This adjustment is most easily made when the switch is nearly closed.

10. Close the main blade by hand until the leading edge of the main blade is approximately 1/8 inch from the edge of the magnetic yoke around the bridging contacts. With the main blade remaining in this position adjust the main blade insulating link by releasing the locknut and turning the link until the hole in the lower end matches the holes in the bell crank. Connect the insulating link and bell crank. Tighten the main blade locknut against the insulating link.

11. Open the switch completely. Slowly crank the switch toward the closed position. At the instant the auxiliary arcing contact "makes" (the main arcing contact having already "made") the leading edge of the main blade should be a minimum of 1/8 inch from the stationary contacts. If under the 1/8 dimension refer to paragraph 3 and readjust lower buffer spring toward 1-3/8 inch dimension as required. This will advance the closing of the arcing member with respect to the main blade. (On double finger,

higher current units, measurement is made to upper finger.)

12. Crank the switch to the closed position. With the switch closed, the tension spring on the stationary current carrying contacts should be adjusted to a dimension (including cup washers) of 7/8 inch. This should give a normal contact pressure of 11-1/2 to 12-1/2 pounds.

The foregoing adjustments and checks should give proper transfer switch operation.

CAUTION: After any adjustments be sure all lock nuts are tight and all retaining rings are properly seated.

A special wrench is needed to hold one of the adjustment nuts while the second nut is locked against it. This special wrench is furnished with the tap changer and is hung on the brace immediately inside and to the left of the right phase transfer switch inspection door.

CAUTION: Pumping and filtering of oil under certain circumstances may cause electrical charges to be built up in the oil to such an extent that electrical breakdown of the gas above the oil is possible. When a filter press is used to filter the oil in the load tap changer housing, precautionary measures should be taken to prevent an explosion caused by the possible static discharge of the electrical charge which could be built up in the housing. If this electrical discharge takes place in an explosive gas mixture, the result could be a damaging explosion.

A thorough purging with nitrogen of the accumulated gases formed in the load tap changer housing should be made before filtering the oil. This will offset any possible reaction between the static discharge and the accumulated gases.

If for any reason it is found necessary to use the same oil which has been drained from the tap changer, the following precautions must be taken:

1. Be sure the drums used for oil storage are absolutely clean and dry. Inspection

of the drums will save much grief.

2. Be sure the oil is filtered before it is returned to the tap changer compartment.

3. The oil should be relatively clear of free carbon before it is considered satisfactory.

4. After filling the tap changer compartment with oil and before energizing the unit, test at least three representative samples in the standard test cup. The test value should be 26 KV or better.

5. The tap changer should never be energized when the oil in the housing tests less than 22 KV in the standard test cup.

CAUTION: The transfer switch compartment is equipped with a pressure relief valve to permit exhausting of gases formed by the interruption of the switching arc in oil. When repainting, care should be exercised that the relief valve be masked or removed to prevent paint clogging the exhaust screen. This screen should be given periodic inspections (at approximately six-month intervals) for clogging by paint or other foreign materials. After painting, be sure the masking is removed and the screen is clear.

SPARE PARTS

Only a minimum of spare parts is required for type URT tap changers, but it is recommended that a complete set of moving contact assemblies and stationary contact assemblies for the arcing member of the transfer switch and one set of transfer switch shunts be kept in stock for replacement, if necessary.

If the purchaser desires a more complete stock, the following parts are recommended:

One motor.

Motor relays as required.

One set of cover plate gaskets.

One set of transfer switch main current carrying contacts.

RENEWAL PARTS

If renewal parts are required, order from the nearest Westinghouse Sales Office, giving description of parts wanted, with transformer serial number and rating as stamped on transformer instruction plate.

Westinghouse Electric Corporation

Power Transformer Division, Sharon, Pa.

www.ElectricalPartManuals.com



INSTALLATION • OPERATION • MAINTENANCE INSTRUCTIONS

NO LOAD TAP CHANGER TYPE WSB-4

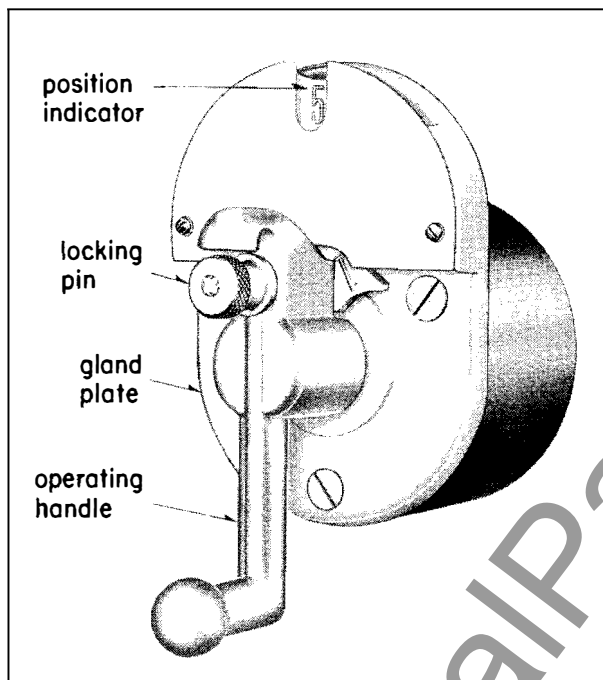

FIG. 1. Operating Mechanism and Position Indicator

THE TYPE WSB-4 TAP CHANGER provides an adequate and convenient method for changing transformer tap connections from outside the transformer case. The tap changer is mounted under oil in the transformer case and is intended for operation only when the transformer is disconnected from the line.

IMPORTANT. No-load tap changers must not be operated with the transformer energized; the transformer must not be energized unless the tap changer is locked on an operating position (see transformer nameplate).

The Type WSB-4 Tap Changers are made in a variety of sizes and arrangements to meet voltage and current requirements. When more than one tap changer deck is operated from a single mechanism, the individual decks are mounted axially with a polyester glass shaft passing through each deck. The stationary contacts, with provision on the opposite end for connecting the

leads, are through type studs mounted in a thermoset plastic base, and are arranged on a radius equal to that of the moving contacts. Good connections are assured by silver plated wiping contact surfaces, and by either high pressure indentation or swaging of the stud on to the tap leads. See Fig. 2.

INSTALLATION

Tap changers are usually shipped mounted on the core and coil assembly and connected to the external operating mechanism. Hence, when shipment of the core and coil assembly is made separately from the tank and fittings, it is necessary to make the connection of the tap changer drive shaft to the external operating mechanism on assembly in the field.

Before pinning the shaft, when installing a new tap changer, it is essential that the position indicated by the external position indicator agree with the actual position of the tap changer contacts. See Figs. 1 and 5.

The position of the contacts is indicated on the internal operating mechanism. A match mark on the Geneva gear bracket lines up with the position number on the internal Geneva gear corresponding with the actual position of the contacts.

Another match mark is located on the side of the bracket near the Geneva pinion on the centerline for the Geneva pinion shaft bearing. When this match mark is in line with a match mark on the Geneva pinion, the Geneva pinion is in the center of the locked on "On-Position" zone of the mechanism.

The external operating mechanism is connected to the tap changer drive shaft through a shaft and slip joint. This slip joint plus universal joints permit tank expansion and slight shaft misalignment without hindrance to operation. When a tap changer or external operating mechanism is installed in the field, a check of the slip joint for free operation should be made (see Fig. 5).

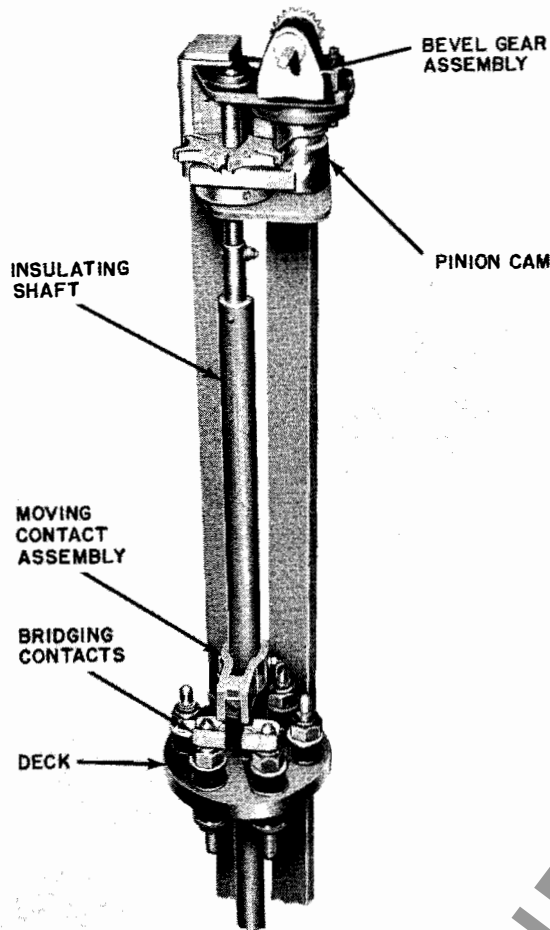

FIG. 2. Single Deck WSB-4 Tap Changer

OPERATION

One tap change requires one complete revolution of the external operating handle which is connected to the shaft assembly for transfer into the transformer case through an oil-and-gas-tight stuffing gland. A position indicator is geared to the operating handle and provision is made for locking the mechanism on each position by Geneva gears.

Motion of the tap changer operating handle is transmitted through the shaft assembly to the ninety degree Geneva gearing in the internal tap changer housing. This gearing provides the motion which lifts the moving contacts and rotates them to a new tap position. Cam action in the gearing maintains a closed circuit condition through forty-five degrees of rotation of the operating shaft, thus eliminating the need for extreme accuracy in pinning the handle to the operating shaft in cases of field assembly. A Geneva gear locking arrangement in the tap changer mechanism locks the polyester glass

shaft against rotation, except when the contacts are lifted to change position.

Silver plated copper bridging contacts which move around the circle of fixed contacts provide a connection between any two adjacent contact points. The bridging contacts are spring loaded and supported from an overhead assembly. This assembly is attached to the polyester glass shaft which passes through the center of each deck.

The connection diagram of the five position WSB-4 tap changer is shown in Fig. 3. For this Tap Changer the studs are bolted to the molded deck. When less than the standard number of six taps and five positions are supplied, a stop is provided on the external operating mechanism to prevent operating the tap changer on unconnected positions.

An 8 stud 7 position tap changer deck is shown in Fig. 4. Here again, a stop prevents operations on other than the positions intended.

MAINTENANCE

The WSB-4 tap changer is designed to operate without maintenance; however, the moving and/or stationary contacts may be removed for replacement or repair in case of minor damage. Unit replacement is recommended in case of breakdown.

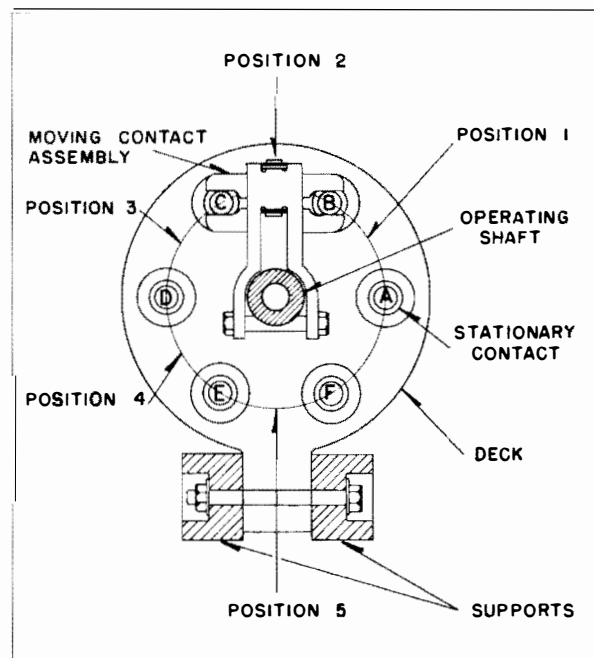

FIG. 3. Connection Diagram for WSB-4 Tap Changer with 6 Terminal Deck

Replacement WSB-4 tap changers will be supplied with leads installed in the studs by high pressure indentation. This eliminates any need for brazing on the tap changer studs and also provides sufficient cables to compensate for that cable which is cut off in removing the old tap change.

When a tap changer must be replaced, the leads should be cut off as close to the tap changer as conveniently possible to make available ample cable for splicing to the new tap changer.

It is desirable to make the brazed connection as far as possible from both the tap changer and the coil to prevent excessive heating of either the coil or the tap changer.

Refer to Installation on page 1 for further instructions.

RENEWAL PARTS

Order renewal parts from the nearest Westinghouse office. Include a complete description

of the part wanted along with the data on the nameplate attached to the transformer tank wall.

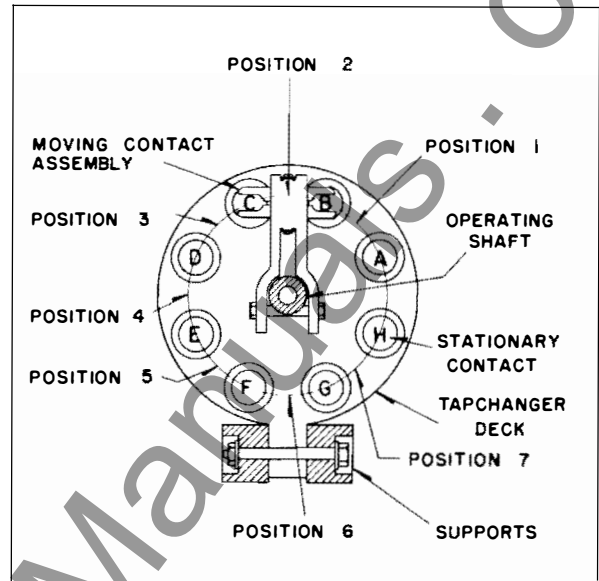

FIG. 4. Connection Diagram for WSB-4 Tap Changer with 8 Terminal Deck

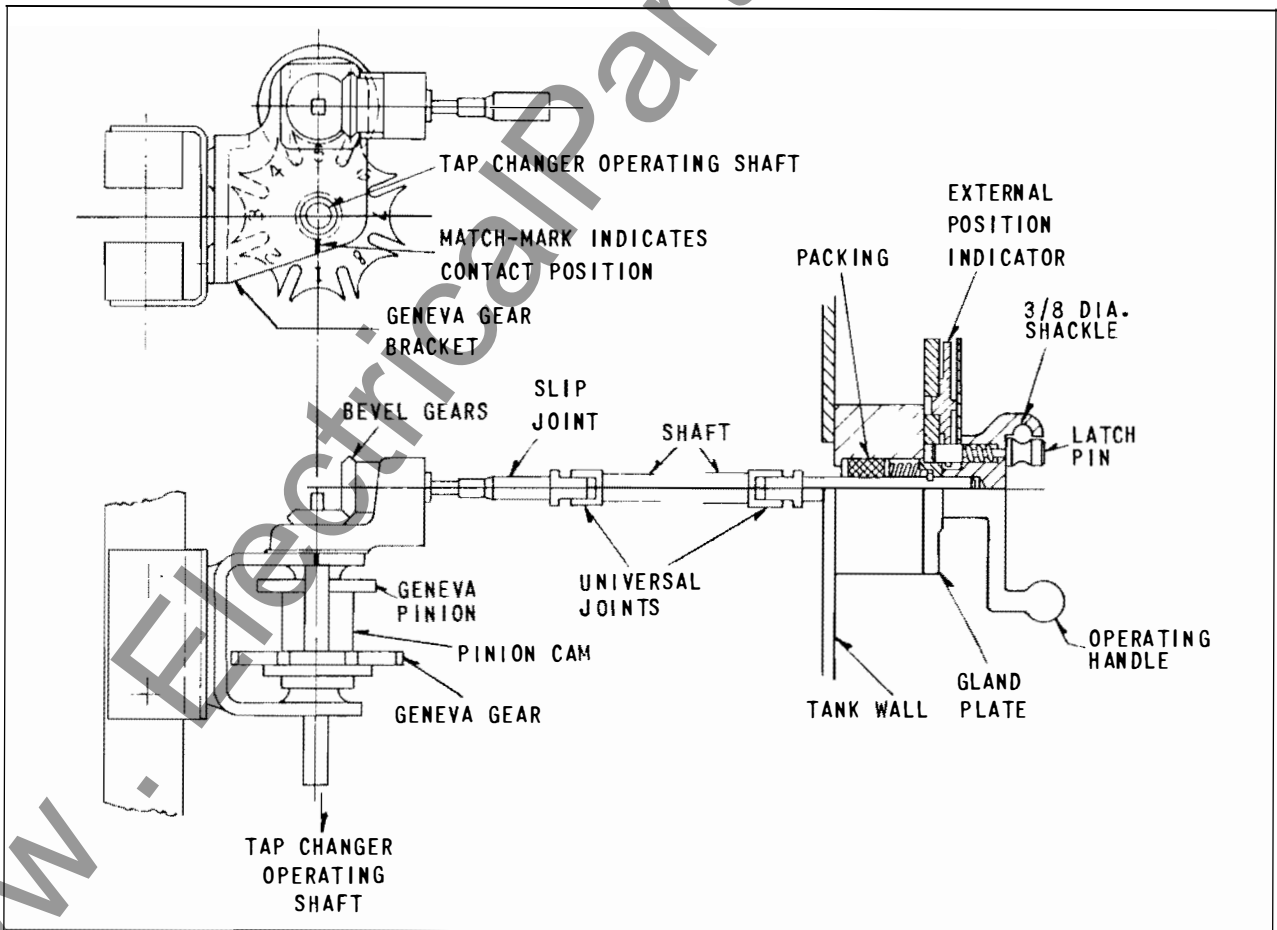

FIG. 5. Outline of Type WSB-4 No-Load Tap Changer Operating Mechanism Mounted on Transformer (In Top View, Looking Down, Tap Changer is on Position 1)

www.ElectricalPartManuals.com



WESTINGHOUSE ELECTRIC CORPORATION
SHARON PLANT • TRANSFORMER DIVISION • SHARON, PA.

Printed in U.S.A.

Instructions for No Load Tap Changer Type WSS Center Drive



I.L. 48-064-29A

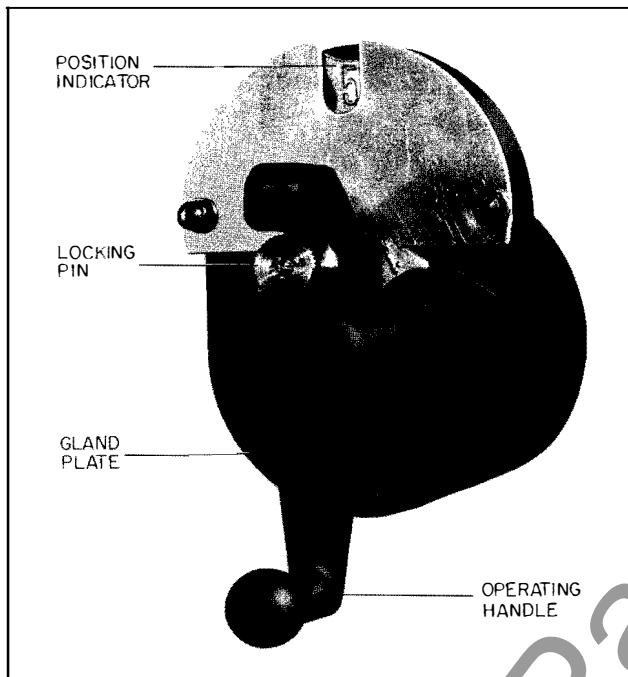

Fig. 1 Operating Mechanism Position Indicator

The Type WSS Tap Changer provides an adequate and convenient method for changing transformer tap connections from outside the transformer case. The tap changer is mounted under oil in the transformer case and is intended for operation only when the transformer is disconnected from the line.

IMPORTANT: No-load tap changers must not be operated with the transformer energized; the transformer must not be energized unless the tap changer is locked on an operating position (see transformer nameplate).

The Type WSS Center Drive Tap Changer is made for 3 phase 15 KV, 250 amperes (maximum) at 4500 ampere short circuit rating for 2 seconds. When less than three phases or five positions are required, the unused contacts are omitted from the assembly and a stop provided on the external operating mechanism. The stationary contacts, with provision on one end for connecting the leads, are through type studs

mounted in a thermoset plastic channel and are arranged in a straight line parallel to the motion of the moving contacts. Good connections are assured by silver plated wiping contacts and by high pressure indentation of the stud onto the tap leads. The free end of the stationary contacts are crimped to prevent their removal. See Figure 2.

INSTALLATION

Tap changers are usually shipped mounted on the core and coil assembly and connected to the external operating mechanism. Hence, when shipment of the core and coil assembly is made separately from the tank and fittings, it is necessary to make the connection of the tap changer drive shaft to the external operating mechanism on assembly in the field.

Before pinning the shaft, when installing a new tap changer, it is essential that the position indicated by the external position indicator agree with the actual position of the tap changer contacts. See Figures 1 and 3 for relationship between tap changer position and position number of external mechanism. The location of Number 1 position depends from which side the tap changer is driven.

Match marks are provided near the pinion bearing to aid in setting the tap changer "ON" position. The moving contact is in the center of the "ON" position zone when the match mark on the pinion shaft lines up with the match mark on the stationary channel.

The external operating mechanism is connected to the tap changer drive shaft through a shaft and slip joint. This slip joint plus flexible shafts permit tank expansion and slight shaft misalignment without hindrance to operation. When a tap changer or external operating mechanism is installed in the field, a check of the slip joint for free operation should be made (See Fig. 4).

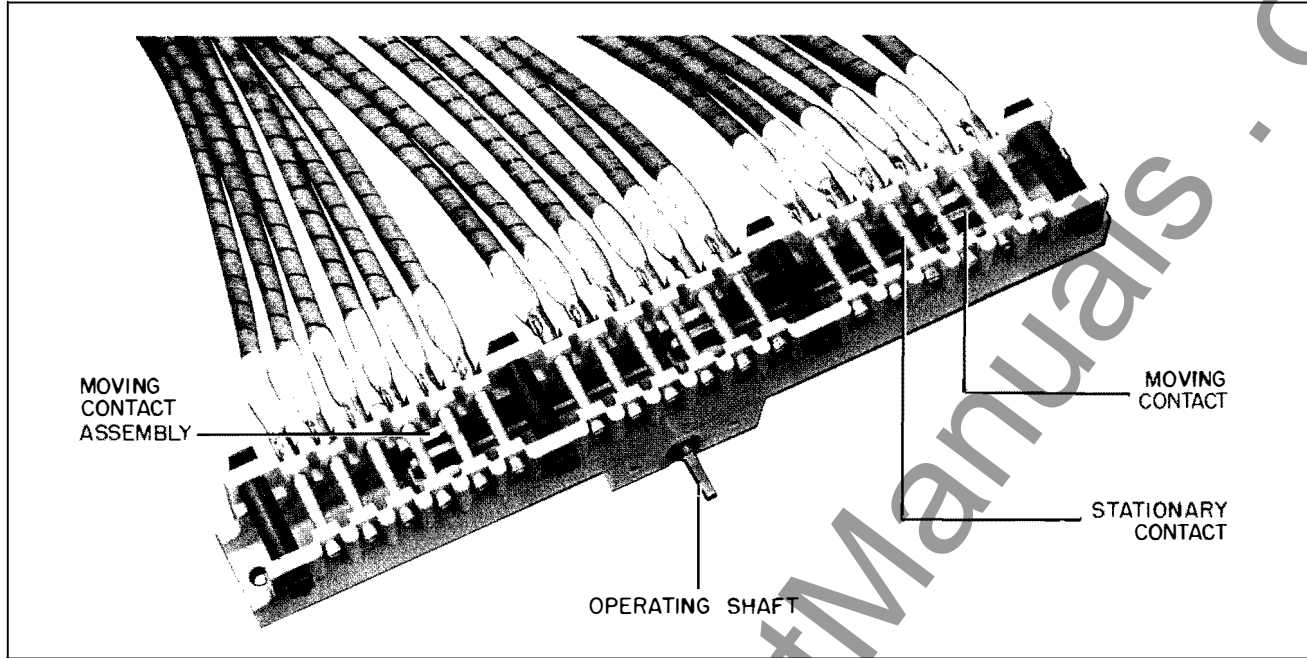

Fig. 2 Three Phase WSS Center Drive Tap Changer

OPERATION

One tap change requires one complete revolution of the external operating handle which is connected to the shaft assembly for transfer into the transformer case through an oil-and-gas-tight stuffing gland. A position indicator is geared to the operating handle and provision is made for locking the mechanism on each position by Geneva gears.

Motion of the tap changer operating handle is transmitted through the shaft assembly to the rack and pinion gearing in the center of the assembly. This gearing provides the motion which moves the moving contacts to a new position. The long sliding contact surfaces of the moving contacts maintains a closed circuit condition through forty-five degrees of rotation of the operating shaft thus neutralizing the effect of small wind-up of shaft, play in slip joints and minor inaccuracies that might occur in pinning the handle to the shaft in cases of field assembly.

A bridging contact in each phase moves along a straight line of fixed contacts to

provide a connection between two adjacent stationary contacts on each position. The bridging contacts are spring loaded and supported by a sliding channel. This assembly is moved forward or backward by the rack and pinion at the center of the stationary channel.

The connection diagram of the five position WSS tap changer is shown in Figure 3. For this tap changer, the studs are supported by the molded channel. When less than the standard number of six taps and five positions are supplied, a stop is provided on the external operating mechanism to prevent operating the tap changer on unconnected positions.

MAINTENANCE

The WSS tap changer is designed to operate without maintenance; however, the moving contacts may be removed for replacement or repair in case of minor damage. Unit replacement is recommended in case of breakdown.

When replacing the tap changer cut its leads as close to the tap changer as possible

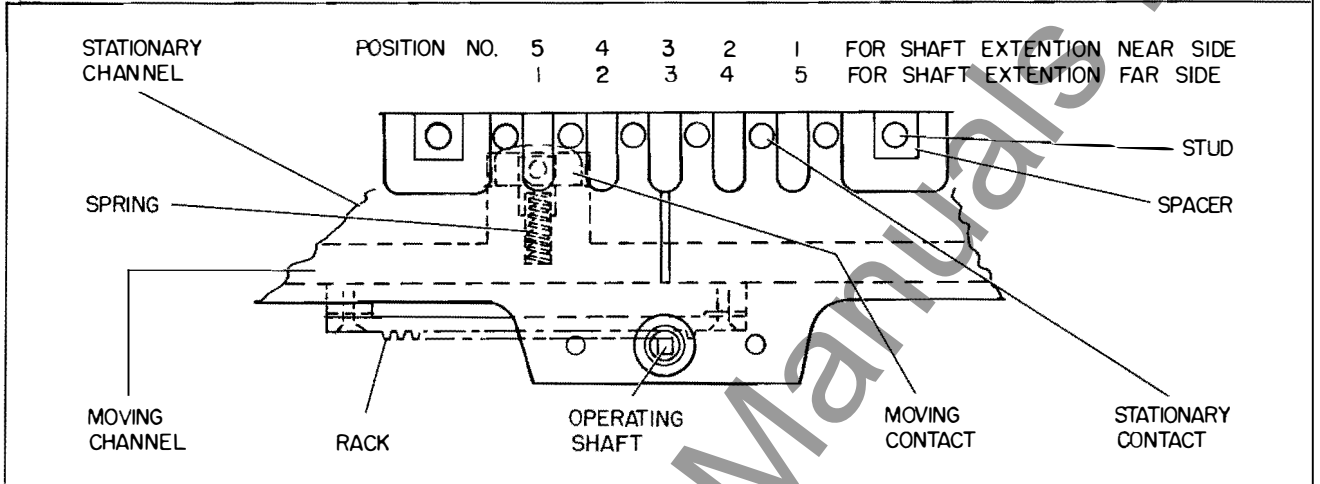

Fig. 3 Position Numbering for WSS Center Drive Tap Changer

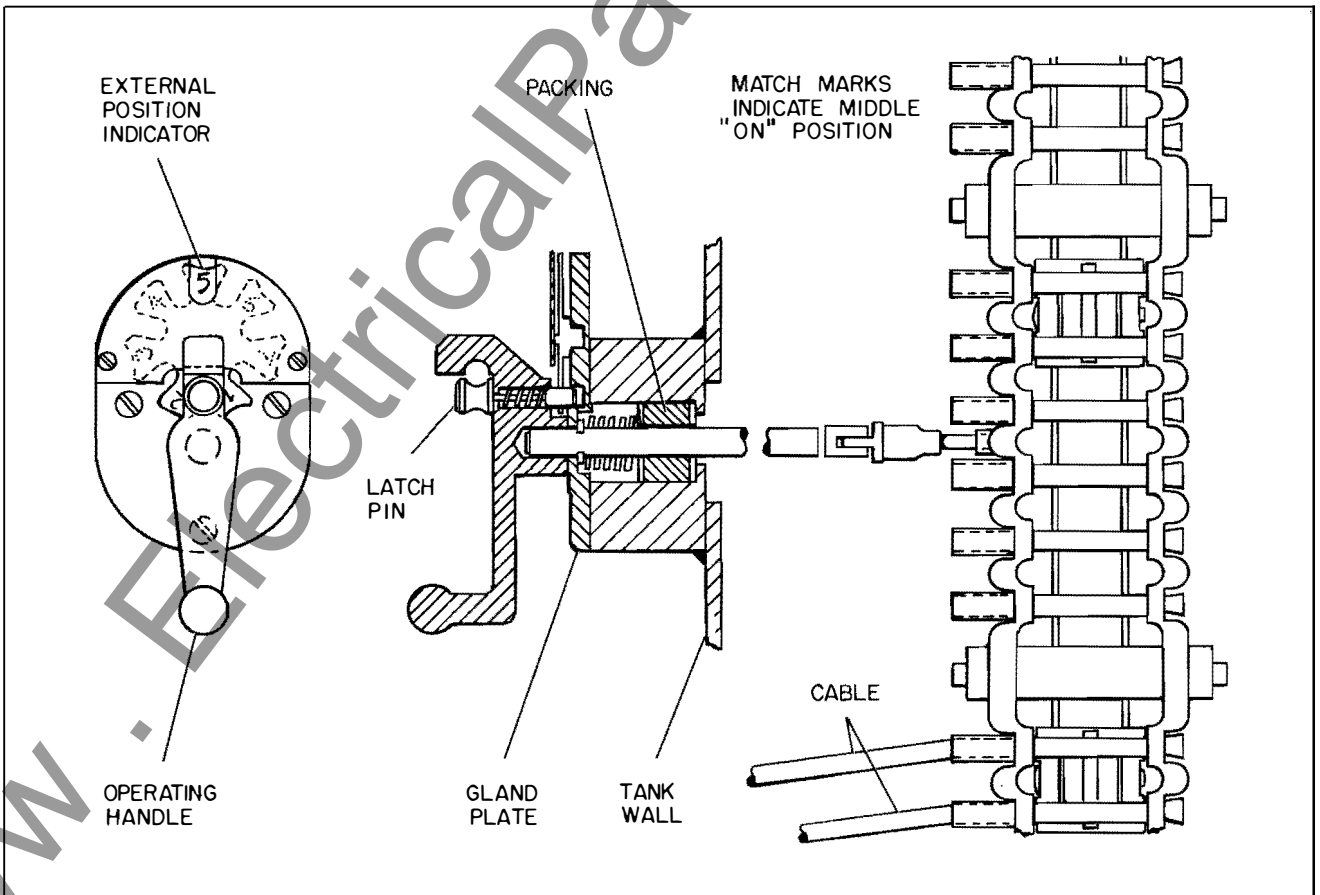

Fig. 4 Type WSS Center Drive No-Load Tap Changer with Operating Mechanism

to provide sufficient cable length for splicing to the new tap changer's leads.

Replacement WSS Tap Changers are supplied with leads attached which compensates for cable length lost in removing the old tap changer.

Make the brazed splice as far as possible from both the tap changer and the coil to prevent excessive heating of either the coil or the tap changer.

Refer to Installation on page 1 for further instructions.

RENEWAL PARTS

Order renewal parts from the nearest Westinghouse office. Include a complete description of the part wanted along with the data on the nameplate attached to the transformer tank wall.

Instructions for No Load Tap Changer Type WSS Center Drive



I.L. 48-064-29A

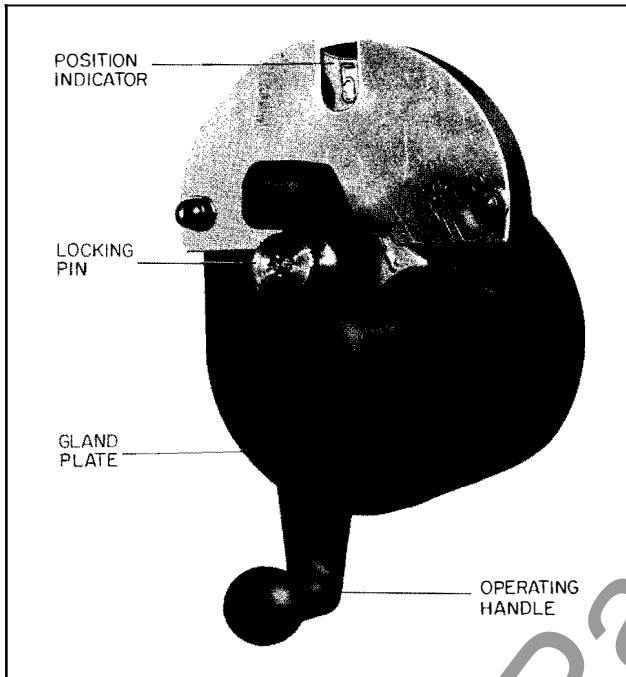

Fig. 1 Operating Mechanism Position Indicator

The Type WSS Tap Changer provides an adequate and convenient method for changing transformer tap connections from outside the transformer case. The tap changer is mounted under oil in the transformer case and is intended for operation only when the transformer is disconnected from the line.

IMPORTANT: No-load tap changers must not be operated with the transformer energized; the transformer must not be energized unless the tap changer is locked on an operating position (see transformer nameplate).

The Type WSS Center Drive Tap Changer is made for 3 phase 15 KV, 250 amperes (maximum) at 4500 ampere short circuit rating for 2 seconds. When less than three phases or five positions are required, the unused contacts are omitted from the assembly and a stop provided on the external operating mechanism. The stationary contacts, with provision on one end for connecting the leads, are through type studs

mounted in a thermoset plastic channel and are arranged in a straight line parallel to the motion of the moving contacts. Good connections are assured by silver plated wiping contacts and by high pressure indentation of the stud onto the tap leads. The free end of the stationary contacts are crimped to prevent their removal. See Figure 2.

INSTALLATION

Tap changers are usually shipped mounted on the core and coil assembly and connected to the external operating mechanism. Hence, when shipment of the core and coil assembly is made separately from the tank and fittings, it is necessary to make the connection of the tap changer drive shaft to the external operating mechanism on assembly in the field.

Before pinning the shaft, when installing a new tap changer, it is essential that the position indicated by the external position indicator agree with the actual position of the tap changer contacts. See Figures 1 and 3 for relationship between tap changer position and position number of external mechanism. The location of Number 1 position depends from which side the tap changer is driven.

Match marks are provided near the pinion bearing to aid in setting the tap changer "ON" position. The moving contact is in the center of the "ON" position zone when the match mark on the pinion shaft lines up with the match mark on the stationary channel.

The external operating mechanism is connected to the tap changer drive shaft through a shaft and slip joint. This slip joint plus flexible shafts permit tank expansion and slight shaft misalignment without hindrance to operation. When a tap changer or external operating mechanism is installed in the field, a check of the slip joint for free operation should be made (See Fig. 4).

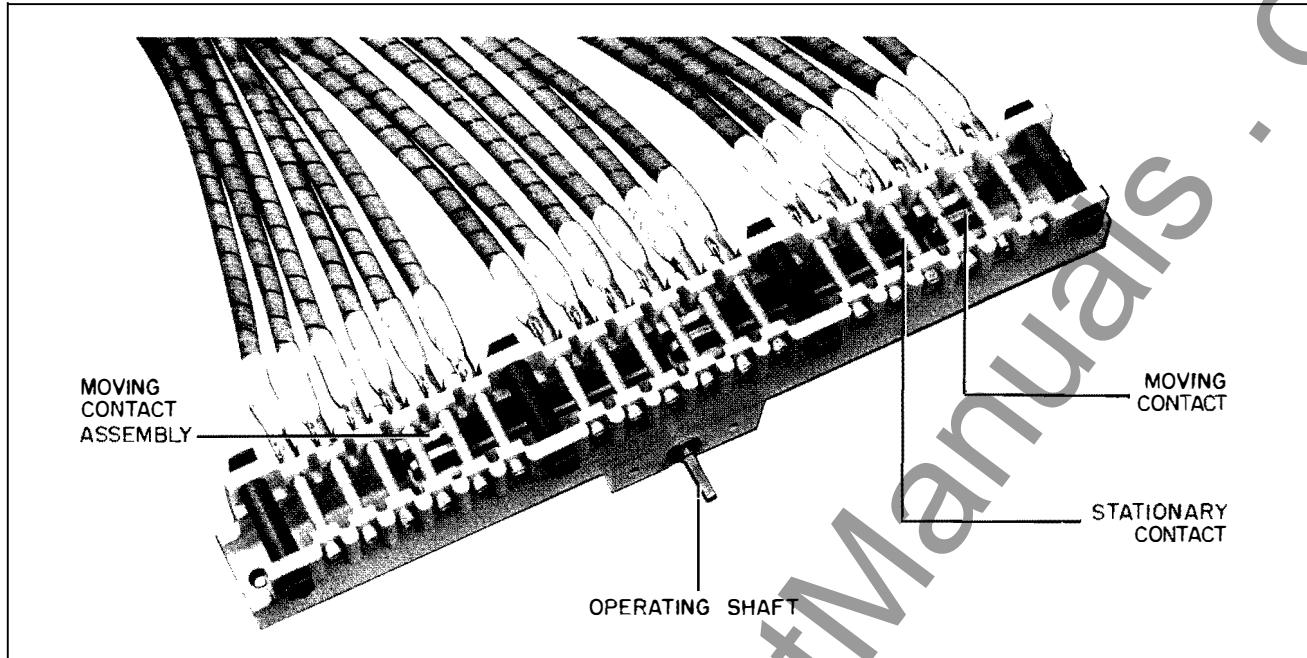

Fig. 2 Three Phase WSS Center Drive Tap Changer

OPERATION

One tap change requires one complete revolution of the external operating handle which is connected to the shaft assembly for transfer into the transformer case through an oil-and-gas-tight stuffing gland. A position indicator is geared to the operating handle and provision is made for locking the mechanism on each position by Geneva gears.

Motion of the tap changer operating handle is transmitted through the shaft assembly to the rack and pinion gearing in the center of the assembly. This gearing provides the motion which moves the moving contacts to a new position. The long sliding contact surfaces of the moving contacts maintains a closed circuit condition through forty-five degrees of rotation of the operating shaft thus neutralizing the effect of small wind-up of shaft, play in slip joints and minor inaccuracies that might occur in pinning the handle to the shaft in cases of field assembly.

A bridging contact in each phase moves along a straight line of fixed contacts to

provide a connection between two adjacent stationary contacts on each position. The bridging contacts are spring loaded and supported by a sliding channel. This assembly is moved forward or backward by the rack and pinion at the center of the stationary channel.

The connection diagram of the five position WSS tap changer is shown in Figure 3. For this tap changer, the studs are supported by the molded channel. When less than the standard number of six taps and five positions are supplied, a stop is provided on the external operating mechanism to prevent operating the tap changer on unconnected positions.

MAINTENANCE

The WSS tap changer is designed to operate without maintenance; however, the moving contacts may be removed for replacement or repair in case of minor damage. Unit replacement is recommended in case of breakdown.

When replacing the tap changer cut its leads as close to the tap changer as possible

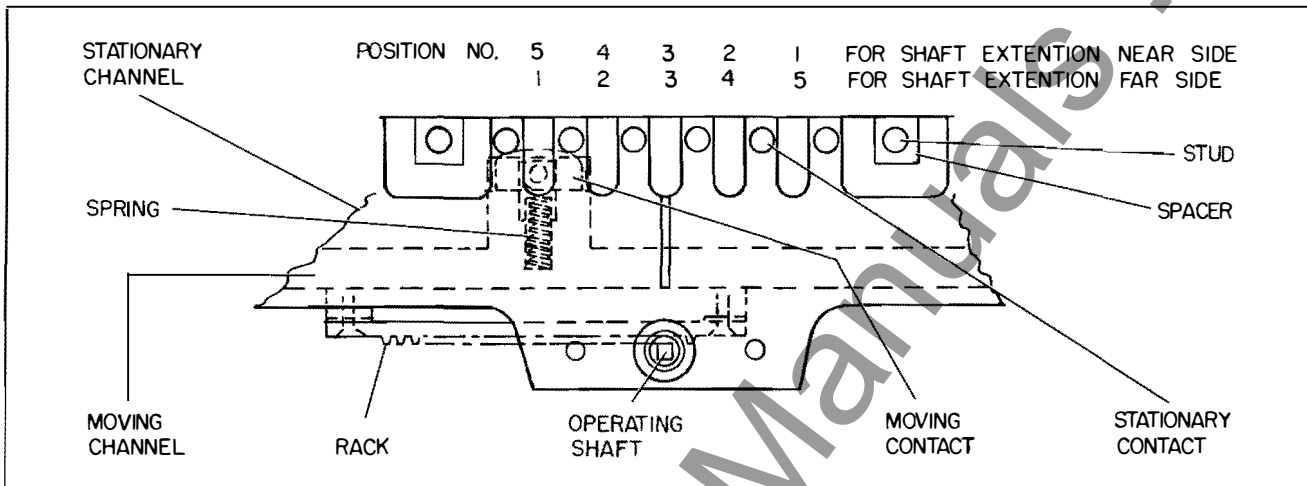

Fig. 3 Position Numbering for WSS Center Drive Tap Changer

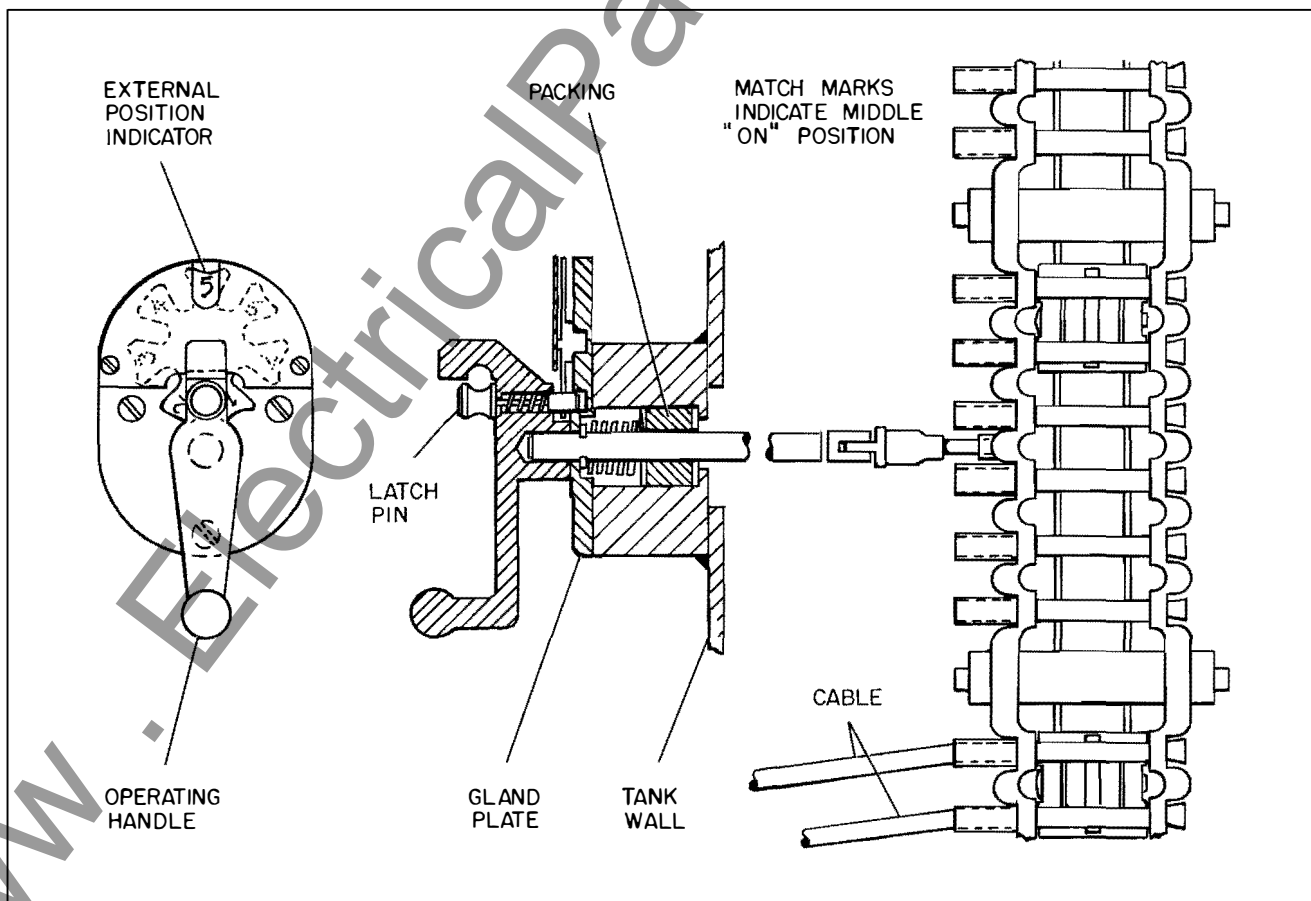

Fig. 4 Type WSS Center Drive No-Load Tap Changer with Operating Mechanism

to provide sufficient cable length for splicing to the new tap changer's leads.

Replacement WSS Tap Changers are supplied with leads attached which compensates for cable length lost in removing the old tap changer.

Make the brazed splice as far as possible from both the tap changer and the coil to prevent excessive heating of either the coil or the tap changer.

Refer to Installation on page 1 for further instructions.

RENEWAL PARTS

Order renewal parts from the nearest Westinghouse office. Include a complete description of the part wanted along with the data on the nameplate attached to the transformer tank wall.