

Control Circuits for CSP Power Transformers

Circuits with Reverse Power Relaying

INSTRUCTIONS

GENERAL

The "CSP" power transformer for use on feeders where there is possibility of reverse power flow requires control circuits to perform the following functions:

- 1—To regulate the voltage.
- 2—To protect the transformer against faults in the secondary circuits connected to the transformer.
- 3—To open the air switch in case of reverse power flow through the transformer.
- 4—To protect against overheating the transformer, but to allow useful loads up to the thermal capacity of the transformer.
- 5—To meter the transformer output.

The circuits to perform these functions along with the circuits for manual control are described in the following paragraphs. The circuits only are described in this leaflet; the relays and instruments used in the circuits are individually described in separate leaflets. Figure 1 shows the circuits schematically.

OPERATION

Starting at the left side of the diagram, the circuits are arranged as nearly as possible in the sequence of their operation, and in the order in which they will be described.

1—Tap Changer Circuits

The primary relay coil P, whose voltage is supplied from the auxiliary transformer and is modified by the line drop compensator R-X-CT for voltage drop between the transformer and the load center, closes its contact PR when the load center voltage becomes low, or its contacts PL when the load center voltage becomes high. With the automatic manual transfer switch, AM, turned to "Auto" the closing of PR or PL energizes time delay relay TR or TL, which immediately seals itself by closing contact TR3 or TL3.

After one-half of the timing period of TR or TL, this relay opens its contacts TR2 or TL2 so that if the primary relay opens its contacts PR or PL, the corresponding time delay relay TR or TL is deenergized and resets instead of completing the timing cycle. If PR or PL remains closed, TR or TL continues to operate during the second half of the timing period, and at the end of this closes its contacts TR1 or TL1 to energize motor control relay SR or SL.

Motor control relay SR or SL performs the following functions. Contacts SR2 or SL2 seal in relay TR or TL so that once contacts TR1 or TL1 have

closed, they remain closed, even if PR or PL opens. Contacts SR4 or SL4 energize the brake "B" and release it. Contacts SR3 or SL3 energize the motor "M" and its associated capacitor "C" to operate the tap changer in the proper direction to raise or lower the line voltage. Very soon after the tap changer starts, contact 120 is mechanically closed by the tap changer operating mechanism and seals motor control relay SR or SL through its contacts SR1 or SL1, so that the tap changer will continue to operate as long as switch 120 remains closed, regardless of the action of the primary and time delay relays.

Immediately after switch 120 is mechanically closed and the motor circuit is sealed, switch 123 is mechanically opened. If switch M23 is set on "Non-Sequential", this positively opens all circuits to the time delay relay TR or TL so that this relay completely resets almost instantaneously and the primary relay must again close for the entire time delay period before another tap change can be started. If switch M23 is set on "Sequential" opening switch 123 opens the sealing circuit through contacts SR2 or SL2, but does not open the circuit through PR or PL, so that the time delay relay will reset only if the primary relay opens. The tap changer will, therefore, continue to run through successive positions with no intermediate time delay until the primary relay opens its contacts.

After the tap changer contacts close so that the voltage of the new position is applied to the primary relay so that it will open its contacts if the voltage change has been sufficient, switch 123 is mechanically closed to restore the circuits to the time delay relays, then switch 120 is mechanically opened so that it deenergizes the motor control relay SR or SL, which opens its contacts deenergizing the motor and applying the brake to stop the tap changer on position.

Manual control is provided by switches MCR and MCL which by-pass the contacts of the time delay relay and which can be manually operated to energize the motor control relays whenever the automatic-manual transfer switch is set on "Manual."

To make certain that a voltage interruption during a tap change will not leave the tap changer indefinitely between operating positions, back contact SR5 is provided on the motor control relay. If, between positions, the voltage is interrupted, dropping out relay SR or SL, switch 120 will be closed. Then, as soon as voltage is restored, the circuit

will be complete to immediately energize relay SL and operate the tap changer to its next lower operating position.

Mechanically operated switch 117 is closed on all even numbered positions. If toggle switch M17 is closed, switch 117 by-passes switch 120 on alternate positions and the tap changer will stop only on odd numbered positions.

The thermoguard, TG, is mounted on the motor "M" to protect it against thermal overload and thereby to prevent burnout. This device is self-resetting when the motor cools.

Limit switches LR and 124 open on the maximum boost position of the tap changer and limit switches LL and 125 open on the maximum buck position of the tap changer and prevent attempted operation beyond the range of the regulating equipment.

Interlocking switch IS1, is mechanically opened whenever the hand crank is engaged, so that the mechanism cannot operate electrically while an operator is turning it by hand.

The interlocking contact 152-A is mechanically opened by the air switch when the air switch opens, so that the tap changer can operate automatically only when the air switch is closed.

2—Indicating and Utility Circuits

Mechanically operated switch 121 is closed between positions and open on all operating positions. It operates the counter OC to record the number of tap changer operations, and the red light RL, which shows whenever the tap changer is not on a normal operating position.

Convenience outlet ES is provided.

The lights, DL, operated by toggle switch DLS are provided to illuminate the control panels and the control compartments of the tank.

Indicating circuits are provided to show when the transformer is overheated and to show whether the air switch is open or closed.

The amber signal lamps, AL, are mounted on an external wall of the transformer where they are visible from the outside, and are operated by the signal light contacts 151BL of the thermal relay 151-B. The signal circuit also includes the resetting coil 151BRS, which operates to reset the thermal relay contacts by closing switch RS. Switch "RS" incorporates a thermal timing device which makes it impossible to hold contacts RS closed long enough to overheat the resetting coil 151BRS.

Control Circuits for CSP Power Transformers—Continued

Whenever the air switch is closed, it mechanically opens switch 152B and closes switch 152A. When the air switch is open, it mechanically closes switch 152B and opens switch 152A. Therefore, corresponding red light "RL" will be lighted whenever the air switch is closed, and green light "GL" will be lighted whenever the air switch is open.

3—Metering

A three-element watt-hour meter, or a three-element watt-hour demand meter is connected as shown at WHM with one element connected in each phase. Test switches TS2 and TS3 are provided for isolating and testing the meter.

4—Tripping Circuits

The tripping circuits utilize both current trip coils and voltage trip coils and provide for tripping under any type of fault which the air switch control is designed to protect against.

The overcurrent relay 151, one in each phase, opens its contacts 151 when the current through the coil exceeds the value for which the relay is adjusted. Opening contacts 151 cause the current to flow through the current trip coil 152CT and open the air switch.

The three phase reverse power relay having current coils CN-33 and voltage coil CN-POT, operates to close its contact CN-33 whenever the power flow through the transformer reverses. If the current is larger than the setting of the desensitizing relay, BN, element BN operates to close contact BN which completes the circuit through contact CN-33 to trip coil 152-PT to open the air switch. If the current is too small to trip the air switch in this way, it will be tripped by a timing sequence as follows: closing CN-33 energizes timing element BNT, which operates with time delay to open the normally closed contact BNT, and close the other contact BNT. When the normally open contact closes, it energizes element BNSG which opens the circuit to timer BNT, seals itself, and closes the contact between contacts BNT and trip coil 152PT. Then, after BNT is deenergized, a further time delay is obtained while normally open contact BNT reopens and normally closed contact BNT closes to trip the air switch.

The thermal relay contacts, 151BT1 and the manual control switch trip contacts, 101T1, are connected to close the circuit to the potential trip coil, 152PT, to open the air switch. When the air switch opens, mechanically operated switch 152A opens so that the trip coil cannot be energized continuously.

The potential trip coil is energized through one or the other of contacts SV from terminal 49 or terminal 50 of the auxiliary transformer, depending upon

the voltage of the system. When the system voltage is normal, relay SV opens its normally closed contact connected to the 230-volt terminal 50 and closes its other contact, connecting to the 115-volt terminal 49. If the system voltage drops below approximately 70 volts, due to unusual short-circuit conditions which do not cause over-current tripping, the relay SV will drop open, thereby doubling the voltage otherwise available to the potential trip coil. The potential trip coil is thus made operative with bus voltages as low as 20 to 25 volts, secondary.

5—Closing Circuits

The automatic reclosing is accomplished by means of the reclosing relay which comprises the devices on the diagram having the number 179.

When the manual control switch has been turned to "trip", contact 101SC is open and remains open until the manual control switch is turned to "close". Contacts 151BT2 are closed unless the thermal relay has opened the air switch because of excessive winding temperature. Relays SGB and SGC will close only when voltage is approximately normal on phases B and C and will prevent reclosing after reverse power tripping if voltage is not restored to phases B and C. The recloser itself will prevent reclosing unless there is voltage on phase A. Therefore, if the last operation on the manual control switch was to close the air switch, if the transformer has not been overloaded, and if voltage is restored to all phases, and further, if the manually operated cutout switch 143 is closed, the circuits are ready to reclose the air switch.

As soon as the air switch trips, mechanically operated contacts 152B close and energize motor 179M, which starts the recloser timing sequence. After the recloser motor runs a short time, contact 179-2 also closes and the recloser will then run through 152B and 179-1 if the air switch is open, and through 152A and 179-2 if the air switch is closed. At the end of the timing sequence, contact 179-1 opens first, and if at that time the air switch is open so that the motor is operating through contact 152B, the recloser will stop. This is the lock-out position. If, on the other hand, the air switch is closed so that the motor is operating through contacts 152A, the recloser will continue until 179-1 closes and 179-2 opens to stop the recloser.

At preset adjustable intervals during the timing sequence, contact 179-3 closes and completes the circuit through 179Y5 to 179X. Contact 179X8 seals in coil 179X. Contact 179X9 energizes

coil 179Y, which opens contact 179Y5 and closes contacts 179Y7 and 179Y6. Closing 179Y6 energizes the closing contactor 152X. Contact 152X1 seals in coil 152X and contact 152X2 operates the air switch closing solenoid 152C through the rectox rectifier "RX".

When the air switch closes, contacts 152AA are mechanically closed to energize relay 152Y which closes contacts 152Y1 to seal itself until 151X1 and 101C1 open and opens contacts 152Y2 to deenergize contactor 152X, and contacts 152B are mechanically opened to deenergize relays 179X and 179Y. Relay 179X immediately opens its contacts, but relay 179Y opens only contact 179Y6. Contacts 179Y5 remain open, and contacts 179Y7 remain closed. As long as 179Y7 remains closed, the motor 179M will run even though the air switch has closed to close contact 152A and the timing sequence has not gone far enough to close 179-2. This relay can, therefore, be used for instantaneous reclosing service. As long as 179Y5 remains open, relay 179X will not be energized again, even though 179-3 is still closed. After the timing mechanism has gone far enough to close 179-2 and open 179-3, it mechanically releases 179Y so that contacts 179Y7 open and 179Y5 close, and the relay is then ready for the next operation of 179-3.

When the air switch is closed manually, contact 101C1 is closed to energize the closing contactor 152X and close the air switch by means of closing coil 152C and rectifier RX. At the same time that 101C1 is closed, 101C2 is closed. When the air switch closes, mechanically operated contacts 152AA close and operate relay 152ZB, which closes contact 152ZB and opens contacts 152ZA. Opening 152ZA makes it impossible for 101C1 to energize the closing contactor 152X for a second operation. When the manual control switch is turned to "trip", or when switch 143 is closed, relay 152ZA is energized and closes contacts 152ZA and opens contacts 152ZB, restoring the circuits to their original state. Contacts 101-OT are provided, and are open only when the manual control switch is turned to "close", to prevent chattering of relays 152ZA and 152ZB, in case switch 143 is not open when control switch 101C2 is closed.

6—Variations

The above description applies to a standard "CSP" power transformer. Special requirements on individual orders may necessitate minor variations from this description. In using this leaflet, therefore, reference should also be made to the schematic wiring diagram supplied with the transformer.

Westinghouse Electric & Manufacturing Company

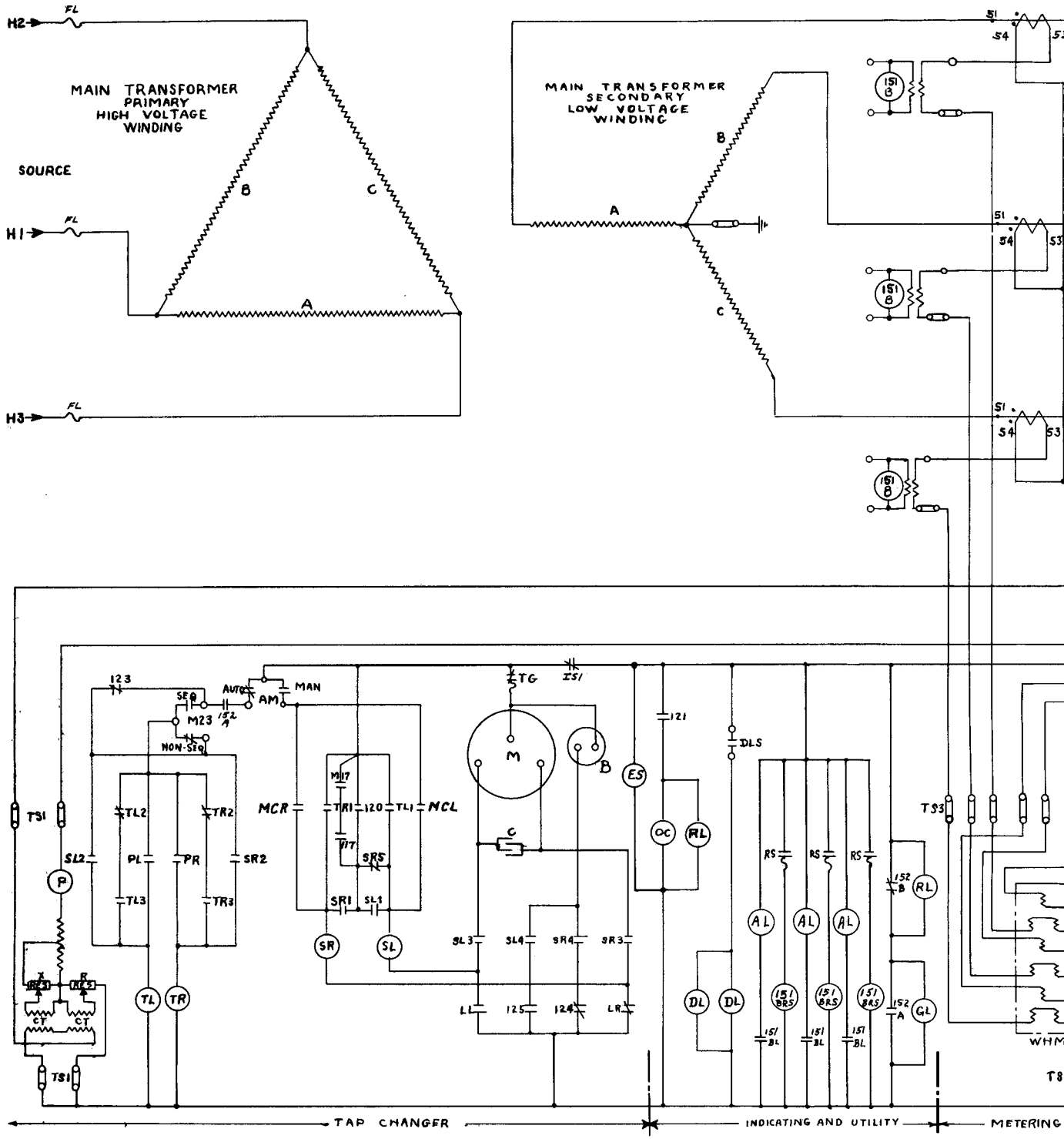

Figure



64



65



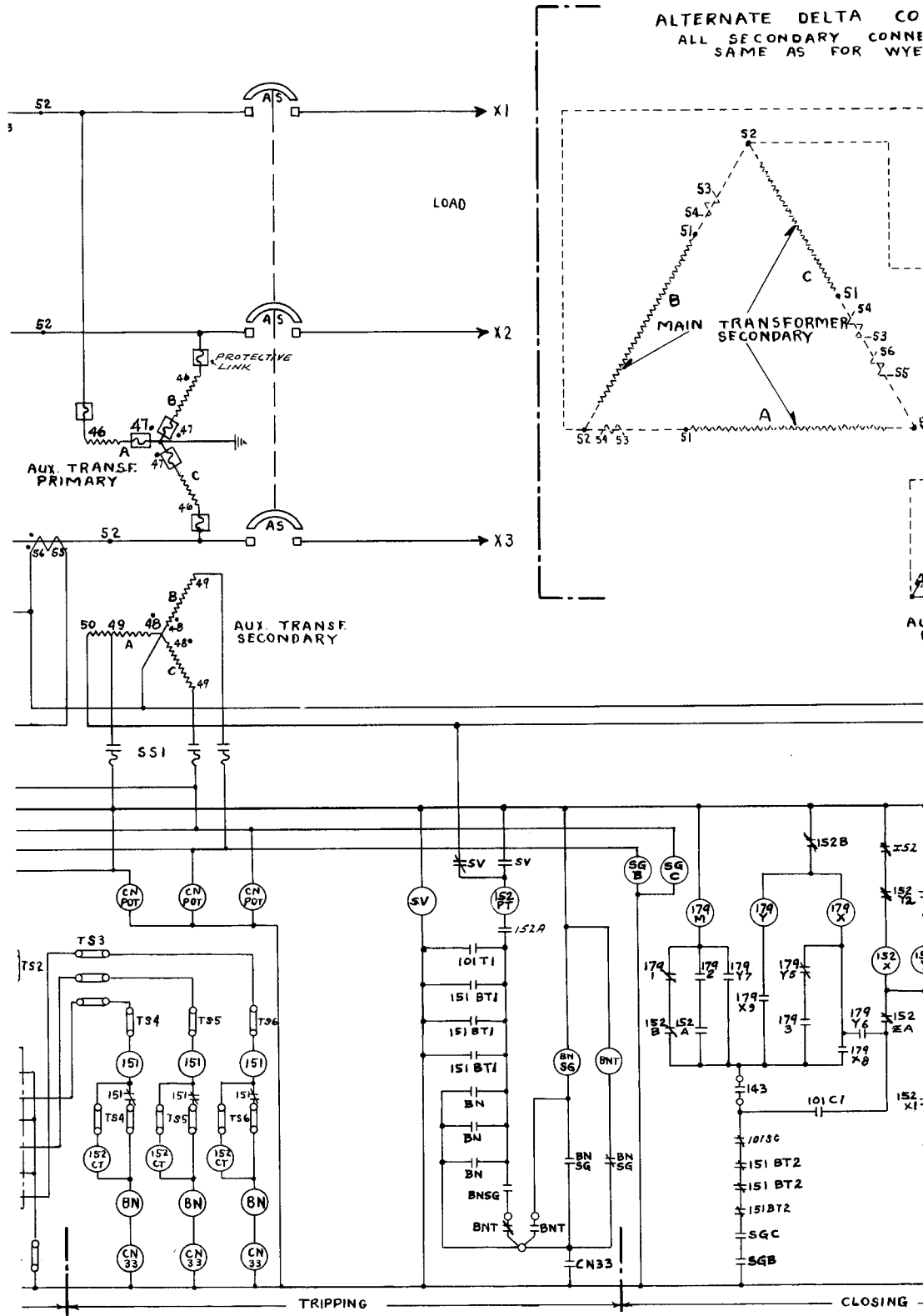

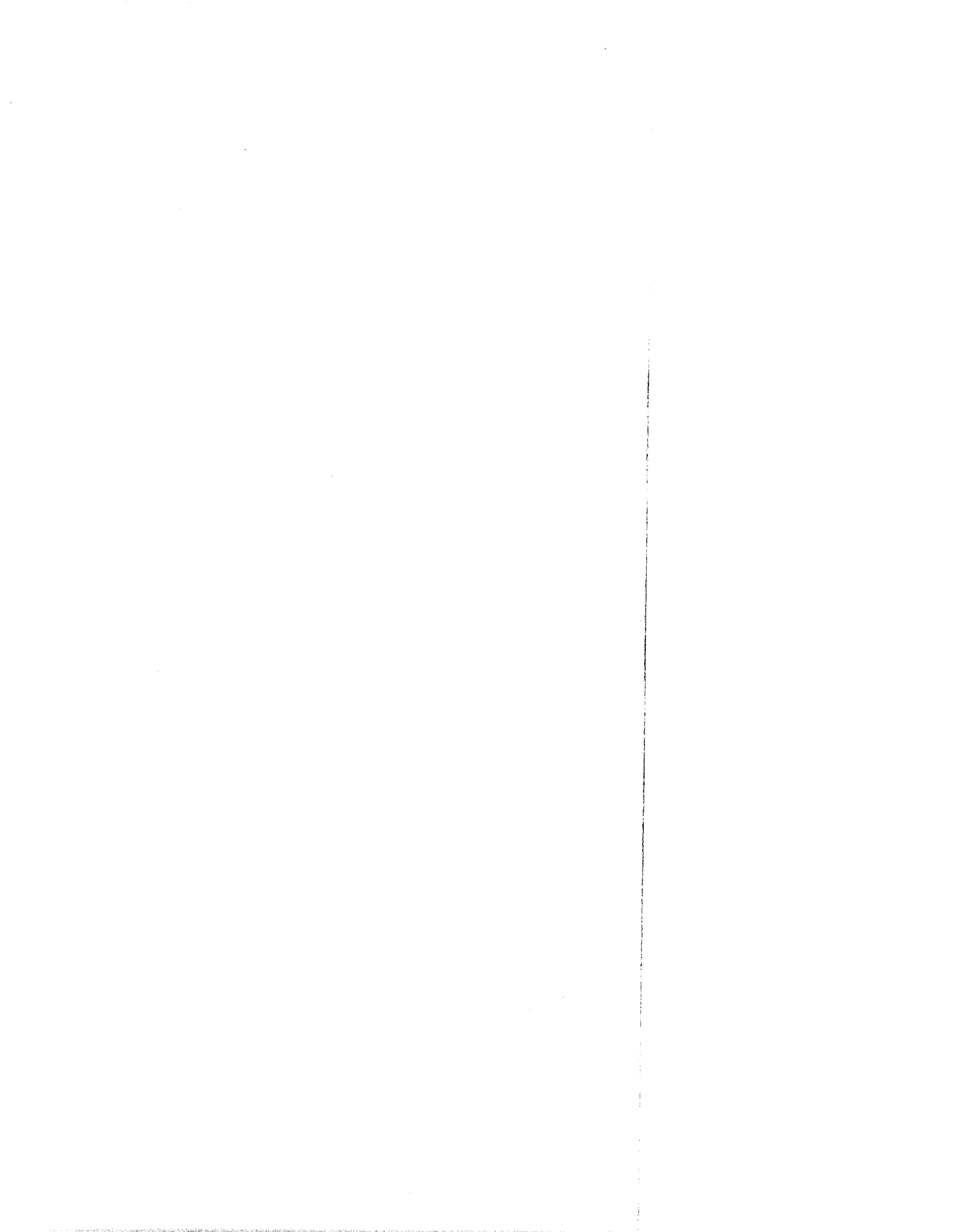

CONNECTION
FUNCTIONS

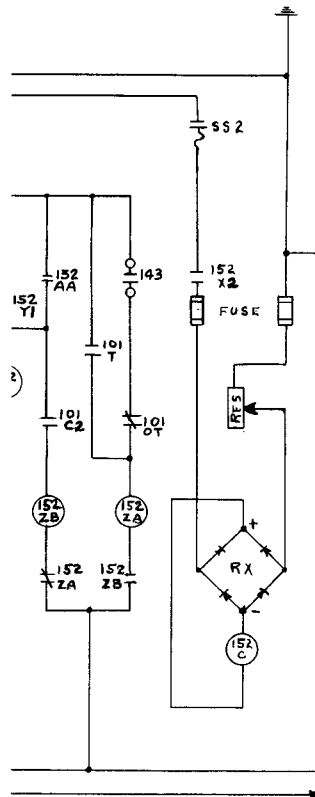
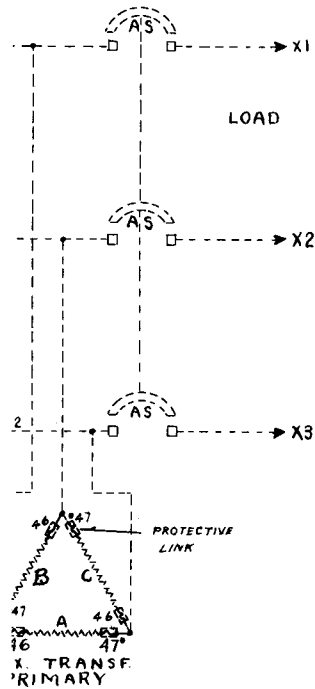

LIST OF APPARATUS		
DEVICE NO	DESCRIPTION	OPER BY
AS	AIR SWITCH	ELEC.
P	PRIMARY RELAY - TYPE "SU"	"
PR	" " CONTACT - RAISE	"
PL	" " " LOWER	"
TR	TYPE "TK" TIME DELAY RELAY - RAISE	"
TL	" " " " LOWER	"
SR	" "SG" MOTOR CONTROL RELAY - RAISE	"
SL	" " " " " LOWER	"
M	MOTOR	"
B	" BRAKE	"
TG	" THERMOGUARD	"
C	CAPACITOR	"
AM	AUTOMATIC MANUAL TRANSFER SWITCH	HAND
MC	MANUAL CONTROL SWITCH	"
120, 123	PILOT SWITCHES	MECH.
LL-124 LR-125	LIMIT "	"
IS1	INTERLOCKING SWITCH - HAND CRANK	"
RL	OFF POSITION LIGHT - Red	ELEC.
OC	OPERATION COUNTER	"
TS1	TEST SWITCH - TYPE "M"	HAND.
SS1	TYPE "AB" BREAKER ON CONTROL PANEL - 15 AMP	ELEC.
M23	CHANGEOVER SW. FOR SEQ. OR NON-SEQ. OPERATION	HAND
151	TYPE "CO" RELAY - OVERCURRENT ELEMENT	ELEC.
151B	THERMAL RELAY	TEMP.
151BL	" " SIGNAL CONTACTS	"
151BT	" " TRIP "	"
151BRS	" " RESET COIL	ELEC.
152AA 152BB	AUXILIARY SWITCHES	MECH.
152A	" SW. CLOSED WHEN AIR SW. IS CLOSED	"
152B	" " " " " " OPEN	"
152C	AIR SWITCH CLOSING COIL	ELEC.
152CT	CURRENT TRIP COIL	"
152PT	POTENTIAL " "	"
152Z-A 152Z-B	TYPE "SX" ANTI-PUMP RELAY	"
152X	" "22-F-2" AUXILIARY CLOSING CONTACTOR	"
101	MANUAL CONTROL SWITCH	HAND.
BN	TYPE "BN" RELAY	ELEC.
BNT	" " " TIMING ELEMENT	"
BN5G	" " " AUXILIARY CONTACTOR	"
CNPOT	" "CN33" " - POTENTIAL COIL	"
CN33	" " " - REVERSE POWER	"
AL	AMBER SIGNAL LIGHT - THERMAL RELAY	"
RL	RED IND LIGHT - AIR SWITCH CLOSED	"
GL	GREEN " " " " OPEN	"
RS	RESET SWITCH - THERMAL RELAY	HAND
TS4-6	TYPE "M" TEST SWITCHES	"
RES	RESISTOR	ELEC.
NL	NEON LAMP	"
SV	SV RELAY	"
RX	RECTOX	"
SG 2-C	TYPE "SG" RELAYS	"
143	TOGGLE SWITCH - RECLOSING RELAY CUT OUT	HAND
17912-3	TYPE "RC" RECLOSING RELAY CONTACTS	MECH.
179X	RECLOSING RELAY - CONTACTOR	ELEC.
179Y	" " SOLENOID CONTACTOR	"
179M	" " MOTOR	"
IS2	DOOR INTERLOCKING SWITCH	MECH.
DL	PANEL LAMPS	ELEC.
TS2-3	TYPE "M" TEST SWITCHES	HAND
DL5	PANEL LAMP SWITCH TOGGLE	"
WHM	TYPE "CB-3" WATT HOUR METER	ELEC.
SS2	TYPE "AB" BREAKER ON CONTROL PANEL - 25 AMP	"
152Y	TYPE "DN" AUXILIARY CONTACTOR	"
M17	CHANGE OVER SWITCH FOR 9 OR 17 POS. OPERATION	HAND
ES	CONVENIENCE OUTLET	"
FL	PRIMARY PROTECTIVE LINK	ELEC.

- OPERATING COIL OF DEVICE AS NUMBERED
- ⊥ AUXILIARY SWITCH CONTACTS OPEN IN DE-ENERGIZED POSITION OF DEVICE.
- ⊥ AUXILIARY SWITCH CONTACTS CLOSED IN DE-ENERGIZED POSITION OF DEVICE.

