

46-060-1

**Instructions for Oil-Immersed  
Distribution Transformers  
5 to 500 KVA, 34,500 Volts  
and Below  
Single and Multi-Phase**

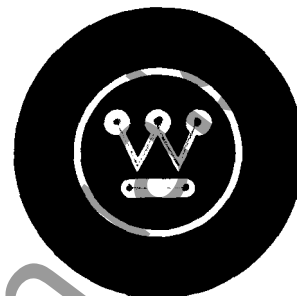

**Westinghouse Electric Corporation**

**Distribution Transformer Division, Sharon, Pa.**

**I. B. 46-060-1. Effective October, 1964. Supersedes I. B. 46-100-1A, May, 1954**

## Table Of Contents

PART ONE: DESCRIPTION	Page
Application . . . . .	5
Component Parts . . . . .	5
Transformer Type By Installation . . . . .	5
Transformer Type By Protective Devices . . . . .	5
Transformer Construction . . . . .	5
Transformer By Class . . . . .	6
Transformer Protective Devices . . . . .	6
PART TWO: INSTALLATION	
Receiving, Inspection, Handling and Storing . . . . .	9
Preparation for Installation . . . . .	9
Finish . . . . .	9
Wemco CI Oil . . . . .	9
Moisture . . . . .	9
Operator's Data . . . . .	9
Lightning Arrester Gap Settings . . . . .	10
Nameplate . . . . .	10
Protective Link Coordination . . . . .	10
Winding Connections . . . . .	11
Parallel Operation . . . . .	11
Mounting . . . . .	11
High Voltage Connections . . . . .	13
Low Voltage Connections . . . . .	13
Tank Grounding Connections . . . . .	13
Bushing Connectors . . . . .	13
PART THREE: OPERATION AND MAINTENANCE	
Operating Limits . . . . .	14
Taps . . . . .	14
Circuit Breaker Manual Operation . . . . .	14
Signal Lights . . . . .	15
Circuit Breaker Tripping . . . . .	15
Circuit Breaker Emergency Control . . . . .	15
Precautions . . . . .	16
Other Information . . . . .	17
Maintenance . . . . .	17
Renewal Parts . . . . .	18

## List of Illustrations

Figure		Page
1	Pole-Mounted Installation . . . . .	6
2	Pad-Mounted Installation . . . . .	6
3	Subway Installation . . . . .	6
4	Single-Phase, Core and Coil Construction . . . . .	7
5	Three-Phase, T-T Duplex Construction . . . . .	7
6	Three-Phase, Triplex Construction . . . . .	7
7	Class "A" Construction . . . . .	7
8	Class "B2" Construction . . . . .	7
9	Class "B3" Construction . . . . .	7
10	Circuit Breaker Protective Device . . . . .	8
11	Protective Link Device . . . . .	8
12	Lightning Arrester Protective Device . . . . .	8
13	Cover Mounted and Wall Mounted Lightning Arresters and Gap Adjustments . . . . .	10
14	Direct Pole Mounting of Distribution Transformers . . . . .	12
15	Breaker Operating Mechanism and Emergency Control, Normal and Reverse Operation . . . . .	16

## SCOPE

This instruction book has been prepared to assist the purchaser in properly installing, operating and maintaining Oil-Immersed Distribution Transformers supplied by Westinghouse. It does not, however, cover all details or variations in the product nor provide for every possible contingency met in connection with installation, operation, and maintenance. Should further instructions be desired, or should particular problems arise which are not covered sufficiently for the purchaser's purposes, the matter should be referred to the Westinghouse Electric Corporation.

## SPECIAL INQUIRIES

When communicating with Westinghouse regarding the product covered by this Instruction Book, include the serial number, style number and sub letter, type, and rating as given on the product nameplate.\* Also, to facilitate replies when particular information is required, be sure to state fully and clearly the problem and attendant conditions.

Address all communications to the nearest Westinghouse representative as listed in the back of this book.

- \* For a permanent record, it is suggested that all nameplate data be duplicated and retained in a convenient location.

NOTE: This Instruction Book includes design changes not covered by Instruction Cards 116, 2339, 2447, 2448, 2462, 2652, and Instruction Books 5379, 5922, 5922-1, 46-100-1, and 46-100-1A.

It is suggested that operators keep the older instructions on file for older transformers in service.

## Part One: Description

### APPLICATION

Oil-immersed distribution transformers are normally used for stepping public utility "distribution voltages" (ranging from 2400 to 34,500 volts) down to lower utilization voltages. Although some are used for stepping down to industrial voltages of 240/480, 2400 and 4800, most are used for stepping down to the household voltage of 120/240. These same transformers are also used for small substations and miscellaneous applications. As with any transformer, they can also serve to step-up voltages.

### COMPONENT PARTS

Oil-immersed distribution transformers consist essentially of: (1) a closed-loop magnetic steel core upon which is wound two or more separate coils; (2) a tank for containing the insulating and cooling oil in which the core-coil assembly is immersed; (3) the necessary bushings for bringing incoming and outgoing leads through the tank or cover; (4) integrally-mounted transformer protective devices such as lightning arresters, protective links and low voltage circuit breakers when ordered by the purchaser.

### TRANSFORMER TYPE BY INSTALLATION

Oil-immersed distribution transformers are designed for pole-mounting to serve overhead power distribution systems; concrete pad or surface-mounting to serve partial or entire underground systems; and mounting in underground vaults (subway) for underground systems.

### TRANSFORMER TYPE BY PROTECTIVE DEVICES

Completely Self-Protecting "CSP" Transformers have integrally-mounted lightning

arresters, and in addition have internally-mounted circuit breakers connected in series with the low-voltage winding, and protective links connected in series with the high-voltage winding. Therefore, no other auxiliary protective devices are required when operating these transformers.

Current-Protecting "CP" Transformers are equipped with the internally-mounted low-voltage circuit breaker and high-voltage protective links, but omit the lightning arresters. These transformers are used in locations where lightning is not a problem, so it follows that again no other auxiliary protective devices are required.

Surge-Protecting "SP" Transformers include integrally-mounted lightning arresters and internally-mounted high-voltage protective links, but omit the internally-mounted low-voltage circuit breaker. These transformers are used in locations where lightning is a problem. However, the protective links simply protect the system from outage due to internal transformer failure, so that if overload protection is desirable, it must be provided by external fuses.

Conventional "S" Transformers contain no protective equipment. Therefore lightning and over-current protection for these transformers must be provided by purchaser installed auxiliary protective devices.

### TRANSFORMER CONSTRUCTION

Unless specifically ordered otherwise, oil-immersed distribution transformers are constructed in conformance with current ASA, I.E.E.E., N.E.M.A., and E.E.I.-N.E.M.A. standards.

Single-Phase Transformers consists of a single core - coil assembly housed in either a round or rectangular tank.

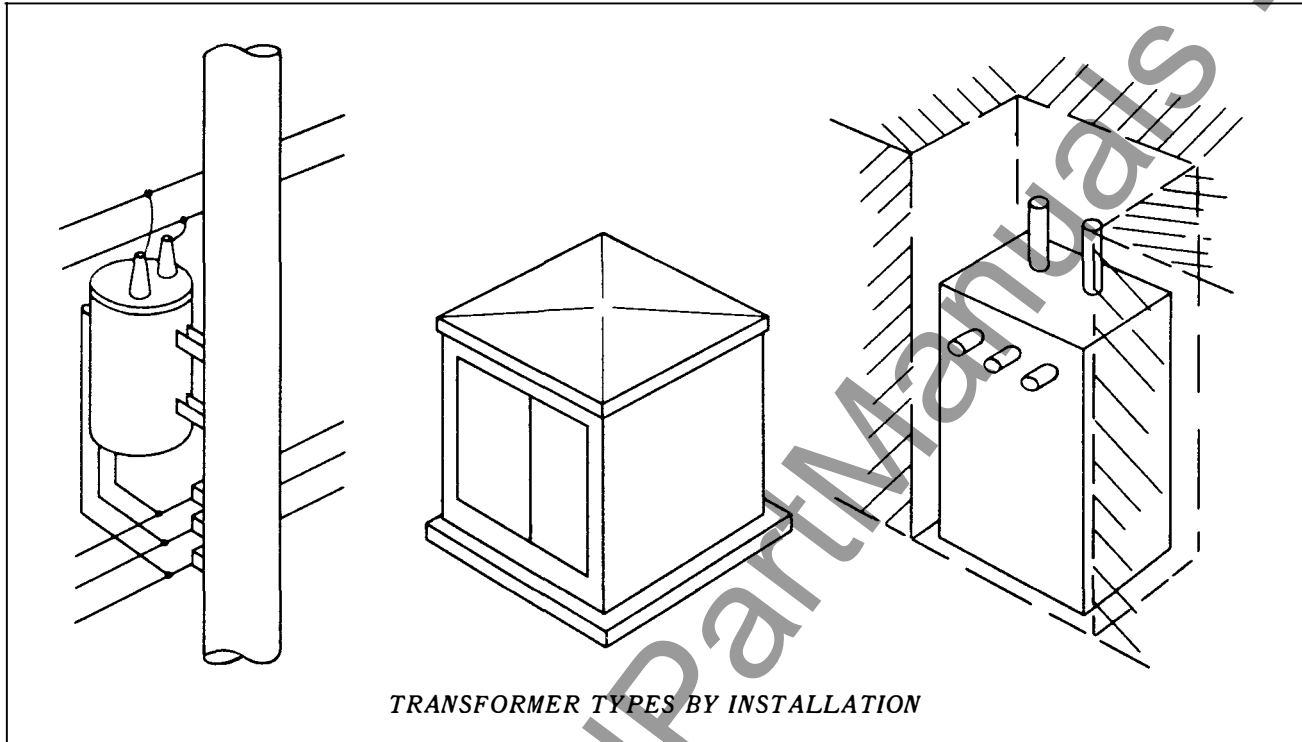

Fig. 1  
POLE-MOUNTED

Fig. 2  
PAD-MOUNTED

Fig. 3  
SUBWAY

Three-Phase Transformers are generally of the T-T or "Scott" connected construction, employing the use of two single-phase core - coil assemblies mounted in either a round or rectangular tank. Based on design and the purchaser's requirements, the core - coil assemblies can be mounted side-by-side or one above the other. Triplex three-phase transformers made from three single-phase core - coil assemblies, and other multi-phase transformers in duplex or single common core construction are manufactured to the purchaser's requirements.

#### TRANSFORMER BY CLASS

Class A are single-phase transformers with two fully-insulated high-voltage bushings.

Class B-1 are single-phase transformers with one fully-insulated high-voltage bushing and one neutral or partially-insulated high-voltage bushing. This type transformer is generally supplied so as to permit the purchaser to use either high-voltage bushing as the neutral bushing. (The arrester on a CSP transformer is also transferable.)

Class B-2 and B-3 are single-phase transformers with one fully-insulated high-voltage bushing, the other end of the high-voltage winding being grounded internally to the tank. The low-voltage winding is also grounded to the tank externally.

#### TRANSFORMER PROTECTIVE DEVICES

The major transformer protective devices are the internally-mounted circuit breaker,

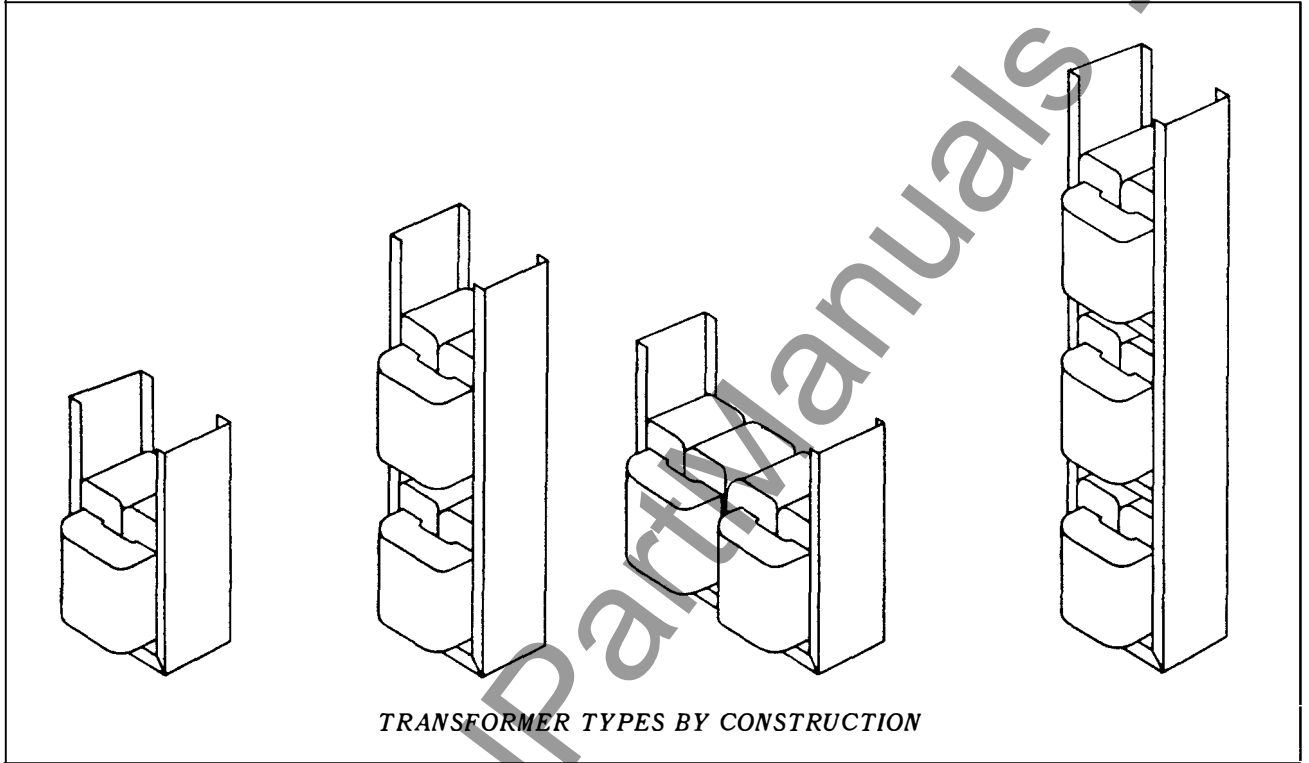

*Fig. 4*  
SINGLE-PHASE  
CORE & COIL

*Fig. 5*  
THREE-PHASE  
T-T DUPLEX

*Fig. 6*  
THREE-PHASE  
TRIPLEX

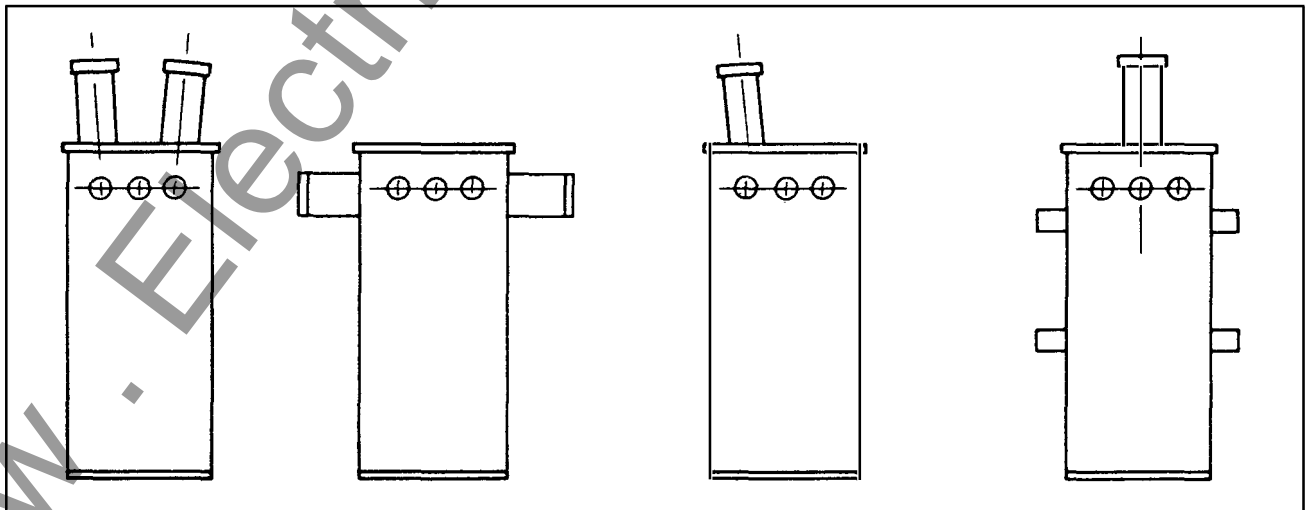

*Fig. 7*  
CLASS A

*Fig. 8*  
CLASS B2

*Fig. 9*  
CLASS B3

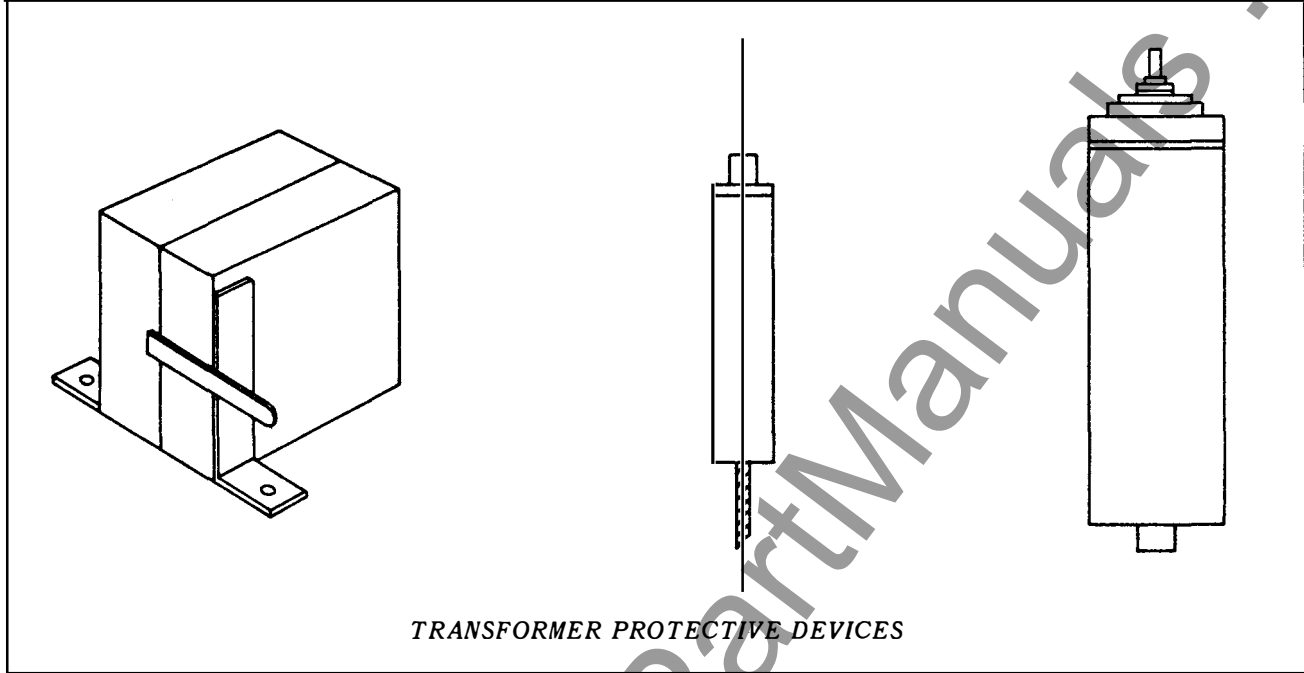

*Fig. 10*  
**CIRCUIT  
BREAKER**

*Fig. 11*  
**PROTECTIVE  
LINK**

*Fig. 12*  
**LIGHTNING  
ARRESTER**

the protective link, and the integrally-mounted lightning arrester.

The circuit breaker protects the transformer against secondary short circuits and abnormal overloads.

The protective link is designed to isolate the transformer from the system in case

of transformer fault and prevent system lockout.

The lightning arrester protects the transformer against dangerous over-voltages of all kinds whether they originate from lightning, switching surges or other transients.

www.ElectricalPartManuals.com

## Part Two: Installation

### RECEIVING, INSPECTION, HANDLING AND STORING

Oil-immersed distribution transformers are normally shipped completely assembled. (If ordered, pole hangers are shipped separately.) All transformers should be carefully inspected upon receipt and the transportation company notified of any damage.

The majority of the transformers are now shipped on a simple pallet, the transformer being securely attached to the pallet by means of metal straps banded over the transformer's lifting lugs. The palletized transformer may be moved readily, by lift truck, crane or cart. (NEVER LIFT OR DRAG ANY TRANSFORMER BY THE BUSHINGS OR ARRESTERS.)

No unusual precautions for storing need be taken because distribution transformers are normally built for outdoor service. Care must be exercised to prevent their being submerged in water (except "Subway" transformers).

Although Westinghouse takes every precaution to assure purchaser the transformers arrive at their destination in first-class condition, the purchaser should examine the exterior carefully for damage to porcelain insulators and arresters.

### PREPARATION FOR INSTALLATION

The purchaser should perform a final inspection of oil-immersed distribution transformers prior to installation.

### FINISH

The transformer is supplied with a high quality finish to withstand long outdoor ex-

posure service. However, in transformer shipping and handling, the finish may be scratched or abraded. The scratches and abrasions should be touched up with approved outdoor materials recommended by Westinghouse Electric Corporation.

### WEMCO CI OIL

The transformers are normally filled with dry de-gassed inhibited oil at the factory, after vacuum treatment of the core - coil assemblies in their own tanks. It is only by such a treatment that a high initial dielectric strength, comparable to that attained after long periods in service, can be obtained. Transformers must never be operated with the oil level more than 1/4" below the cold oil level mark. Should transformer oil have to be replenished, care must be taken that no moisture gets inside the transformer. Oil of normal dryness will test 22 Kv or higher in the standard test cap.

### MOISTURE

Transformer insulation's greatest enemy is moisture. Keep the transformer sealed at all times (except minimum inspection or adjustment periods) to avoid transference of moisture from the atmosphere to the transformer oil and from the oil to the transformer insulation. Care must be used in replacing the cover. If the gasket is not properly in place, and the cover not securely bolted, moisture in the form of rain or snow will be sucked into the tank.

### OPERATOR'S DATA

The purchaser's or operator's data may be attached to the transformer by using the space provided on the nameplate or on the

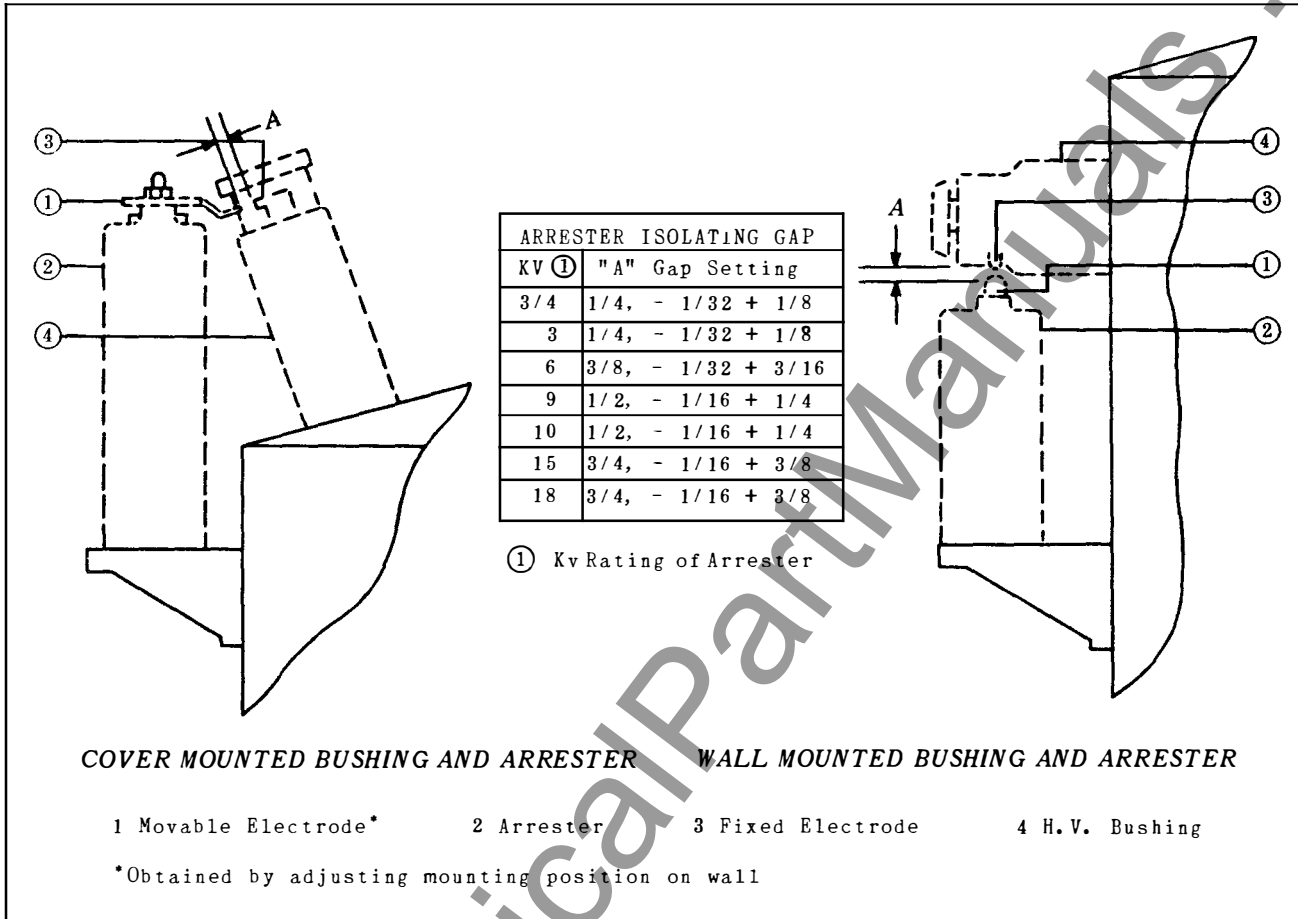

Fig. 13 LIGHTNING ARRESTERS AND GAP ADJUSTMENTS

pad below the nameplate. Holes in the pad may be tapped for #6-32 machine screws, or #4 self-tapping screws may be used. Screws shall be  $5/16 \pm 1/16$  inch long.

#### LIGHTNING ARRESTER GAP SETTINGS

For proper operation the external air gaps of lightning arresters should have spacings as shown in Fig. 13. The settings are made at the factory and normally require no adjustment, unless they may have been changed adversely due to tampering or damage in handling and shipping.

#### NAMEPLATE

If the transformer has multiple high-voltage or low-voltage ratings, refer to the diagram nameplate and connect the transformer or adjust the tap changer for the desired voltage prior to installation. THE TRANSFORMER MUST BE DE-ENERGIZED WHEN MAKING ADJUSTMENTS AND CHANGING CONNECTIONS.

#### PROTECTIVE LINK COORDINATION

"SP" and "CSP" transformers are provided with internally-mounted protective

links intended to fuse should a fault develop within the winding of the transformer. In order to limit the outage to a single transformer, it is important that any external fuses, circuit reclosers, or circuit breakers at branch lines or substations through which the transformer is fed be coordinated with the protective links. A more detailed discussion of the coordination of over-current devices is given in Westinghouse Transformer Technical Data Booklet No. 46-162. Current-time fusing characteristics of transformer protective links and system type T, K, and TU fuses is given in booklet No. 46-162A.

#### WINDING CONNECTIONS

Unless otherwise requested by the purchaser --

High-voltage windings having taps are connected when shipped for the rated voltage.

High-voltage windings of single-phase transformers designed for series-multiple operation (without external switch provision) are connected for the series voltage.

Transformers for series-multiple operation on the high-voltage side having externally-operated switches, are shipped connected for the lowest voltage, because it is assumed that this is the voltage at which they will be operated initially.

Low-voltage windings of single-phase transformers designed for both series-multiple and three-wire operation, where connections are made inside the tank, are connected for series or three-wire operation.

Three-phase transformers with low-voltage windings rated 240x480 volts shall be connected for 480 volts operation.

Three-phase transformers designed for both delta and wye operation on the high voltage side are normally shipped connected for the wye voltage.

Depending on individual circumstances, it may be desirable to change the connections or taps before mounting the transformer on the pole. For three-phase installations, it is important the connections (and taps) be alike on all three phases.

#### PARALLEL OPERATION

When transformers are banked in multiple along a line on different poles, the line drop will usually compensate for difference in impedance. However, transformers on the same pole are not usually operated in parallel, except in emergency, because the losses in the units will exceed the losses of a larger unit having a rating equal to their total. If transformers are so operated, the transformer having the lowest impedance will take more than its share of the load. Transformers are considered satisfactory for paralleling if their impedances are within 7.5 percent of the larger value for two-winding transformers or 10 percent for auto-transformers, providing, of course, their ratios are the same.

#### MOUNTING

Single-phase and three-phase pole-type transformers are provided with hanger lugs and may be mounted on poles, platforms, or pads, as desired. When platform or pad mounted, the hanger lugs may be used for bracing.

The simplest and most economical method of mounting, particularly for "CSP" transformers where no auxiliary equipment on the pole is necessary, is to bolt the transformer directly to the pole as shown in Fig. 14. Transformers above 100 Kva

## Part Three: Operation And Maintenance

### OPERATING LIMITS

Generally very little operating attention is required for oil-immersed distribution transformers, because there are no moving parts in the transformer proper. However, care should be used that the following major operating limits are not exceeded, or if exceeded, that sufficient compensation is provided elsewhere:

1. Frequency should not be appreciably lower than or greatly in excess of rating.
2. Voltage should not exceed rating by more than 5 percent while delivering continuous output or by more than 10% at no load.
3. Elevation at installation should not exceed 3300 feet (1000 meters) above sea level (unless the transformer was designed for this service).
4. Ambient temperature should not exceed 40 degrees C and the average temperature for any 24 hour period should not exceed 30 degrees C (unless the transformer is specifically designed for this service).
5. Continuous Kva load should not exceed rating (except for "CSP" transformers, in which case the circuit breaker will automatically allow loading up to full thermal capacity of the transformer, according to existing ambient temperature).
6. Continuous Kva load on reduced capacity taps should not exceed reduced capacity rating (except "CSP" transformers). Taps at voltages less than 90 percent of maximum voltage are usually rated at reduced Kva.
7. For transformers which do not have built-in lightning protection, suitable ex-

ternal protection should be provided since bushing flashover is not considered adequate protection against all forms of lightning.

### TAPS

**CAUTION:** To avoid danger to life and damage to property, connections must not be changed by either tap changers or terminal boards while the transformer is energized. These devices are not designed to change connections while carrying current. On three-phase installations, the voltage ratings of connections used should be the same for all three phases.

When the secondary voltage is too low, it may be raised by moving the tap changer on the primary side to a position having a lower rated voltage. The operating handle is above the oil level, and an indicator plate (with numerals corresponding to the position numbers on the diagram nameplate) is located just below the handle.

The positive snap action of the tap changer into position also guides the operator and insures a positive contact and a stop is provided to identify the highest and the lowest tap positions. Where a terminal board is furnished in lieu of a tap changer, similar results can be obtained by reconnecting in accordance with the connection diagram specified on the nameplate.

### CIRCUIT BREAKER MANUAL OPERATION

On all "CSP" or "CP" transformers, the circuit breaker may be opened to drop the secondary load or to disconnect the low-voltage windings of the transformer from the low-voltage bushings. This opening

is accomplished by moving the circuit breaker external operating handle located at the top of the tank wall from C toward R to its extreme position. Reclosing the breaker is accomplished by moving the handle back to its original C or closed position.

The circuit breaker external operating handle rotates in a quadrant or boss through the tank wall of the transformer. The mechanism is marked with letters C - L - O - R, indicating the direction of travel and the sequence of manual operations of the handle; that is, Close - Light reset - Open - Reset latches.

#### SIGNAL LIGHTS

On all "CSP" or "CP" transformers (except some 5 Kva ratings), the signal light furnishes a valuable service by indicating growing transformer overloads which could eventually cause breaker tripping. The signal light also indicates that point in the transformer loading at which it becomes more economical to install the next larger Kva rating transformer, than to further overload the existing transformer.

Whenever a signal light is observed, it is common practice to reset the light at least once to determine whether its operation was caused by an isolated load condition or whether it was caused by a repetitive condition. The signal light may be reset without disconnecting the secondary load by moving the external operating handle to the L (light reset) position and moving it back to the C or close position. If the light is immediately relighted, the overload is either still continuing or has occurred so recently that the transformer has not yet cooled down. If the light is relighted within a few days, this is an indication of a recurrent overload.

#### CIRCUIT BREAKER TRIPPING

In most cases, if the signal light warning is not heeded, or if the overload is extreme, the circuit breaker may trip open to prevent the winding from burning out. Since this will disconnect the load entirely, the transformer will usually have cooled sufficiently by the time the troubleman arrives that the breaker can be reclosed to restore service at least temporarily. If the oil temperature is still high, the signal light may continue to burn after the breaker has been reset. If the load is still excessive, the circuit breaker may again trip open to protect the winding against burnout.

**IMPORTANT:** On transformers which have two circuit breakers, both breakers must be closed to secure full transformer capacity.

#### CIRCUIT BREAKER EMERGENCY CONTROL

Following a circuit breaker tripout due to a long, sustained overload condition, the transformer oil may not have had time to cool sufficiently to allow the breaker latch to be reset immediately, therefore making it impossible to reclose the breaker.

On all "CSP" and "CP" transformers (except some 5 Kva and ratings 167 Kva and above), an Emergency Control Lever, located above the breaker operating handle, is provided to recalibrate the breaker to a higher trip temperature and thus allow immediate breaker reclosing. The Emergency Control Lever, held in its normal or N position by a meter seal, acts to increase the breaker trip temperature when it is pulled downward to the emergency or E position by hand or by a hookstick. The meter seal is designed to slip upon the application of a downward force to the

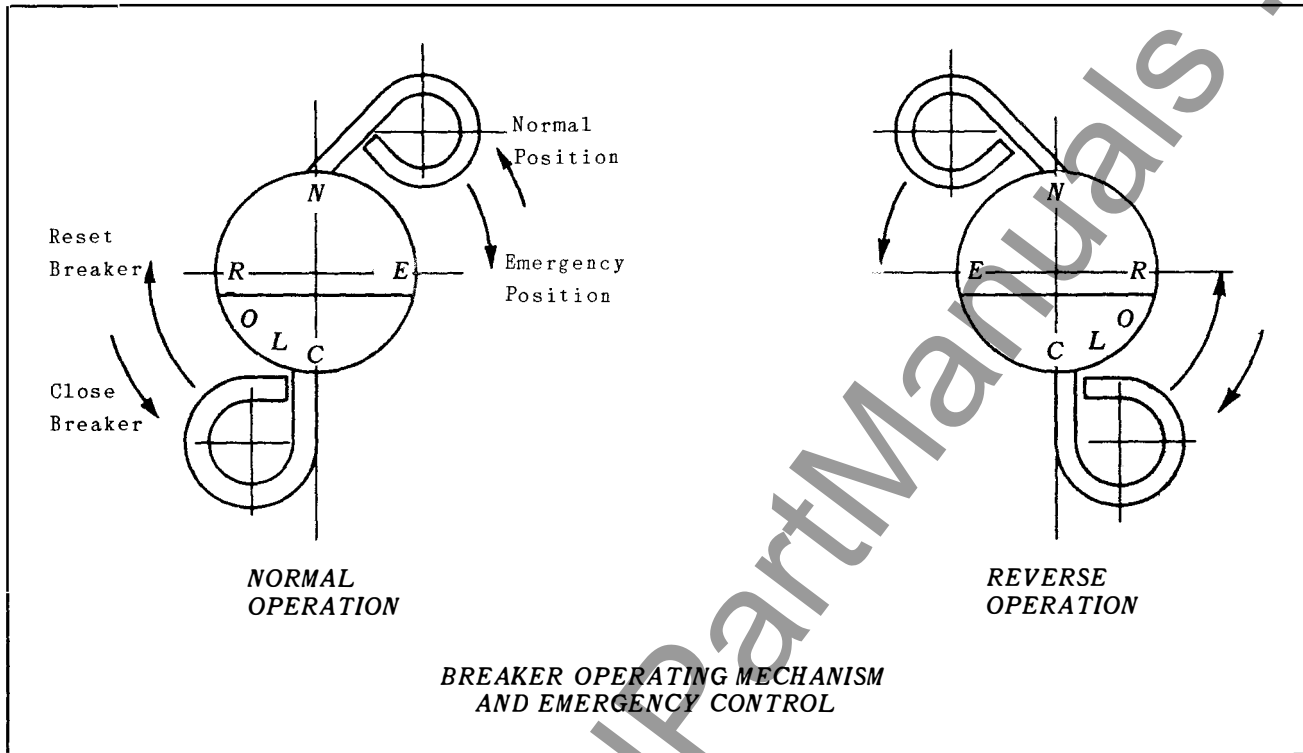

Fig. 15

Emergency Control Lever, so it need not be removed completely.

In general, it is desirable to return the Emergency Control Lever to its upward or "Normal" position within a day or two after its use. Extended use of the Emergency Trip Setting of the breaker will result in higher winding temperatures before the breaker trips with subsequent reduction in transformer life.

#### PRECAUTIONS

1. When a transformer is disconnected from the line, make certain the lines from the transformer to the open disconnects or open breaker are grounded. Make certain there can be no backfeed, the transformer is de-energized and cannot be re-energized while you are working on it.
2. If it is necessary to remove the cover when working on a transformer, great care should be taken to prevent loose articles from falling into the tank, since these materials if allowed to remain may cause a breakdown.
3. Treat all wires and testing equipment as energized and capable of severe shock.
4. Work safely. All safety rules of the purchaser should be followed.
5. Use only approved fire extinguishers such as CO<sub>2</sub> and Pyrene for electrical equipment fires.
6. Never operate or change positions on tap changers, terminal blocks and switches (designed for changes during de-energized periods) while the transformer is energized.

7. Never operate or apply voltage to transformers with oil below the proper level.

8. Transformers should be protected from excessive overloads and faults due to lightning surges, and short circuits with approved protective devices. ("CSP" transformers are totally protected and therefore require no additional protective devices.)

9. Make sure lightning arresters have the proper external gap settings prior to energizing the transformers.

10. Carefully check the nameplate for the rating and proper designated connection of the transformer to the system.

11. Never lift or drag any transformer by the bushings or arresters.

12. Don't expose the inside of a transformer to the atmosphere over an extended period of time. Keep it sealed tight, except when inspecting, changing connections or making minor repairs. This should be done as quickly as possible.

#### OTHER INFORMATION

Complete instructions covering detailed description of construction, application, operation and maintenance of oil-immersed distribution transformers and all accessories can be obtained through your nearest Westinghouse representative.

#### MAINTENANCE

Because of the comparatively small investment involved at each location and because of the generally high level of reliability, very little inspection or maintenance is economically justified for the great majority of distribution transformers. A vis-

ual inspection of the external parts of the transformer is desirable at perhaps two to five-year intervals based on local operating conditions and experience. At such times the general condition of the following should be noted:

1. High-voltage bushings and leads.
2. Low-voltage bushings and leads.
3. Lightning arresters and porcelains.
4. Finish on tank.
5. Transformer gasket seals.

Where parts have become broken or where the tank shows evidence of excessive rusting, the transformer should be repaired.

When transformers are returned to a service shop for any reason, it is common practice to make a thorough inspection of all parts, and make any additional repairs which may be indicated, including the repainting of at least the exterior surfaces of the tank. Gasket seals of the transformer should also be checked at this time. If there is any evidence of moisture having entered the unit, the oil should be drained, the core and coil assembly thoroughly dried, and the unit then refilled with new inhibited "Wemco CI" oil. Vacuum treat the transformer after refilling to insure maximum electrical strength. Whether or not the oil is replaced, the level should be brought to the proper height, as indicated by the oil gauge (if any) or by the oil level mark on the inside of the tank.

**CAUTION:** If the transformer is tested either before or after the repair operations, the test voltage used should not exceed 65 percent of the factory test values. See N.E.M.A. Transformer Standard 48-132.

## RENEWAL PARTS

Maintenance and repair work on distribution transformers is usually done in a shop after a replacement unit has been installed to continue service. It is, therefore, not usually necessary that spare parts be carried to meet emergency conditions, but only from a repair shop "convenience" standpoint. Stocking practice varies widely with different operators. It sometimes depends on how many units are in service with like

parts. Most operators limit their renewal parts stock to bushings, terminal boards, tap changers and in some case (for "SP" and "CSP" transformers) lightning arresters. Some operators carry practically no renewal parts but order them when required for a specific case.

Renewal parts information for Westinghouse transformers is available upon request.



[www.ElectricalPartManuals.com](http://www.ElectricalPartManuals.com)