

**Instructions for Handling
Silicone Insulating Fluid
P.D.S. 53846 BE
and
Installation and Maintenance
of Silicone Transformers**



Westinghouse Electric Corporation

SMALL POWER TRANSFORMER DIVISION, SOUTH BOSTON, VIRGINIA
MEDIUM POWER TRANSFORMER DIVISION, SHARON, PENNSYLVANIA

I.B. 45-063-102B Effective November, 1978 Supersedes I.B. 45-063-102A, July 1978

CONTENTS

	Page
PART ONE -- SILICONE DIELECTRIC INSULATING FLUID	3
Characteristics	3
Advantages	3
Specific Characteristics	3
Environmental Considerations	3
Storage	4
Sampling Silicone Fluid from Shipping Containers	4
Sample Bottle	4
Thieves for Sampling	4
Procedure	5
Quantity of Sample	6
Sampling Silicone Fluid from Apparatus	6
Periodic Inspection	7
Checking Silicone Fluid Level	7
Checking Dielectric Strength	7
Westinghouse Testing Service for Silicone Fluid	7
Testing Methods	7
Dielectric Strength Test	7
Apparatus	7
Procedure	8
Tests	9
Report	9
Neutralization Test	9
Solutions Required	9
Procedure	9
Calculations	9
 PART TWO -- INSTALLATION AND MAINTENANCE OF SILICONE FLUID TRANSFORMERS	10
Installation	10
Inspection	10
Accessories and Fittings	11
Finish	11
Filling	12
Filling Under Vacuum	12
Placing in Service	12
Pressure Testing	12
High Altitude	13
Grounding Transformer Tank	13
Grounding Low Voltage Winding	13
Making Connections	13
Voltage Application	13
Inspection	13

All possible contingencies which may arise during installation, operation, or maintenance, and all details and variations of this equipment do not purport to be covered by these instructions. If further information is desired by purchaser regarding his particular installation, operation or maintenance of his equipment, the local Westinghouse Electric Corporation representative should be contacted.

Part I – Silicone Dielectric Insulating Fluid

NOTE: To date, none of the available substitutes for polychlorinated biphenyls (PCB's) have equal or equivalent liquid non-flammability characteristics of PCB's. In addition, under certain fault conditions it is possible to generate gaseous by-products, hydrogen being one of these; from any hydrocarbon oil or silicone. If tank rupture were to occur in the presence of oxygen, fire could result from the gaseous products being produced by the arc, provided an ignition source is present.

CHARACTERISTICS

The silicone fluid is a low viscosity dimethyl siloxane polymer. Dimethyl silicone, as a transformer dielectric insulating fluid, has been used for several years in some special transformer applications.

Dimethyl silicone offers the properties of good dielectric characteristics, high temperature stability, good compatibility with solid insulating materials, and low toxicity.

Dimethyl silicone has dielectric strength comparable with mineral transformer oil and INERTEEN®. Care must be exercised in handling and testing to keep the material clean and free of moisture. It is not affected by the reaction with other materials of transformer construction and is non-oxidizing and non-corrosive at temperatures considerably above normal operating temperatures.

Dimethyl silicone is non-toxic to aquatic, bird, animal, and human life. It has a higher flash point than mineral oil and INERTEEN, and even though it will burn, it is self-extinguishing.

Advantages

1. High dielectric strength.
2. High temperature stability.
3. Good compatibility with other materials.
4. Low pour point.
5. Low toxicity.

Specific Characteristics of Silicone Insulating Fluid

1. Dielectric strength, kV min.: 32
2. Power factor, % 60 HZ, 25°C max.: .01
3. Interfacial tension, dynes/cm min.: 35
4. Neutralization number, mg KOH/g max.: .01
5. Color max.: 0.0
6. Kinematic viscosity-Centistokes (CS)
 - @ 25°C (77°F) 47.5-52.5
 - @ 40°C (104°F) 36.5-41.5
7. Specific gravity: .957-.963
8. Pour point, °F max.: -67
9. Moisture, PPM max.: 50
10. Flash point, °F min: 545
11. Fire point, °F min.: 650
12. Specific heat, cal/g °C: .360
13. Coefficient of expansion cc/cc °C: .00104
14. Dielectric constant: 2.5
15. Weight per gallon, lbs.: 8.0

ENVIRONMENTAL CONSIDERATIONS

While dimethyl silicone is nonbiodegradable, it does not bioaccumulate and is non-toxic. Silicone fluid has earned a reputation for low toxicity and

physiological inertness. Numerous toxicological studies* have placed silicones among the least toxic of all industrial chemicals. As a result, specific grades of silicone conform to appropriate FDA regulations to permit direct and indirect food contact under specified conditions in such uses as defoaming, and in cosmetics and pharmaceutical applications.

No adverse reactions on human or animal life have been discovered in testing.* Test results include:

1. Skin: no response
2. Eyes: may cause temporary discomfort
3. Inhalation: minimal toxicity
4. Oral: essentially non-toxic

Recent studies* on fish and bird life indicate no adverse effects or any evidence of bioconcentration. Tests include:

1. Acute daphnia studies
2. Acute toxicity in sunfish and rainbow trout
3. Bioaccumulation in sunfish
4. Acute toxicity in shore crabs, shrimp, and cockles
5. Sub-acute toxicity in ducks and quail
6. Reproductive and residue studies in chickens

STORAGE

Silicone fluid is shipped in tank cars, drums, or cans. Drums or cans of silicone fluid should be stored in a covered area and when stored out-of-doors, the bungs should be down to prevent collection of water around the bung. A storage tank should be mounted on piers above the ground and accessible to all points for inspection for leakage. There should be a curb on the ground around the tank to contain any spillage or leakage.

*Tests conducted by Dow Corning Corporation.

It is desirable, if possible, to keep silicone fluid in storage at a temperature slightly above ambient to prevent moisture condensation.

SAMPLING SILICONE FLUID FROM SHIPPING CONTAINERS

The dielectric strength of silicone fluid is affected by the most minute traces of certain impurities, particularly water. It is important that the greatest care be taken in obtaining the samples and in handling them to avoid contamination. There have been low dielectric test results reported from the field which, upon investigation, have been found to have been largely a matter of carelessness in handling. The following instructions, based on the specifications of the American Society for Testing Materials, must be followed to assure accurate results.

Sample Bottle. The sample container shall be made of glass, of at least 16 oz. capacity, and shall be cleaned and dried. The glass bottle is preferable to a metal container as it may be examined to see if it is clean. It also allows visual inspection of the silicone fluid before testing, particularly as regards free water and solid impurities.

The clean, dry bottle shall be thoroughly rinsed with Stoddard solvent or other suitable solvent which has previously withstood a dielectric test of at least 25 kv in a standard test cup, and shall be allowed to drain. It is preferable to heat the bottle and cap to a temperature of 100°C (212°F) for one hour after thoroughly draining. The bottle shall then be tightly capped and the neck of the bottle dipped in melted paraffin.

IMPORTANT: Glass jars having rubber gaskets or stoppers must not be used. Silicone fluid may easily become contaminated from the sulfur in natural rubber.

Thieves for Sampling. A convenient and simple thief for use with 55 gal. drums may be made of metal as follows: Length 36 in., diameter 1-1/4 in. with cone shaped caps over the ends and openings at the ends 3/8 in. in diameter. Three legs equally spaced around the thief at the bottom, and long enough to hold the opening 1/8 in. from the bottom of the container being

sampled, aid in securing a good representative sample. Two rings soldered to the opposite sides of the tube at the outer end will be found convenient for holding the thief by slipping two fingers through them and leaving the thumb free to close the opening. In an emergency, a piece of glass tubing 36 in. long may be used. For the tank cars, a thief employing a trap at the bottom may be used.

ment at a temperature not less than 37.8°C (100°F), and shall be stored in a vertical position in a rack having a suitable drainage receptacle at the base.

Samples shall not be drawn from containers indoors until the silicone fluid is at least as warm as the surrounding air. Cold silicone fluid may condense enough moisture on the surface from a humid atmosphere to seriously affect its insulating properties. Sampling silicone fluid from containers out of doors is undesirable, due to the possibility of condensation of moisture, and should be avoided whenever possible. (Samples should never be taken in the rain.)

Procedure. The drums to be sampled shall be assembled in line, with bungs up, and numbered. The bungs shall be unsealed and removed and laid with the oily side up beside the bungholes. The unstoppered sampling receptacle can be placed on the opposite side of the bungholes. The top hole of the thief shall be closed with the thumb, the thief quickly thrust to the bottom of the container and the thumb removed. When the thief is filled, the thumb shall be replaced, the thief quickly withdrawn and the contents allowed to flow into the sampling receptacle. The lower holes shall not be closed with the fingers of the other hand. The free hand shall not be used to guide the stream of silicone fluid except by touching the thief, and this only when necessary. The silicone fluid shall not be allowed to flow over the hand or fingers before it flows into the sampling receptacle.

When the sampling receptacle is filled, it shall be closed quickly and the bung replaced in the container and tightened. The sampling receptacle shall be taken under cover to the testing laboratory as quickly as feasible.

After using, thoroughly clean all thieves and sampling receptacles as outlined above.

The tank cars of silicone fluid shall be sampled by introducing the thief through the manhole on top of the car, the cover of which shall be removed carefully so as not to contaminate the silicone fluid with dirt. The sample shall be taken as near as possible to the bottom of the tank car. This shall not be done while rain or snow is falling.

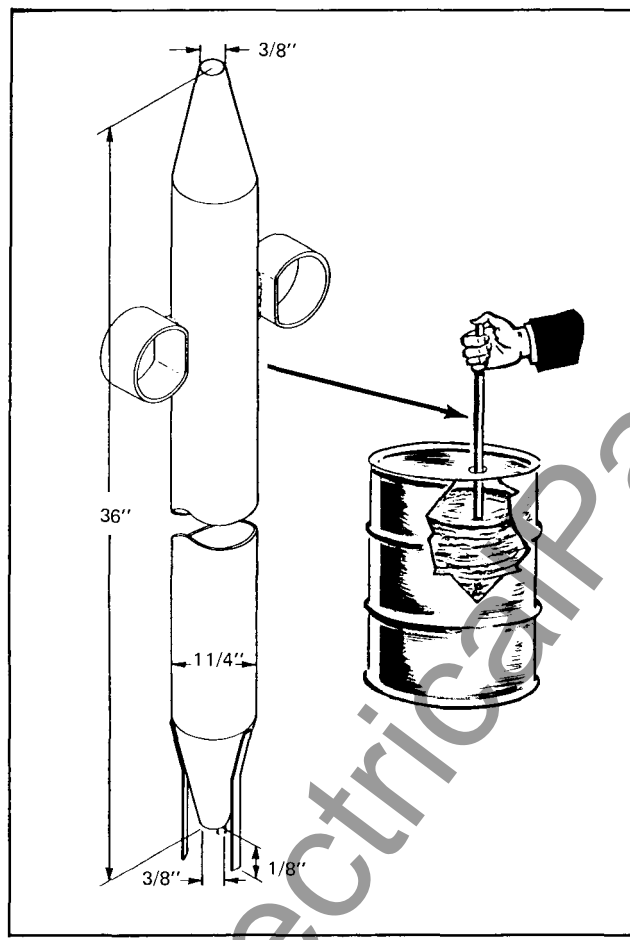

Fig. 1 Drum Thief and Method of Sampling

The thief shall be suitable for reaching the bottom of the container and the sample shall be taken with the thief not more than about 1/8 in. from the bottom.

Thieves should be cleaned before and after use by rinsing with Stoddard solvent or other suitable solvent; be sure that no lint or other fibrous material remains on them. When not in use, they should be kept in a hot, dry cabinet or compart-

When separate samples are being taken from a consignment or part of a consignment, care should be exercised to prevent contaminating the samples. A separate thief shall be used for each sample or the thief previously used shall be well drained and then thoroughly washed with silicone fluid from the next container to be sampled; the silicone fluid thus used for washing should be thrown away before the next sample is taken. (Enough thieves shall be provided to insure thorough drainage of each thief after rinsing with silicone fluid to be sampled before using it to withdraw the actual sample.) For obtaining only a few samples, two thieves are sufficient, but for obtaining a large number of samples (for example sampling a carload of drummed silicone fluid) six or more thieves desirable.

When one average sample of a consignment or batch is being taken, the same thief may be used throughout the sampling operation, and it is not necessary to rinse the thief with silicone fluid before taking any of the portions that go to make up the total average sample.

Quantity of Sample. It is recommended that one 16 oz. bottle of silicone fluid be taken as a sample for dielectric tests, and a one quart sample be taken when complete physical and chemical tests are to be made. At least one sample should be taken from a tank car of silicone fluid. One sample may be taken from each drum, or if desired, a composite sample may be made from silicone fluid from five drums, provided all of the drums are airtight. When the bung is first loosened, a hissing sound should be heard, which indicates that the drum has been airtight. If the test of the composite sample is not satisfactory, a sample from each of the drums represented should be tested.

When drums have been stored exposed to the weather, a sample from each drum shall be tested. The sample of silicone fluid should be examined for free water, and if any is noted, the drum of silicone fluid should be put through a blotter filter press and resampled for dielectric strength.

If the sample is being taken from a tank car, and water appears, follow the same procedure.

SAMPLING SILICONE FLUID FROM APPARATUS

When taking samples of silicone fluid from apparatus in which a thief cannot be used, use the sampling valve and follow the procedure outlined above as far as practicable.

Care should be taken to procure a sample which fairly represents the silicone fluid at the bottom of the tank. A sufficient amount of silicone fluid should therefore be drawn off before the sample is taken, to insure that the sample will not be that which was stored in the sampling pipe. For this reason, the valve and the drain pipe should be sufficiently small to be emptied with convenience and yet sufficiently large to give an even flow of silicone fluid and avoid clogging by sediment. A 1/4 in. pipe and valve is recommended. This, of course, may be separate from the drainage pipe and valve or it may be connected to the drainage valve by means of a suitable reducer.

It is of utmost importance that the sample of insulating silicone fluid represents the actual condition of the silicone fluid in the apparatus. Every precaution should be taken to keep the sample and container free from foreign impurities or moisture.

If the apparatus is installed outdoors, care should be taken to prevent contamination of the sample by rain, snow, etc.

A glass bottle is recommended as a sampling receptacle, so that any water present may readily be seen.

If the sample contains free water, it is not suitable for dielectric test and the sample and bottle should be discarded. A second sample should be taken after at least two quarts of silicone fluid have been withdrawn. If free water still exists in the sample, the silicone fluid in the apparatus should be put through a blotter filter press and resampled for dielectric strength.

In order to make sure that the dielectric strength is up to its proper value, the insulating silicone fluid in any piece of apparatus should be tested before its initial operation, and at regular intervals thereafter.

Periodic Inspection. Silicone fluid may deteriorate in service even under what seems to be the most favorable conditions. The more handling an insulating silicone fluid receives, the greater the opportunity for contamination unless adequate precautions are taken.

IMPORTANT: It is essential to provide for periodic inspection and test, and to purify the silicone fluid whenever necessary in order to maintain it in good condition.

The frequency of inspecting and testing depends upon the service to which the silicone fluid is subjected, and the construction of and the materials used in the apparatus.

The silicone fluid transformers which are operated under extremely heavy loads requires more frequent inspection than that in normal or light service.

It is recommended that operators prepare a schedule for inspection based on the operating conditions. Reference to the station log, together with the record of dielectric tests of the silicone fluid should determine the frequency of inspection and test. The period between successive inspections should not be longer than six months or until experience indicated that the time between tests can be extended. If the dielectric strength of the silicone fluid drops below 22 kv in the standard dielectric test the silicone fluid should be blotter pressed. In the event that the dielectric strength is not readily restored to 26 kv or above, other tests should be made to determine if the silicone fluid should be reconditioned or replaced.

Checking Silicone Fluid Level. It is essential that the proper silicone fluid level be maintained. Low silicone fluid level may cause breakdown of insulation or flashover of bushing in any apparatus.

Checking Dielectric Strength. The silicone fluid should be tested regularly for dielectric strength and purified when the tests show need of it. The testing should be systematized and complete records kept.

WESTINGHOUSE TESTING SERVICE OF SILICONE FLUID

Many users of transformers do not have the necessary facilities for testing insulating silicone fluid.

This service consists of an examination of the silicone fluid by a competent chemist. Recommendations will be made as to the suitability of the silicone fluid for continued use, whether it would be desirable and economical to clean it, and in a general way, the preferred method of cleaning. In submitting samples for this service, the history of the silicone fluid represented should be given as completely as possible. Samples should not be less than one pint.

Other tests available include a complete Physical and Chemical Examination and a power factor test.

The Physical and Chemical Examination encompasses tests of acid and base numbers, color, interfacial tension test, pour point, specific gravity, and viscosity.

A combination is offered of the dielectric test, the acid and base number test, the interfacial tension test, and the power factor test. This combination covers those tests most often requested for general purposes. (For further details on available tests, refer to the nearest Westinghouse Office or contact Materials and Manufacturing Technology Department, Westinghouse Electric Corporation, Sharon, Pennsylvania).

TESTING METHODS

Dielectric Strength Test

Apparatus. (See Fig. 2) The transformer and the source of supply of energy shall not be less than 1/2 KVA, and the frequency shall not exceed 100 cycles per second.

The rate of rise shall approximate 3000 volts per second. The voltage may be measured by any approved method which gives root-mean-square values.

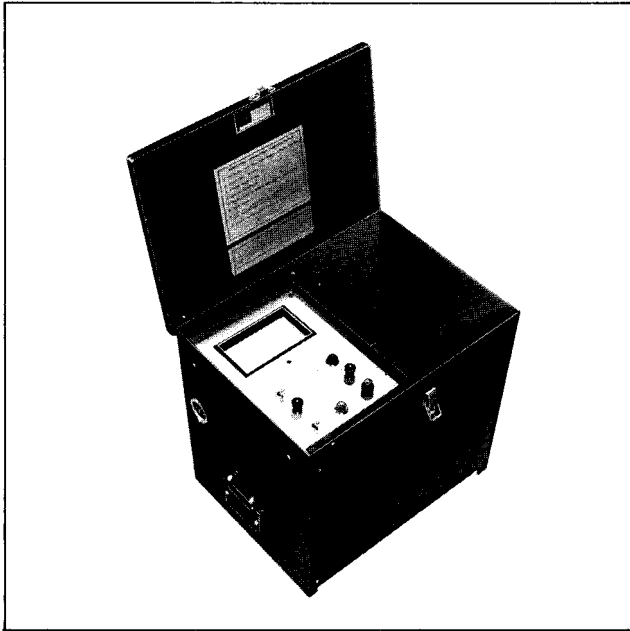

Fig. 2 Portable Dielectric Tester (Model OC-50)

The test cup for holding the sample of silicone fluid shall be made of a material having a suitable dielectric strength. It must be insoluble in and unattacked by silicone fluid and gasoline, and nonabsorbent as far as moisture, silicone fluid, and gasoline are concerned.

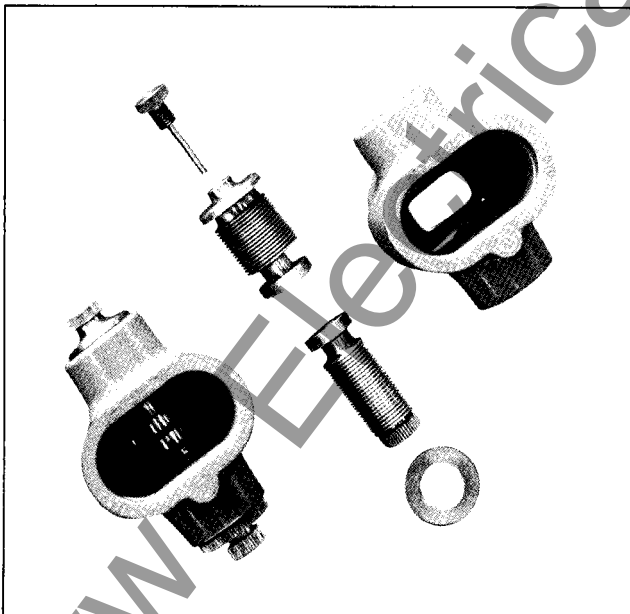

Fig. 3 Oil or Fluid Test Cup for Dielectric Test (ASTM-D-877)

The electrodes in the test cup between which the sample is tested shall be circular discs of polished brass or copper, 1 in. in diameter, with square edges. The electrodes shall be mounted in the test cup with their axes horizontal and coincident, with a gap of 0.100 in. between their adjacent faces, and with tops of electrodes about 1-1/4 in. below the top of the cup.

Procedure. The spacing of electrodes shall be checked with a standard round gauge having a diameter of 0.100 in., and the electrodes then locked in position.

The electrodes and the test cup shall be wiped clean with dry, calendered tissue paper or with a clean, dry chamois skin and thoroughly rinsed with a Stoddard solvent or other suitable solvent until they are entirely free from fibres.

The test cup shall be filled with dry toluene and voltage applied with uniform increase at the rate of approximately 3000 volts (rms) per second until breakdown occurs. If the dielectric strength is not less than 25 kv, the cup shall be considered in suitable condition for testing the silicone fluid. If a lower test value is obtained the cup shall be cleaned with solvent and the test repeated.

NOTE: Evaporation of solvent from the electrodes may chill them sufficiently to cause moisture to condense on their surface. For this reason, after the final rinsing with solvent, the test cup should be immediately filled with the silicone fluid which is being tested, and the test made at once, or the electrodes should be thoroughly dried before using.

The temperature of the test cup and of the silicone fluid when tested shall be the same as that of the room, which should be between 20 and 30°C (68 and 86°F). Testing at lower temperatures is likely to give variable results which may be misleading.

The sample in the container shall be agitated with a swirling motion, to avoid introducing air, so as to mix the silicone fluid thoroughly before filling the test cup. This is even more important with used silicone fluid than with new as the

impurities may settle to the bottom and the test may be misleading.

The cup shall be filled with silicone fluid to a height of no less than 0.79 in. (20 mm) above the top of the electrodes.

The silicone fluid shall be gently agitated by rocking the cup and allowing it to stand in the cup for three minutes before testing. This will allow air bubbles to escape.

Voltages shall be applied and increased uniformly at a rate of approximately 3000 volts (rms) per second until breakdown occurs as indicated by a continuous discharge across the gap. (Occasional momentary discharges which do not result in a permanent arc may occur; these should be disregarded).

Tests

a. Only one breakdown test may be made on silicone fluid per cup filling. The cup must be thoroughly cleaned between tests. When five individual tests are run, two or more cups should be used. If the average deviation from the mean exceeds 10 percent or if any individual test deviates more than 25 percent from the average, additional tests shall be made. The dielectric strength shall be determined by averaging the first five tests that conform to the allowable variations.

b. When silicone fluid is tested in considerable quantity, so that the time required for testing is excessive and when it is merely desired to determine whether the breakdown safely exceeds the limit specified or in those cases where the amount of silicone fluid available for test may be very limited, one breakdown test shall be made per cup filling. The cup should be thoroughly cleaned before the second test is run. If neither breakdown is below the specified value, the silicone fluid may be considered satisfactory and no further tests shall be required. If either of the breakdowns is less than the specified value, a breakdown shall be made on three additional fillings and test results analyzed in accordance with (a). (Keep in mind the thorough cleaning of test cell between runs).

Report. The report shall include the volts (rms value) at each puncture, the average voltage for the two or five individual fillings, grand average voltage, and the approximate temperature of the silicone fluid at the time of the test.

Neutralization Test

The Neutralization Number is the weight in milligrams of potassium hydroxide required to neutralize the acid in one gram of silicone fluid.

Solutions Required

a. **Standard Potassium Hydroxide Solution** (alcoholic, 0.1 N) – add 6 g. of c.p. solid KOH to 1 liter of c.p. anhydrous isopropyl alcohol. Boil, add 2 g. of c.p. Ba (OH)₂ and boil again. Cool, filter, and store in a chemically resistant bottle protected by a guard tube containing soda lime and soda asbestos (Ascarite). Standardize against pure potassium acid phthalate using phenolphthalein as an indicator.

b. **Titration Solvents** - Add 500 ml. of c.p. toluene and 5 ml. of water to 495 ml. of c.p. anhydrous isopropyl alcohol.

c. **Alpha-Naphtholbenzein Indicator Solution** – Prepare a solution containing 10 g. of alpha-naphtholbenzein per liter of c.p. anhydrous isopropyl alcohol.

Procedure. Into a 250 ml. Erlenmeyer flask introduce 40 g. silicone fluid weighed to nearest 0.1 gram. Add 100 ml. of the titration solvent and 3 ml. of the indicator solution. Titrate immediately at a temperature below 30°C. Consider the end point definite if the color change to green persists of 15 seconds. A blank shall be determined on the solvent.

Calculations. The neutralization number of mg

$$\text{KOH per g. of silicone fluid} = \frac{(A-B) (N) \times 56.1}{W}$$

- A = ml. KOH solution required for sample.
- B = ml. KOH solution required for blank.
- C = normality of KOH solution.
- W = grams of sample used.

Part II—Installation and Maintenance of Silicone Fluid Transformers

NOTE: To date, none of the available substitutes for polychlorinated biphenyls (PCB's) have equal or equivalent liquid nonflammability characteristics of PCB's. In addition, under certain fault conditions it is possible to generate gaseous by-products, hydrogen being one of these; from any hydrocarbon oil or silicone. If tank rupture were to occur in the presence of oxygen, fire could result from the gaseous products being produced by the arc, provided an ignition source is present.

INSTALLATION

For convenience in handling, all transformers are equipped with lugs or eyes for lifting and moving the complete assembly filled with silicone fluid by use of a crane. Additional means are provided for the heavier parts such as covers, core and coils, radiators and terminal chambers. Jacking and lugs are supplied on either the base or corners or the tank. A transformer should only be lifted or moved by jacks placed against these lugs and not against the cooling tubes, radiator valves, or other fittings.

An indoor installation requires that the room in which the transformers are placed must be well ventilated so that the heated air can readily escape and be replaced by cooler air from the outside. If the room is poorly ventilated, this exchange of air takes place too slowly and the temperature of the air in the room may become excessively high. At any given load the temperature rise of a self-cooled transformer will be a fixed number of degrees above the temperature of the surrounding air. The temperature of the transformer is the sum of this rise and the air temperature; therefore, care must be taken to provide a room sufficiently ventilated to permit operation of transformers at a reasonable temperature. Area of the air inlets should be such that the ambient temperature never exceeds 40°C (104°F) with an average over twenty-four hours not exceeding 30°C (86°F); 50 to 60 square feet per 1000 kva of transformer capacity has been satisfactory. Outlet openings with the same total area should be provided.

CAUTION: Because of the gaseous by-products that can be generated during a fault condition, hydrogen being one of these, it is recommended that indoor units be vented to the outside. Venting adapters are provided on all indoor units for this purpose.

Self-cooled transformers should always be well separated from one another and from adjacent walls, partitions, etc., in order to permit free air circulation about the cases. This separation should not be less than 24 to 36 inches depending on the size of the units.

INSPECTION

All silicone fluid transformers are carefully inspected and tested at the factory and they are in good condition when shipped; but it is desirable to inspect each transformer thoroughly before placing it in service.

When a transformer is shipped complete and filled with silicone fluid, this inspection should include a check of the silicone fluid level, the tightening or adjustment of any parts that may have become loose or out of place, and determining the extent to which moisture may have entered the transformer. The latter can best be determined from the dielectric strength of the silicone fluid. Silicone fluid used for filling transformers should have a dielectric strength of 30 KV or higher. When it tests less than this, the silicone fluid should be filtered. If the dielectric strength is very low or if there is any other evidence of moisture, it is necessary to dry the transformer.

Silicone fluid transformers should be dried by the short circuit method with the transformer immersed in the silicone fluid and with the tank sealed tightly. During the drying out operation, the silicone fluid should be circulated through a filter press or preferably through a silicone fluid conditioner. A filter press will remove dirt and most of the moisture, but the conditioner will remove these and other contaminating materials as well.

CAUTION: Flowing silicone fluid can develop significant static charge. Equipment subjected to moving streams of silicone fluid, pump lines, filter presses, tanks, etc. should be grounded. Because of the slow conduction through silicone fluid, these grounds should be maintained for at least an hour after flow has been stopped. The potential for arcs from the moving fluid surface, even if grounded, requires that any explosive or highly flammable gases be removed from any containers in which these static charge conditions may exist before pumping silicone into these containers.

The desired load current should be obtained by short circuiting one winding and impressing the proper impedance voltage on the other winding. The full load impedance may usually be found on the instruction plate for the transformers; if the impedance of the transformer is not known, it should be requested from the Westinghouse Electric Corporation, South Boston, Virginia or Sharon, Pennsylvania by identifying the transformer with its serial number.

If the transformer is at or lower than room temperature at the start of the drying process, circulation of 125 to 150% of full load current will hasten the heating, and a higher top silicone fluid temperature can be obtained more quickly by blanketing the coolers when tubular coolers are used or by shutting off the radiator valves when radiators are used. The cover should be lagged to prevent condensation.

The loading should be carefully watched and when the top silicone fluid reaches a temperature of 60°C, the load should be reduced to obtain an approximately constant top silicone fluid temperature based on the following table:

Short Circuit Amperes in Percent of Load	Maximum Temperature of the Top Silicone Fluid
50%	85°C
75%	80°C
85%	75°C

While the windings of the transformer heat up, do not permit the temperature of the top silicone fluid to exceed the value specified for a given percentage of load. This precaution is necessary because the windings will heat up more quickly and operate at a higher temperature than the silicone fluid. If the windings are allowed to reach too high a temperature, the insulation will be damaged. The drying of a transformer should be continued until the dielectric strength of samples of silicone fluid taken from the transformer test at 30 KV or higher.

The cover should be kept tightly sealed during the temperature run, and until the transformer has cooled down to room temperature to prevent condensation. This also prevents the release of hot silicone fluid vapors which are quite objectionable, particularly, if the ventilation is poor.

CAUTION: It is not safe to attempt the drying out of transformers unless constant attention is given to the job. Overheat will damage the insulation, leaks will let moisture enter the unit or improper handling will release silicone vapors.

ACCESSORIES AND FITTINGS

Bushings, fittings, and accessories when boxed and shipped separately should be mounted as shown on the outline drawing. Proper installation instructions when necessary are included in the instruction leaflets for component parts. Care must be exercised when these components are fitted to eliminate the accidental introduction of moisture in any form inside the transformer. When blind flanges are removed before fittings are mounted, the level of the silicone fluid must be lowered below the openings that will be made.

FINISH

Any portion of the paint film damaged during shipment or installation must be repaired as quickly as possible.

To do this, clean the damaged portion by means of a scraper or sandpaper, wipe thoroughly with a solvent dampened cloth, apply Westinghouse primer paint and allow it to dry for at least 24 hours, then apply a coat of Westinghouse finish paint.

FILLING

When putting new apparatus into service, see that the apparatus tank is free from moisture and foreign material.

IMPORTANT: Extreme precautions must be taken to insure the absolute dryness and cleanliness of the apparatus before filling it with silicone fluid, and to prevent the entrance of water and dirt during the transfer of the silicone fluid to the apparatus. Failure to do so may result in lowering of the dielectric properties.

The preparation and filling of outdoor apparatus should preferably be done on a clear, dry day; if this is not possible, protection against moisture must be provided.

All vessels used for transferring the silicone fluid should be carefully inspected to see that they are absolutely dry and free from contamination. There are some pump designs and materials which will wear very rapidly when used to pump silicone fluids. The technical departments of pump manufacturers should be consulted before using any pump for transferring silicone fluids. All joints should be tight; where practical, fill through the drain valve to keep aeration to a minimum and vent the top of the tank to allow the air to escape. Be sure that valves and pipe connections between the main tank and any silicone fluid filled compartments are open for free circulation of gas and liquid. Otherwise, trapped air or gas may cause the silicone fluid level in some parts of the transformer to be below the safe operating level.

If it is necessary to fill a transformer out-of-doors, particularly on a damp day, care should be taken to prevent the entrance of moisture. In order to avoid condensation the temperature inside the unit should be kept several degrees above the outside air temperature.

The tank and compartments, if any, should be filled at ambient temperature to the point on the gauges marked "25° – Liquid Level." If the ambient varies greatly from 25°C (77°F) when filled, the silicone fluid level should be checked when the average fluid temperature is 25°C; sufficient silicone fluid should be added to or drained from the tank to bring the level to the proper height. The transformer should never be operated or left standing, even out of service without the silicone fluid level being indicated on the gauge.

Filling Under Vacuum. Entrapped air is a potential source of trouble in all liquid filled transformers. Therefore, it is desirable to fill all silicone fluid transformers under a full vacuum. This is done for the transformers shipped from the factory and should be done where practicable when transformers are filled in the field, providing the transformer cases have been so designed. If the cases have not been designed for full vacuum and it is imperative to get the maximum winding impulse strength immediately, the transformers should be filled with silicone fluid under full vacuum by placing them in an auxiliary vacuum tank.

Where purchaser does not have an established technique for vacuum filling, the following procedures may be used whether vacuum is applied directly to the transformer or the complete transformer is placed in an auxiliary vacuum tank.

1. Apply and maintain continuously a vacuum of at least 28 inches of mercury for at least one-half hour to units rated 25 KV and below, or for four hours to units above 25 KV.
2. While retaining the vacuum, slowly fill with silicone fluid to the normal 25°C level or with approximately 90% of the required amount where it is impossible to gauge properly.
3. Maintain the specified vacuum for at least one-half hour after filling.
4. Adjust silicone fluid to normal level and seal the transformer tank. Do not reopen until the temperature at the top of the fluid is equal to or higher than the ambient temperature in order to avoid condensation on the surface of the silicone fluid.

In those cases where the transformers are not filled under vacuum, full voltage should not be applied to the windings for at least 24 hours after the silicone fluid has been put into the case. This time is necessary to allow the air bubbles to escape.

PLACING IN SERVICE

Pressure Testing. All silicone fluid transformers are pressure tested at the factory and shipped free of leaks. After installations and before voltage is applied, it is desirable to pressure-test each transformer, especially if any fittings or covers have been removed and replaced during installation. Compressed dry nitrogen or dry air may be used for this purpose. It is recommended that the space above the silicone fluid be blown out with dry nitrogen, then close all vents and apply a pressure test of five pounds per square inch for a period of six to eight hours. The test pressure can best be limited by the use of a pressure regulator attached to the nitrogen cylinder. A check for leaks of joints above the silicone fluid level may be made by painting them with a solution of soap and glycerin and watching for gas bubbles. At the conclusion of the test the internal pressure should be returned to normal by momentarily venting the gas space.

High Altitude. Where transformers are to be used at a high altitude (more than 3000 feet above sea level) a fitting above the liquid level should be opened to equalize the internal and external pressures at a temperature of approximately 25°C before placing the transformer in service.

Grounding Transformer Tank. Regardless of the type of foundation or floor on which a transformer is to rest, the tank should be definitely and permanently grounded to eliminate the possibility of obtaining static shocks or being injured by accidental grounding of a winding to the case. A ground pad or lug is always provided near the bottom of the tank for the purpose of connecting the grounded lead.

CAUTION: A good low-resistance ground is required for all transformers for adequate protection. Failure to ground the tank could cause danger to life and damage to property.

Grounding Low Voltage Winding. Every effort is made in insulating transformers to guard against

any change of breakdown between high voltage and low voltage windings, however, in order to be absolutely safe, it is advisable that low voltage circuits with which persons may come in contact be grounded. The maximum voltage that can be obtained is then limited to the normal voltage that exists between the grounded point and the line; this is true even though the high voltage and low voltage windings become connected electrically.

In grounding the winding, the neutral point should be used if it is available. When transformers operate on single phase circuits with the middle point of the low voltage, the maximum voltage that can exist between any part of the low voltage circuit and ground is one-half of the low voltages.

MAKING CONNECTIONS

A diagram, usually on the metal instruction plate attached to the side of the case, shows the proper power terminal connections to be made for various voltages. Care should be taken to see that all connections and only those shown are properly made, for a wrong connection may cause severe damage.

Some installations require an auxiliary source of power or control leads to be wired to terminals at the transformer; a wiring diagram, either a separate drawing or included as part of the outline drawing, shows the connections to be made.

Voltage Application. When voltage is first applied to the transformer, it should, if possible, be brought up slowly to its full value so that any wrong connection or other trouble may be disclosed before damage can result. After full voltage has been applied successfully, the transformer should be operated without load for a few hours. It should be kept under close observation during this time and also during the first few hours while loaded.

INSPECTION

It is desirable that periodic inspections of silicone fluid apparatus be made and that samples of silicone fluid be taken from each and from all compartments of any apparatus and tested after a short period of service. See section on Sampling and Inspection.

Any increase in operating temperature at normal load should be investigated and if the cause cannot be determined, the transformer be taken out of service and given a thorough inspection.

Any symptoms, such as unusual noises, high or low silicone fluid levels, operation of relief device, etc., should be investigated at once.

Transformers which have been subjected to unusually severe operating conditions, such as overload, frequent short circuits, or special units should be inspected at least once a year. This can usually be done adequately by lowering the

silicone fluid level and inspecting with a light through the manhole.

During periodic inspection, all accessories should be inspected to see if they are operating properly.

CAUTION: Never enter a vault or any other confined area in which a transformer relief device has been known to operate or in which a transformer has failed, until the area has been thoroughly ventilated. Gases released may be toxic and could cause danger to life. Then enter cautiously, with another person in attendance.



Westinghouse

THE LEADER OF THE TRANSFORMER INDUSTRY

www.ElectricalPartManuals.com