

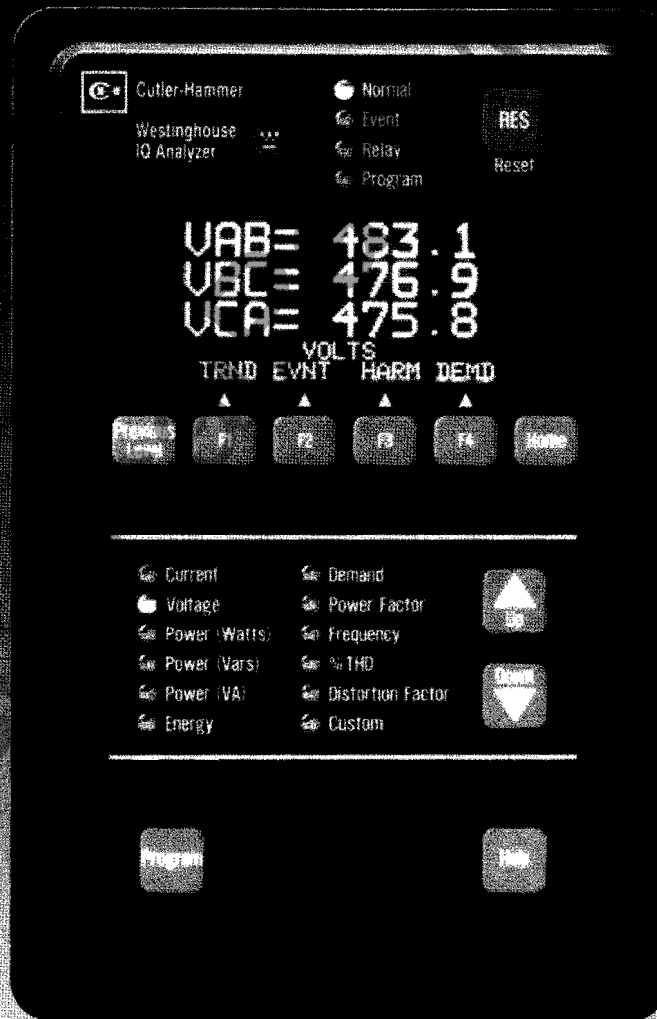

Westinghouse IQ Analyzer

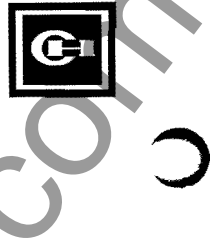

WWW.Eaton.com



IQ Analyzer-Comprehensive Electrical Distribution Monitoring

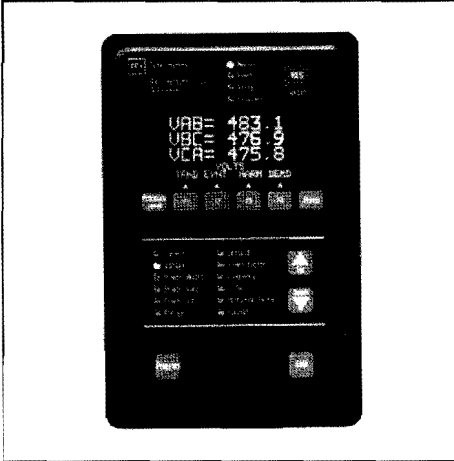

The IQ Analyzer is a complete solution for users who want to monitor all aspects of their electrical distribution system. Based on input from customers and consultants, it provides extensive metering, power quality analysis, remote input monitoring, control relaying, analog input/outputs and communications capability.

Its high performance metering complies with the rigid ANSI C12.16 Class 20 accuracy specification for revenue meters, provides quality true rms readings through the 50th harmonic, accurately measures nonsinusoidal wave forms up to a 3.0 crest factor, and displays even and odd multiples of the fundamental current and voltage through the 50th harmonic. Both magnitude and phase angle of the harmonics are displayed^①.

The unique operator interface, which includes a gas plasma display, easy to use *Meter Menu* screens and detailed *Analysis* screens, is designed to allow a wealth of real time and recorded information to be accessed easily by an operator. *All* programming can be accomplished through the faceplate or the communications port. The on-line Help feature provides useful information on device operation, programming and troubleshooting.

Accuracy

Currents and Voltages	± 0.20%
Power, Energy, and Demand	± 0.40%
Frequency	± 0.40%
Power Factor	± 0.80%
Accuracy maintained from 3-300% of full scale and from -0.50 to 1.00 to 0.50 power factor.	

IQ Analyzer Highlights

A Wealth of Information

The IQ Analyzer displays the most comprehensive list of metered parameters in its class. The dot matrix, gas plasma display provides the flexibility of exhibiting large characters with high visibility and small characters for detailed descriptions.

Multiple parameters (e.g., currents of phases A, B and C) are displayed simultaneously for more thorough real-time monitoring. *Custom* screens can even be configured to view a grouping of parameters (e.g., volts, Amps and power factor) for convenience or to concurrently observe their relationships as conditions change.

Easy to Use

The IQ Analyzer's *Meter Menu* makes commonly viewed parameters easy to access and understand. For additional information, the *Analysis* screens provide comprehensive data on harmonic distortion, current and power demands, trending and events/alarms. The IQ Analyzer even has a *HELP* button to assist in programming, troubleshooting and operating the device.

Extensive Harmonic Distortion Analysis

Current and voltage distortion data are displayed at the device and accessible through the communications port. This includes %THD, K-Factor, Crest Factor, CBEMA factor, and both magnitudes and phase angles of all harmonics through the 50th. A snapshot sample of this information may be activated by user commands, discrete inputs or programmable thresholds to capture distortion data during conditions of real interest. To help eliminate nuisance alarms, harmonic distortion information can be captured and relay outputs activated when THD exceeds a programmable percentage of fundamental or a programmable magnitude (e.g., amperes) threshold.

Disturbance Information

With the communications option and our IMPACC Series III and Wave Form Display software, a *Wave Form Analysis* will construct wave forms of up to 56 cycles of all currents and voltages (including neutral and ground) to help troubleshoot undervoltage/sag and overvoltage/swell conditions. By programming a reset threshold, the duration of the voltage disturbance can also be indicated.

High Accuracy

Advanced electronic circuitry enables the IQ Analyzer to comply with the rigid ANSI C12.16 Class 20 accuracy standard for revenue meters. In addition, accuracy is maintained in applications with high distortion levels, including systems exhibiting a 3.0 Crest Factor and harmonics up to the 50th multiple of the fundamental.

Extensive I/O and Communications Capability

One analog and three digital inputs are provided to interface with sensors and transducers. Three analog output and four relay contacts are furnished to share data with PLCs and control systems and to actuate alarms and control relays. Terminals are captive clamp type and finger safe. With the communications option, the device can be remotely monitored, controlled and programmed.

Minimal Installed Cost and Space

The functionality of dozens of meters, relays and recorders is provided in less than 7 in. by 11 in. of panel space (the same cutout as other IQ products). The *Flange* option also enables mounting on assembly doors which do not allow enough clearance for most other meters. External pts are required only above 600 Vac. The device is fully programmable from the faceplate; a PC/PLC investment is *not* required to program the device.

Flexible Power Supply Options

Two different styles of the Analyzer are available. The first is catalog number IQA (Style #2D82302G01), which is powered from the three-phase line it monitors. The second catalog number IQAS (Style #2D82302G02), will accept separate source, single-phase 120/240 Vac control power.

Displayed Information

The IQ Analyzer is designed to provide a comprehensive array of metered parameters, while at the same time making this information easy to use by any operator.

The IQ Analyzer provides easy access to the most commonly viewed parameters through its LED indicator *Meter Menu*. More detailed information on alarm data, historical values, harmonic profiles and peak demands is accessible through its function key driven *Analysis* screens.

Displayed Information Features

- All information accessible through communications port via IMPACC
- Quality true rms readings through 50th harmonic
- Complies with ANSI C12.16 Class 20 revenue metering specification for accuracy
- Accurate readings for nonsinusoidal wave forms with up to 3.0 crest factor
- Screens display auto ranging units, kilo units, mega units as needed
- 10-Digit energy readings
- Displays multiple parameters at the same time
- Programmable Custom Screens

^① For definition of power quality terms, see page 3.



Meter Menu Screens

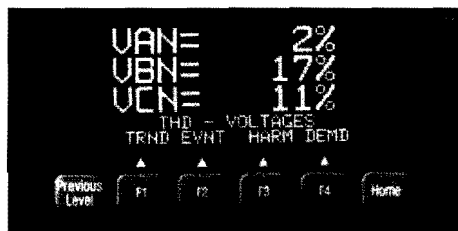
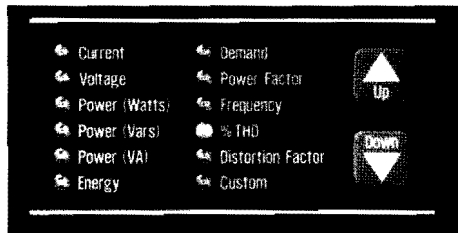

Meter Menu and Examples of Meter Menu

The IQ Analyzer allows a user to view commonly used parameters by scrolling through its LED indicator Meter Menu.

Meter Menu Displayed Information

- Current - Phases A, B, C, Average
 - Neutral
 - Ground (Separate ct)
- Voltage - Phases A-B, B-C, C-A, Average
 - Phases A-N, B-N, C-N, Average
 - Neutral-Ground
- Power - Real (watts)
 - Reactive (vars)
 - Apparent (VA)
 - Phases A, B, C, and system
- Energy (Forward, Reverse and Net)
 - Real (kWh)
 - Reactive (kvarh)
 - Apparent (kVAh)—no reverse or net
- Frequency, time and date
- Demand - System current (Amps)
 - Systems real power (kW)
 - System reactive power (kvar)
 - System apparent power (kVA)
- Power Factor (Phases A, B, C, System)
 - Displacement
 - Apparent
- %THD Current - Phases A, B, C, N
- %THD Voltage - Phases A-B, B-C, C-A
 - Phases A-N, B-N, C-N
- K-Factor
- CBEMA Derating Factor (Displayed as "Z")
- Crest Factor
- Discrete Input and Output Status
- Analog Input Reading
- Custom - User may program two screens to show any combination of seven Meter Menu parameters per screen.

① One second resolution at the device; 10 msec resolution through software.

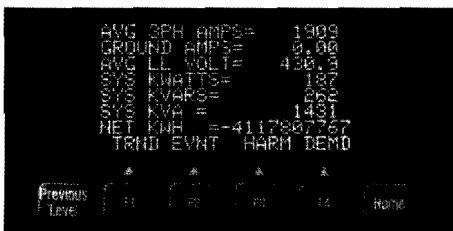

Examples of Custom Screens

Analysis Screens



Operator About to Access the Trend Analysis Screens

The Analysis screens provide detailed information on trends, recorded events/alarms, harmonic distortion and peak demands of current and power. Pressing the appropriate function key accesses the Trend Analysis, Event Analysis, Harmonic Analysis and Demand Analysis screens.

Trend Analysis Screens

The F1 function key accesses the Trend Analysis Screens. These consist of time and date stamped minimum and maximum values for the following parameters:

Minimum and Maximum Values:

- Current - Phases A, B, C, N, G
- Voltage - Phases A-B, B-C, C-A
 - Phases A-N, B-N, C-N, N-G
- Power - Real (watts)
 - Reactive (vars)
 - Apparent (VA)
 - Phases A, B, C and System
- Power Factor - Apparent (3-Phase and System)
 - Displacement (3-Phase and System)

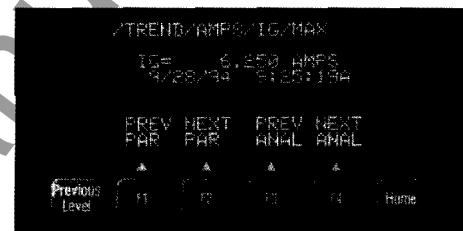
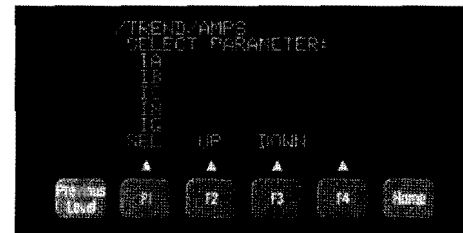

Example of Trend Analysis Screens

- Frequency
- THD - Current (Phases A, B, C, N)
 - Voltage (Phases A-B, B-C, C-A, A-N, B-N, C-N)

All minimum/maximum values may be reset via reset pushbutton on faceplate, discrete input or communications command. Values are updated at least once every 16 line cycles.

Definition of Power Quality Terms

Displacement Power Factor

- A ratio of fundamental (60 Hz) real power to apparent power.
- = Fundamental (60 Hz) watts to VA.

Apparent Power Factor

- A ratio of total real power (including harmonic component) to reactive power.
- = Total rms watts to VA.

K-Factor

- A derating factor which is related to the sum of the squares of harmonic currents times the squares of their harmonic numbers (multiples of the fundamental).

CBEMA Factor

- A transformer harmonic derating factor (THDF) defined as a pure sine wave's crest factor (1.414) divided by the measured crest factor.

Crest Factor

- Ratio of peak current to rms current.



Harmonic Analysis Screens

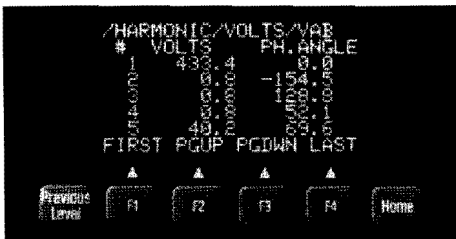
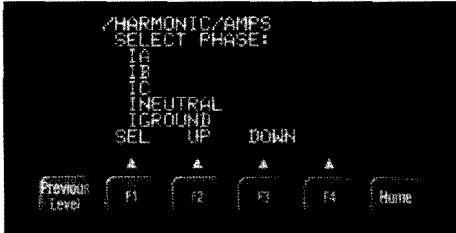

Examples of Harmonic Analysis Screens

The F3 function key accesses the Harmonic Analysis screens. Two cycles of data sampled at **128 samples/cycle** are **simultaneously** recorded for:

- Current - Phases A, B, C, N, G
- Voltage - Phases A-B, B-C, C-A
- Phases A-N, B-N, C-N

Magnitudes (or % of fundamental) of odd **and even** multiples of the fundamental from 2nd - 50th are displayed. The phase angle associated with each multiple of the fundamental is also displayed.

Event/Alarm Analysis Screens



Examples of Event Analysis Screens

Pressing the F2 function key accesses the Event Analysis screens. These display the following data for up to ten event/alarm conditions:

- Description, date, and time of event/alarm^①
- Current, voltages, power readings, demand readings, frequency and %THD at time of event/alarm
- Current and voltage distortion information available on Harmonic Analysis screens.

Event data is stored in non-volatile memory. If a reset threshold is programmed, the *duration* of the event (e.g., undervoltage) is also displayed. With the IMPACC communications option and Series III software, wave forms and harmonic profiles may be displayed on a PC.

Event/Alarm Conditions

Events/alarms may be triggered by up to seven of the following 39 conditions:

Voltage Disturbances

- 1-2: Undervoltage/sag—any V_{LL}, V_{LN} (50-100%)^②
- 3-4: Overvoltage/swell—any V_{LL}, V_{LN} (100-150%)

If no time delay is programmed, any disturbance lasting 2 cycles (less if magnitude is sufficient to effect RMS readings) will trigger a voltage disturbance event/ alarm.

Maximum Threshold Exceeded

- 5-13: %THD (2-1000) **or** Magnitude of THD;
 - Current - Phases A, B, C
 - Voltage - Phases A-B, B-C, C-A, A-N, B-N, C-N

- 14-20: Demand
 - Current—Phases A, B, C, N
 - System Power—watts, vars, VA

- 21: Voltage - Neutral to Ground

- 22-23: Current - Neutral or Ground

Minimum or Maximum Threshold Exceeded

- 24-26: Current - Phases A, B, C
- 27-29: System Power - watts, vars, VA

- 30: Frequency

- 31-32: System Power Factor (minimum – displacement or apparent)

Voltage Phase Unbalance

- 33-34: Voltage L-L, L-N

Current Phase Unbalance

- 35: Current—Phases A, B, C

Discrete Input Energized

- 36-38: Input 1, 2, 3

IMPACC Communication

- 39: Remote command through communications port

All trigger conditions have programmable time delays from 0.1 to 60 seconds in 0.1 second increments (except Voltage Disturbances—programmable from 2 - 3600 cycles in 2-cycle increments, and IMPACC command—no programmable delay).

Demand Analysis Screens

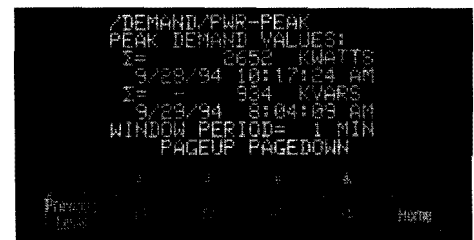
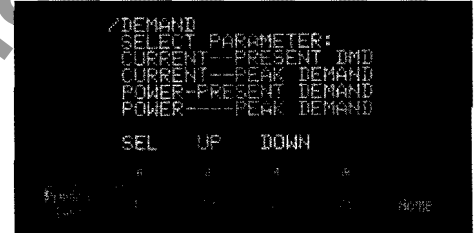

Examples of Demand Analysis Screens

The F4 function key accesses the Demand Analysis screens. Demand window are programmable from 5 to 60 minutes; power demands may be updated at 1 - 60 minute subintervals (sliding windows).

Peak Demands are date and time stamped^① for:

- Current Phases A, B, C, average
- System Power - Real (watts)
- Reactive (vars)
- Apparent (VA)

① One second resolution at the device; 10 msec resolution through software.
② 60% minimum for self-powered unit.

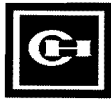

Input/Output Capabilities

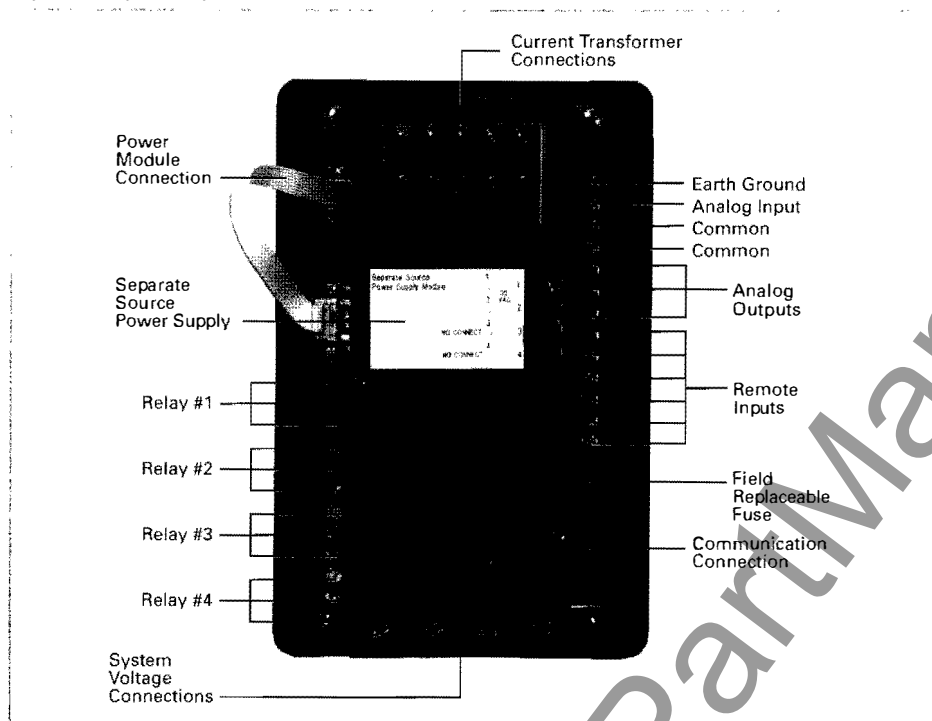

IQ Analyzer Rear View (Separate Source Power Supply Shown)

Extensive input/output capability is standard on the IQ Analyzer. In addition to monitoring three-phase currents and voltages, separate inputs are provided for both ground and neutral currents. Voltage of neutral-to-ground is also monitored to indicate the presence of harmonics and potential downstream grounding problems. Analog and digital I/O provide interfaces for transducers, relays, PLCs and control systems.

Current Inputs

Five ampere secondary ct connections for:

- Phases A, B, C
- Ground
- Neutral
- Separate ground and neutral ct inputs.
- Ct range 5:5 to 10,000:5 (any integer)

Voltage Inputs

- Phases A, B, C (from 120 Vac - 500 kVac)
- 120/240 Vac control power input standard—not required with optional line power module
- Separate ground-to-neutral voltage reference.
- Pt range 120:120 to 500,000:120 (any integer)

External 120-Volt secondary Pts are required above 600 Vac, optional from 120-600 Vac.

Discrete Contact Inputs

Three dry contact discrete inputs may be programmed by the user to:

- Trigger Event/Alarm Analysis—the information described in “Event Analysis Screens,” including Harmonic Analysis information, can be recorded when external devices trip or change state by wiring their auxiliary contacts into these inputs.
- Act as a synch.-pulse input to synchronize power demand windows with utility provided synch. pulse.
- Actuate a relay output
- Reset relay output, peak demands, Trend Analysis records and Event Analysis records.
- With communications option, provide remote status indication on IMPACC network.

Status of input contacts is displayed in the Meter Menu Custom screen.

Relay Output Contacts

Four Form-C (NO/NC) relay contacts may be independently programmed to:

- Act as a kWh, kVarh or kVAh pulse initiator output.
- Actuate on one or more event/alarm conditions—including discrete input and IMPACC command (through communications port).

Each Relay may be set for Auto or Manual Reset with 0-30 minute release delay (one second increments). Relays are Form-C NO/NC. Relay(s) programmed to actuate on undervoltage also have a programmable 0-30 minute delay on power-up for transfer applications.

Analog Input and Outputs

One analog input and three analog outputs may be configured as 0-20 or 4-20 mA. The analog input is displayed at the device as a percentage and is accessible through the communications port. The analog input provides an interface with gas flow meters, temperature transducers or other analog devices.

The analog outputs may be programmed to reflect any of the following:

- Current - Phases A, B, C, Average, N, G
- Voltage - L-L, L-N, N-G
- Power - Real (watts)
 - Reactive (vars)
 - Apparent (VA)
 - Phases A, B, C and system
- Demand - Current (Phases A, B, C, Average, N, G)
 - Power (watts, vars, VA) of system
- %THD - Current (Phases A, B, C, Average, N, G)
 - Voltage (L-L, L-N, N-G)
- Frequency - System

Other Faceplate Features

Status LEDs



Four LEDs at the top of the faceplate provide a quick snapshot of the IQ Analyzer's status:

- **Normal** - Pulsing green LED indicating power to the unit and that the device is operating properly.
- **Event** - Red LED indicating an Event has occurred and data is available in the Event Analysis screens for review.



- **Relay** - Red LED indicating one or more of the four Form-C relays has changed from its normal operating state.
- **Program** - Red LED indicating program mode has been selected and program screens are on the display. This LED also lights up if program settings are downloading through the communications port.

Resetting the IQ Analyzer-Reset Pushbutton

Pressing the Reset Pushbutton prompts the password protected Reset Display Screen, allowing an operator to:

- Reset Relay Outputs
- Reset Peak Demands
- Reset Minimum/Maximum Values
- Reset Event Analysis Records

Resets may also be programmed to operate through a discrete input contact(s) and the communications port.

Program Pushbutton

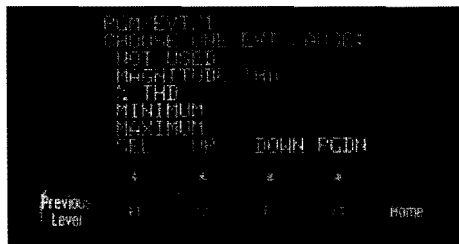
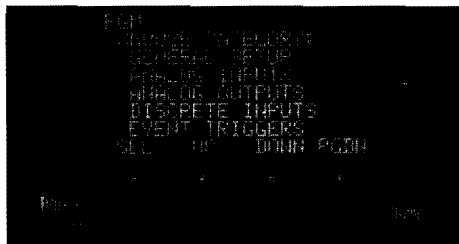

The IQ Analyzer may be completely programmed via the Program pushbutton on the faceplate. To facilitate programming, settings are organized by category and selected by the F1 - F4 function keys. Programming is password protected and may also be accomplished through the communications port.

On-Line Help Feature

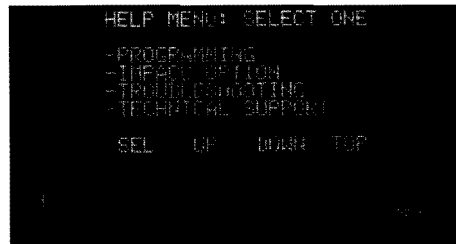
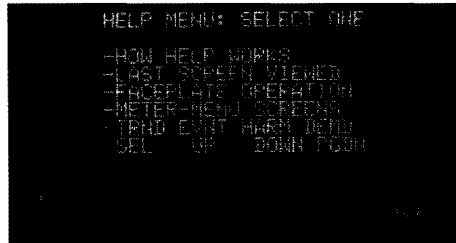

Examples of Help Screens

Pressing the IQ Analyzer's Help pushbutton allows a user to view Help screens on:

- Faceplate Operation
- Programming
- Meter Menu Screens
- Technical Support
- Trend, Harmonic, Event and Demand Analysis Screens
- Resetting

IMPACC Communications Option

IMPACC-Integrated Monitoring Protection and Control Communications-is a noise immune communications system that cost effectively and easily gathers information from metering, protection and control devices. IMPACC provides the capability to control devices and read, log and trend information over a single twisted pair of wire. IMPACC may be installed in new gear or retrofitted into existing equipment.

A variety of IMPACC compatible products can be added to all levels of a commercial or industrial electrical distribution system-from high-voltage substations down to switchboards, panelboards and even individual breakers and motor starters. The back page lists the IMPACC compatible devices presently available.

Adding the communications option to the IQ Analyzer allows it to be remotely monitored, controlled and programmed. Communications is achieved by mounting a small, addressable communications module-the "PONI" card-to the back of the unit.

Functions Available Through Communications:

- Monitoring and trending of displayed values and device status
- Initiating a harmonic analysis and retrieving wave form display information
- Retrieving event/alarm information, including wave form display information at time of event/alarm
- Programming the device

Series III and Enhanced Graphics

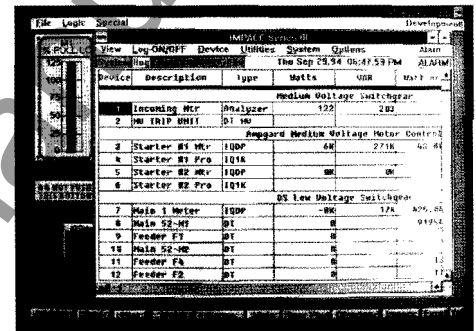

Examples of Series III and Enhanced Graphics Screens on PC

Series III

Series III software provides monitoring and recording of power distribution system data as it is occurring. Series III is a Microsoft Windows-compatible application that features user-friendly, menu-driven screens with easy set-up and operation. Other features include:

- System/device alarm logging and reporting
- Time/event historical data logging
- Data trending
- Information storage and retrieval by device event
- Hardware diagnostics
- Dedicated computer not required
- Security/password protection

Series III version 6.40 and higher support the IQ Analyzer.



Series III Wave Form Display Software and Harmonic Profile Screens

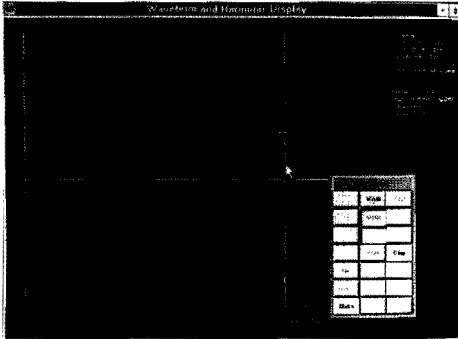

Example of Wave Form Display Screen

When an Event/Alarm occurs (see "Event Analysis" description) or when given an IMPACC command, the IQ Analyzer **simultaneously** records **eight** cycles of all currents and voltages:

- Current - Phases A, B, C, N, G
- Voltage - Phases L-L
 - Phases L-N
 - Neutral-to-Ground

These eight cycle wave forms may be viewed on Series III Wave Form Display software. Six cycles are sampled at 32 samples/cycle; two of them undergo high-speed sampling (128 samples/cycle) for THD, K Factor, CBEMA derating and Crest Factor readings. This high-speed sampling is also used to construct the Harmonic Profile screens to graphically display the relative magnitudes of the multiples of the fundamental frequency (for both current and voltage) as shown below.

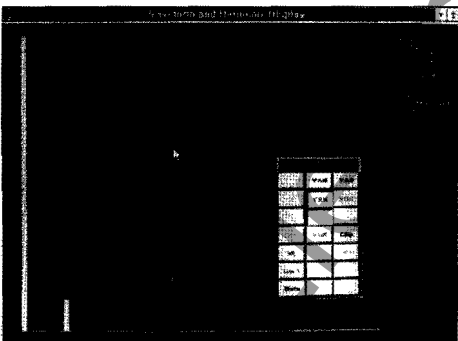

Example of Harmonic Profile

Analyzing Voltage Disturbances With Series III

The Wave Form Display screens display 8 line cycles of voltage and current information. Since the Analyzer is continually monitoring and storing this data, the wave form display can show information up to six cycles prior to sensing a disturbance. If programmed to do so, a disturbance of up to 56 line cycles may be chained together on the Wave Form Display screens. The duration of the disturbance is also indicated.

Since current and voltage sampling is done at the same time, the current and voltage wave forms for a given phase may be simultaneously displayed. Doing so can indicate the direction of the voltage disturbance.

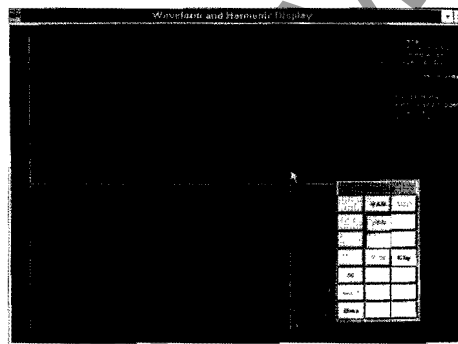

Example of Simultaneous Current and Voltage Displayed on Wave Form Analysis Screen

Enhanced Graphics

Enhanced Graphics software provides the capability to generate custom animated color graphics. For example, animated one line drawings of electrical power distribution systems, flow diagrams of processes, equipment elevation views, and other graphical representations may be developed.

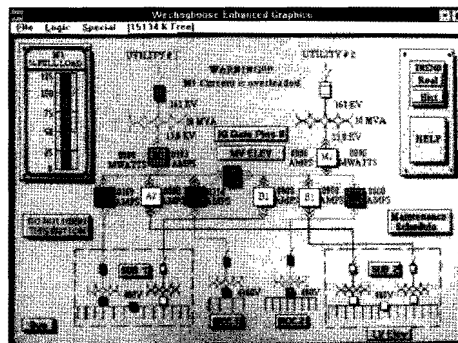

Example of Enhanced Graphics Screen

IMPACC Connectivity

IMPACC makes communications easier by providing a wide range of interfaces to other vendors that make the centralization of power distribution information possible. An IMPACC System can easily be linked to building management systems, programmable logic controllers, and distributed control systems. This provides the capability to move data between and across different levels within an installation.

Interfaces have been developed with several vendors including Wonderware, Johnson Controls, Honeywell, Allen-Bradley, Bailey, Expert Edge, Fisher-Provox, Siemens, Foxboro, Iconics, Intellution, and Modicon.

IMPACC connectivity provides for maximum flexibility, meaning computers and PLCs can communicate with each other; or multiple computers in various locations communicating with each other.

Information from Series III can be exchanged via DDE with other Windows™ based programs such as Excel, Word, or any other DDE-compatible program. For higher performance, information can be shared via NET BIOS which connects Series III to Ethernet, Arcnet, or any other compatible network.

WWW
January 1995



Retrofit Applications and Accessories

IQ Analyzer Flange Option

For applications where extra door mounting space is required, a flange-mounting unit is available. The IQ Flange provides an extra 2.5 inches of clearance for the device.

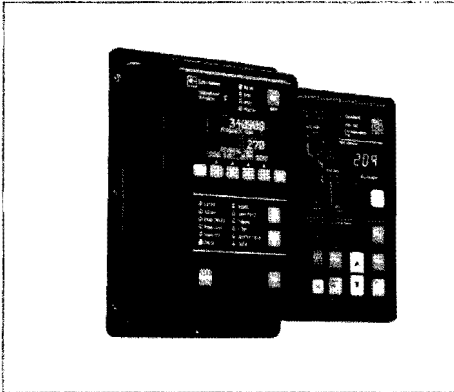

Field Wiring Connections – Separate Source Power Supply Shown Here (For Three-Phase Power Supply, No Separate Control Power is Required)

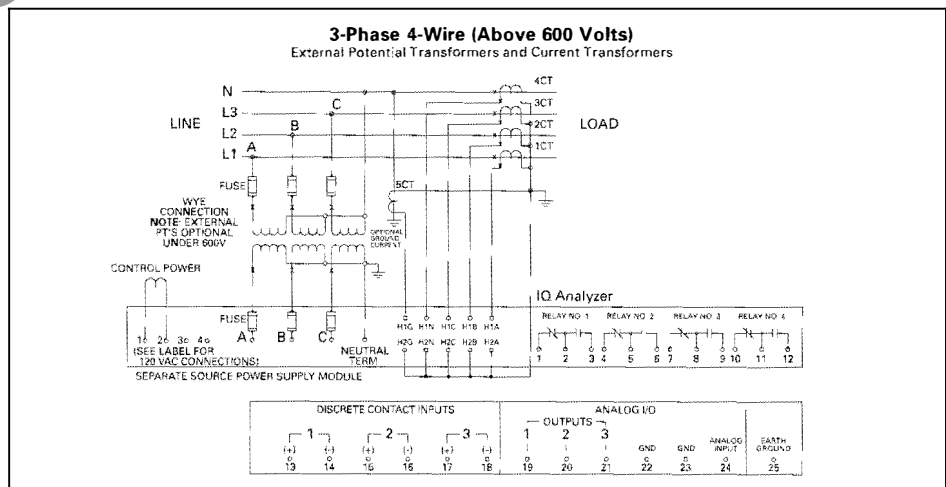
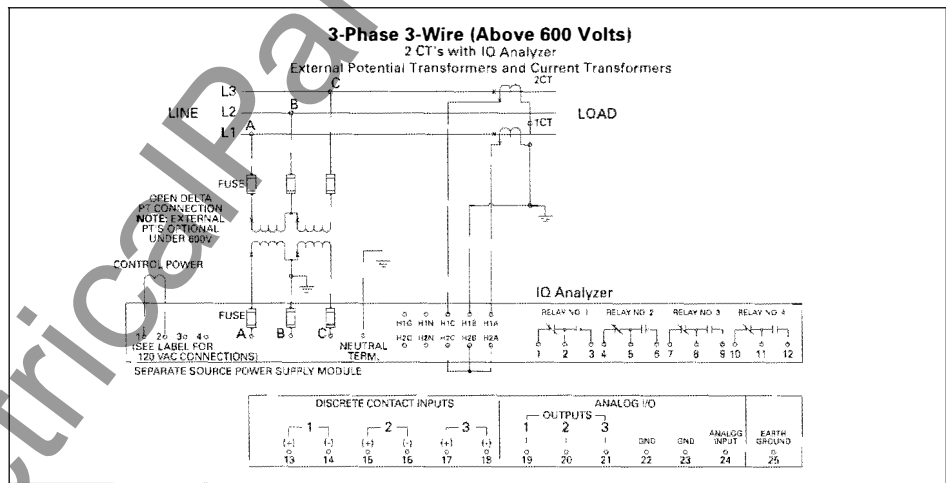
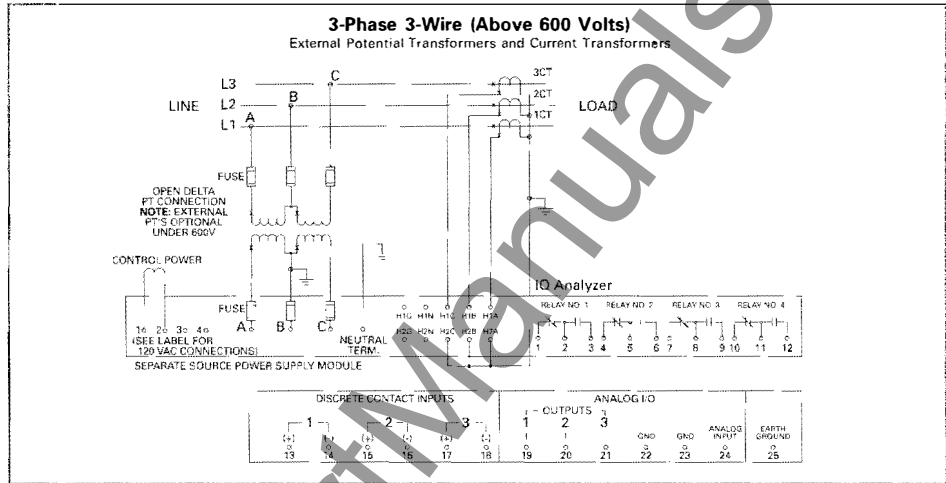



Dimensions and Cutout

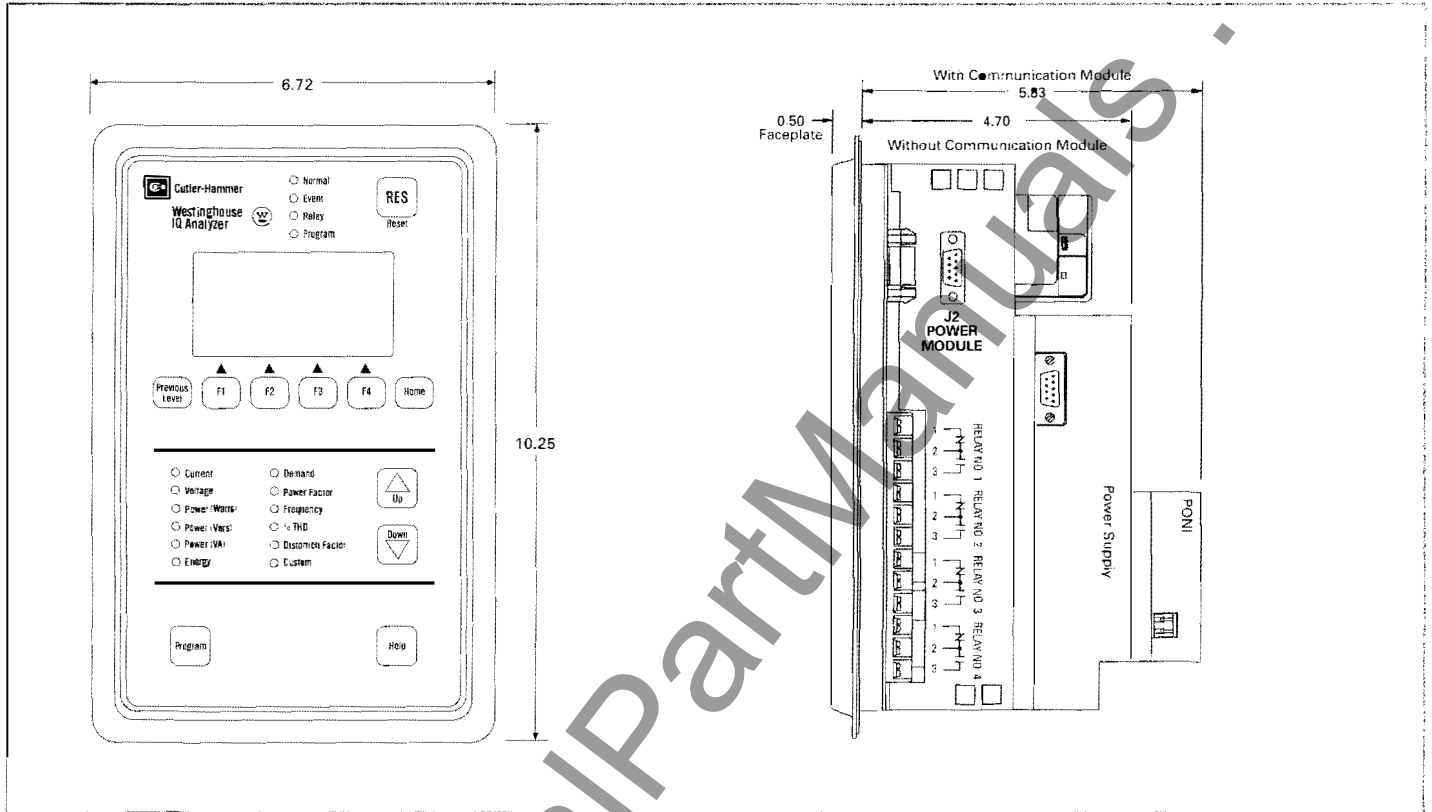

Drilling Pattern

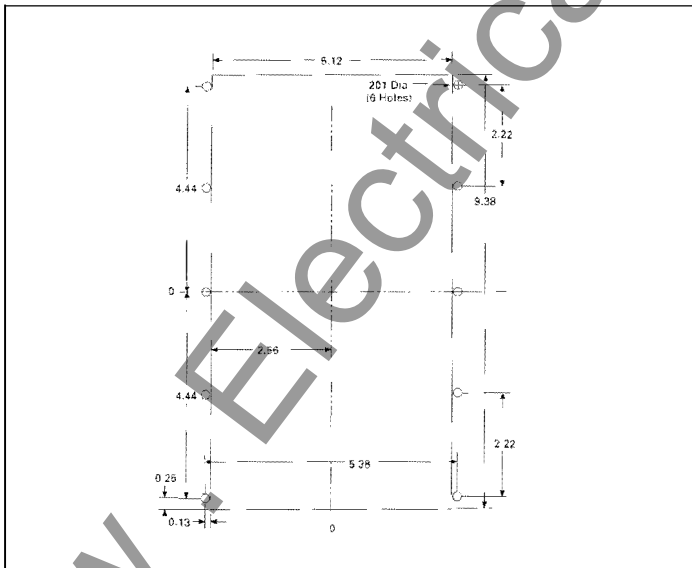

Drilling Pattern for Flange Mounting

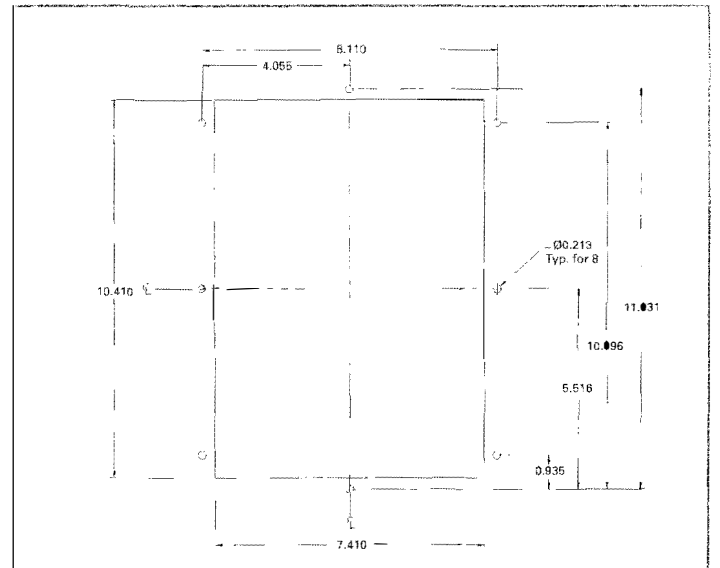



Typical Specifications

IQ Analyzer

1. Where indicated on the drawings provide a digital line Meter Analyzer and Protection (MA&P) device equal to Cutler-Hammer type Westinghouse IQ Analyzer having the features and functions specified below.
2. The MA&P shall provide direct reading metered or calculated values of the items listed below and shall auto range between Units, Kilo-units, and Mega-units for all metered values. The device shall be capable of displaying multiple parameters at once, including two user configurable custom screens displaying any seven of the parameters listed. Indicator LED shall always remain active to display device status for safety and troubleshooting purposes. Time, date, software version and network address shall also be displayed. Accuracy indicated below to be of read or calculated values.
 - a. AC Current (amperes) in A, B, and C phases, 3-Phase Average, Neutral (N) and Ground (G). Accuracy $\pm 0.2\%$ (provide neutral and ground current transformer).
 - b. AC Voltage (volts) for A-B, B-C and C-A, Phase Average, A-N, B-N and C-N, Average Phase to N, and N to G. Accuracy $\pm 0.2\%$.
 - c. Real Power (watts), Reactive Power (vars), Apparent Power (VA) for each phase and system. Accuracy $\pm 0.4\%$.
 - d. Real Energy (Whr), Reactive Energy (varhr), Apparent Energy (VAhr) for each phase and system (system shall apply only for 3-wire applications). Accuracy $\pm 0.4\%$. Forward/Reverse indication shall be provided.
 - e. Frequency (Hz). Accuracy $\pm 0.4\%$.
 - f. Demand values for System Current (amperes), System Real Power (watts), System Reactive Power (vars) and System Apparent Power (VA).
 - g. Power Factor both Displacement (60-cycle fundamental watts to VA) and Apparent (total watts to total vars including harmonics for A, B and C phases and system). Accuracy $\pm 0.8\%$.
 - h. Current Percent Total Harmonic Distortion (THD) in A, B and C phases, and N.
 - i. Voltage percent THD in A-B, B-C, and C-A phases, and A-N, B-N, C-N.
 - j. K-Factor.
 - k. Transformer Derating Factor (CBEMA Factor).
 - l. Crest Factor.
3. The MA&P shall provide the following advanced analysis features:
 - a. Trend Analysis Screens displaying the minimum and maximum values for each metered value, with all parameters time stamped to 1-second resolution.
 - b. Demand Analysis screens displaying current (phases A, B, C, N, and G) and power (system real, reactive, and apparent, present demand and peak demands). Peak demands shall display time and date stamped to within 1-second resolution. Demand Window Selection for metered demand values shall be selectable either as:
 1. A user selectable fixed window (programmable from 5 to 60 minutes).
 2. Sliding window method with programmable 1- to 60-minute subintervals, for power (kW, kvar, kVA) demand only.
 3. Initiated from a synch pulse for power (kW, kvar, kVA) demand only.
 4. Communication signal initiated from a Cutler-Hammer type Westinghouse IMPACC network master computer.
 - c. Harmonic Analysis Screens shall be capable of being function key triggered to capture a high-speed wave form of two (2) cycles of data sampled at 128 samples per cycle, simultaneously recording current in A, B and C phases, N, and G as well as all voltages A-B, B-C, and C-A phases, A-N, B-N, C-N, and N-G. Data captured shall include the magnitude (% of the fundamental) and the direction of harmonic source (phase angle) for all odd and even multiples of fundamentals from 2nd through the 50th.
 - d. Event Analysis Screens shall display data recorded for up to ten event conditions. The initiation level of the declaration of an event condition shall be field programmable for all measured parameters. For each event a description of the event, date, and time of event (1-second resolution) shall be displayed. In addition, a capture shall be made of all metered values available and current and voltage distortion information harmonic.
 - e. The MA&P shall be capable of transmitting all data at time of the event via communications to a personal computer for creating and displaying wave forms.
- f. Event Condition Levels shall be capable of being triggered when the programmed threshold is exceeded. All triggers shall have programmable time delays from 0.1 to 60 seconds except voltage disturbance which shall be programmable from 2 to 3600 cycles.
4. The MA&P shall be capable of receiving the following inputs:
 - a. Instrument transformers: Input ranges of the MA&P shall accommodate external current transformers with ranges from 10,000/5 through 5/5 amperes. Provide external current transformers for each phase, neutral and ground circuit with rating as indicated on the drawing or sized for incoming service or associated feeder. Potential transformers shall be self-included and fused for up to 600 volts with potential connections suitable for 3-phase 120-volt, 208/220/240-volt, 380/416-volt, 460/575-volt. Above 600 volts, provide fused external potential transformers for up to 500 kV.
 - b. Control Power: The MA&P control power shall be capable of being supplied from the monitored incoming AC line without the need for a separate AC control circuit unless a separate 120- or 240-volt source is indicated on the drawings.
 - c. Dry Contacts: Three (3) dry discrete input contacts shall be furnished which may be programmed by the user to perform any of the following functions. The status of the input contacts shall be locally displayable and accessible through the communications port.
 1. Trigger an Event/Alarm Analysis including Harmonic Analysis information for display on the device and information for Wave Form Analysis and display at a personal computer.
 2. Act as an synchronizing pulse input to synchronize demand windows with a utility provided synchronizing pulse.
 3. Reset a relay output, peak demand, Minimum/Maximum or Event Analysis records.
5. Furnish Relay Output Contacts with four Form-C (NO/NC) relay output contacts which shall be capable of being independently programmed for the following functions:



- a. Act as a kWhr, kVarhr, or kVarhr pulse initiator output.
 - b. Actuate on one or more Event Conditions, including discrete input signal.
6. Furnish one 0 to 20 mA or 4 to 20 mA analog input and three 0-20 mA or 4 to 20 mA outputs. The input values shall be capable of being displayed on the device as a percentage and shall also be accessible throughout the communications port. Each analog output shall be programmable to reflect a phase current, voltage, power, demand, %THD, power factor or system frequency.
7. The device shall be fully programmable from the faceplate, including alarm relay and power quality (e.g., harmonic distortion) settings. Programming shall be password protected.
8. Provide or make provisions for an addressable communication card capable of transmitting all data, remotely controlling and programming the MA&P over a compatible two-wire local area network to a central personal computer for storage, analysis, display and printout. The network shall also be capable of transmitting data in RS232c format via a translator module. The following minimum functions shall be available through communications at the personal computer with appropriate Windows-based software:
- a. Monitoring and trending of all locally displayed values and device status.
 - b. Initiating an Event/Alarm.
 - c. Retrieving Event/Alarm information.
 - d. Retrieving Harmonic Analysis/Wave Form Analysis information including construction of the Harmonic Profile to graphically display simultaneously the relative magnitudes of the multiples of the fundamental frequency for both current and voltage of a given phase.
 - e. Retrieving Harmonic Wave Form Analysis information for display of eight-cycle wave shapes of all simultaneously recorded current (phases A, B, C, N, and G) and voltage L-L and N-G.
 - f. Programming device configuration and setpoints.
 - g. Synchronizing device clocks to within 30 mseconds (for demand windows and time stamping).

Product Specifications

Fuses

(Supplied with the unit) 3/4 ampere, 600 volts Buss Type KTK-R-3/4 (3 required)

Environmental Conditions

Operating Temperature: -20° to 70° C
Storage Temperature: -30° to 85° C
Operating Humidity: 0 to 95%
Relative Humidity
4.7 lbs w/o
Power Module

Device Weight:

Current Input (Each Channel)

Current Range: 0-40 Amps AC
Nominal Full Scale Current: 5 Amps AC
Overload Withstand: 40 Amps AC, Continuous
300 Amps AC, 1 second
Input Impedance: 0.002 ohm
Burden: 0.05 VA

Voltage Inputs (Each Channel)

Voltage Range (Nominal): 0-600 Volts AC
Nominal Full Scale Voltage: 120-600 Vac
Overload Withstand: 635 Vac, Continuous
700 Vac, 1 Second
Input Impedance: 1 Megohm

Frequency Range

45-66 Hertz

Harmonic Response (Voltages, Currents)

50th Harmonic

Accuracy

Accuracy maintained from 3-300% of Full Scale and from -0.5 to 1.00 to 0.5 power factor.

Current and Voltage: ± 0.20%
Power, Energy, and Demand: ± 0.40%
Frequency: ± 0.40%
Power Factor: ± 0.80%

Control Power Input

(Separate Source Power Module Only)
Input Range, AC: 96-264 Vac
Frequency Range: 45-66 Hertz
Input Range, DC: 100-350 Vdc
Burden: 21 VA

Discrete Inputs (Dry Contact)

+30 VDC differential across each discrete input pair of terminals.
Minimum Pulse Width: 1.6 msec
Optically isolated inputs to protect IQ Analyzer circuitry.

Analog Outputs

0 to 20mA / 4 to 20mA into max. 1 kilo-ohm load. Accuracy: 1%.

Analog Input

0 to 20mA / 4 to 20mA into 200 ohm load. Accuracy: 1%.

Relay Output Contacts

Form C Dry Contact: 10 amperes @ 120/240 Vac (Resistive)
10 amperes @ 30 Vdc (Resistive)

Minimum Pulse Width: 4 cycles (68 ms)

Withstand Rating: 1000 Vac, 1 min. across contacts
5000 Vac (contacts to coil, 1 min.)
10,000 Vac (contacts to coil, surge voltage)

Relay Response Time (excluding programmed time delays):

- 2 line cycles for Discrete Input, IMPACC command (communications port)
- 4-5 line cycles for Voltage Disturbance, Voltage Unbalance
- 9-10 line cycles for all others



Product Support

Application Support

Cutler-Hammer sales offices world-wide provide technical assistance in the specification and use of Westinghouse IQ products.

Factory Assistance

Cutler-Hammer provides factory applications and technical assistance to its customers. Available by telephone, Cutler-Hammer personnel quickly respond to customer needs—troubleshooting problems, analyzing system operation, and coordinating component repair or replacement.

Factory assistance may be obtained by calling the Advanced Products Support Center at (800) 542-7883 or (412) 494-3750.

Training

Cutler-Hammer also provides comprehensive training on IMPACC and IMPACC-compatible devices from its Pittsburgh Training Center. The Training Center also offers on-site training for all of its courses. For more information on training, please call (412) 494-3715.

Other IMPACC-Compatible Devices

The unique Westinghouse IMPACC System can monitor and control your entire power distribution system from the utility incoming line through all levels of distribution—down to a 15-ampere circuit breaker or fractional horsepower motor starter. A system can be upgraded as new equipment is added and/or existing equipment is upgraded with Digitrip Trip Units, IQ metering and IQ motor protection devices, Advantge Motor Control and Accutrol 400 and 700 Adjustable Frequency Drives.

IMPACC Compatible Devices

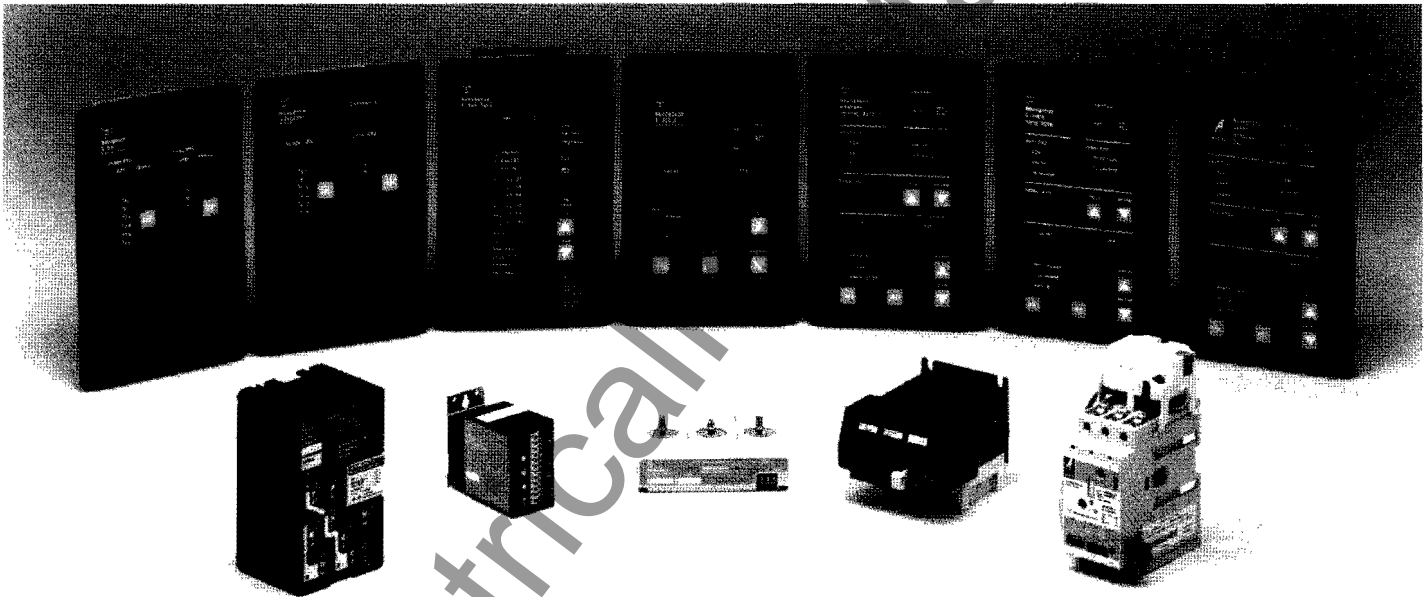

Catalog Number	Style Number	Description
IQA	2D82302G01	IQ Analyzer, power from line
IQAS	2D82302G02	IQ Analyzer, requires separate control power
IQFLANGE	5743B02G01	IQ Flange, to provide extra clearance when mounting
IQACABLE	2701A55G02	36" extension cable for remote mounting IQ Analyzer power supply
S3200	2091A75G11	Series III 6.40, 200 devices
WAVEDISP	8173A41G01	Wave Form Display Software

Cutler-Hammer
Westinghouse &
Cutler-Hammer Products
Five Parkway Center
Pittsburgh, Pennsylvania, U.S.A. 15220

