

Westinghouse



Type CA Single Phase Transformer Differential Relay

Application

Designed for 2-winding transformer protection, the Westinghouse CA transformer differential relay has a constant percentage differential characteristic and inverse timing. It is a single phase unit, and three relays are used for three-phase transformer protection.

The CA relay is equipped with two restraining circuits and one operating circuit in the differential unit. All three circuits produce torque on the induction disc; the restraining circuits producing contact-opening torque, the operating circuit producing contact closing torque.

The amount of operating or contact-closing torque required to trip the relay is a fixed percentage of the restraining torque.

Taps are provided to adjust the relay for mismatch between current transformers.

Operation

Typical external connections for the CA relay are shown in Figure 1.

With the relay connected as shown in Figure 1a, a through fault causes currents to flow through two restraint windings in the same direction. If the current transformers operate properly, these restraining currents are equal, or effectively equal if appropriate autobalance taps are used to compensate for mismatch in current transformer ratios, and no effective current flows in the operating coil winding; thus only contact-opening torque is produced.

If the currents in the two restraining windings are effectively unequal, the effective difference must flow in the operating coil. The operating coil current to overcome the restraining torque and close the relay contacts is a function of the restraining current.

In the case of a heavy internal fault, when an external source feeds current into the fault, the restraining currents are in opposite directions and the restraining torque tends to cancel out, as illustrated in Figure 1b.

When the currents fed from the two sides are equal, or effectively equal because of the taps used, the restraint is totally cancelled.

When effectively unequal currents flow in from the two sides, the restraint is equivalent to the difference in the two effective currents divided by two, but since the more sensitive operating coil is energized by the sum of the two currents the restraint in this case is inconsequential, and a large amount of contact-closing torque is produced.

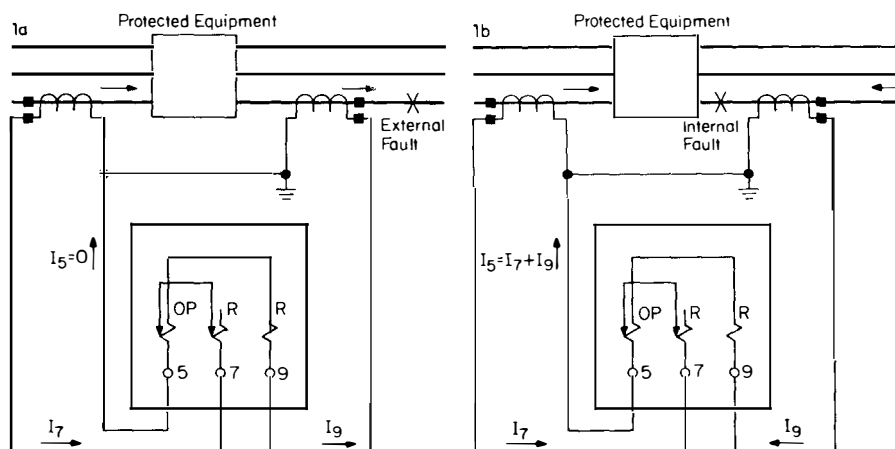

Figure 1: Typical External Connections for Type CA Relay.

182A885

Device Number: 87

Westinghouse

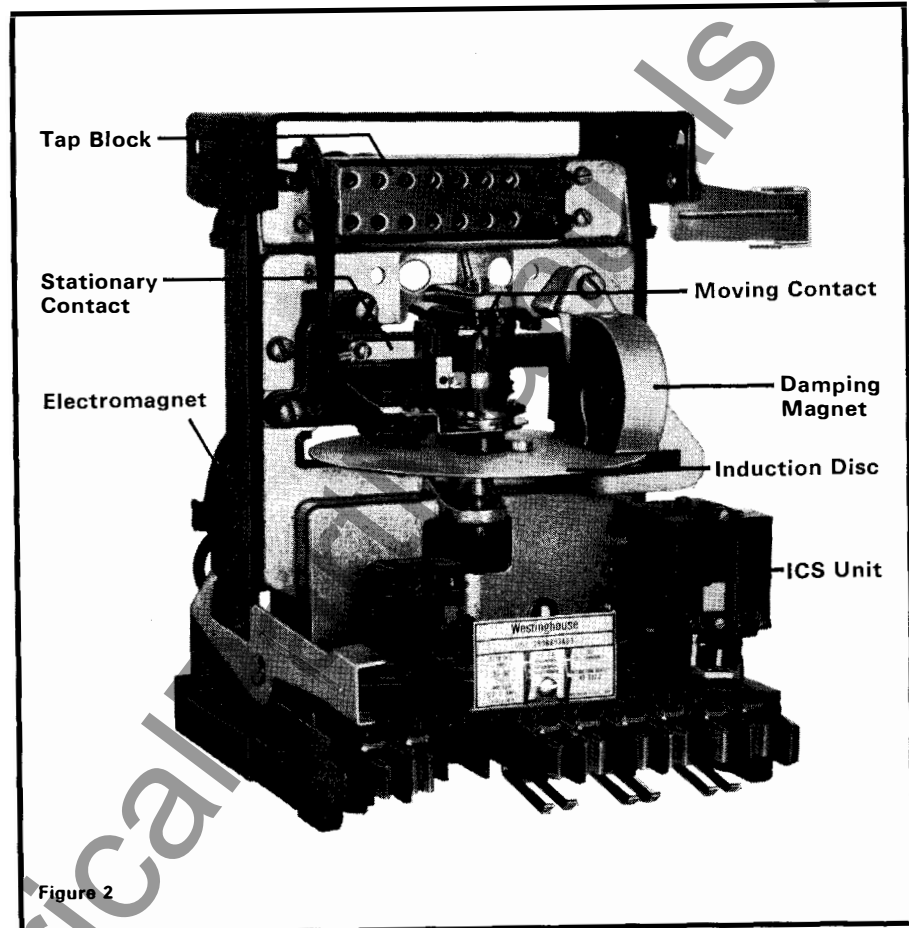

Figure 2

Construction

The CA relay consists basically of a percentage differential unit and an Indicating Contactor Switch (ICS).

Percentage Differential Unit

Induction disc type, with an electromagnet that has poles above and below the disc. Two restraint coils are located on the lower left-hand pole (front view), and an operating coil is wound on the lower right-hand pole.

Transformer windings on both left-hand and right-hand poles are connected in parallel to supply current to the upper pole windings. The upper pole current generates a flux which is in quadrature with the lower pole resultant flux, and the reaction of the two fluxes produces a torque on the disc. If the operating winding is energized, this torque is in the contact-closing direction. If current flows through the two restraining windings in the same direction, contact opening torque results.

Indicating Contactor Switch (ICS)

The dc Indicating Contactor Switch is a clapper type device in which a magnetic armature, with spring leaf contacts attached, is attracted to a magnetic core upon energization of the unit. When the switch closes, the moving contacts bridge two stationary contacts, thereby completing the trip circuit. Also during this operation, two fingers on the armature deflect a spring located on the front of the switch which allows a target to drop to indicate that operation has occurred. Resetting of the target is by means of a pushrod located outside the case at the bottom of the cover.

No setting is required on the ICS unit except selecting the 0.2 or 2.0 ampere tap. When the relay energizes a 125 or 250 volt dc type WL switch or equivalent, the 0.2 tap is used. For 48 volt dc applications, the 2.0 ampere tap should be utilized.

Type CA Single Phase Transformer Differential Relay

Internal Wiring (Front View) CA Transformer Relay in FT-21 Flexitest® Case

Notes:

1. Connect Terminal 7 to High Current, Terminal 9 to Low Current, and Terminal 5 to Common.
2. Terminals 5, 6, and 8 are to be jumpered at relay case.

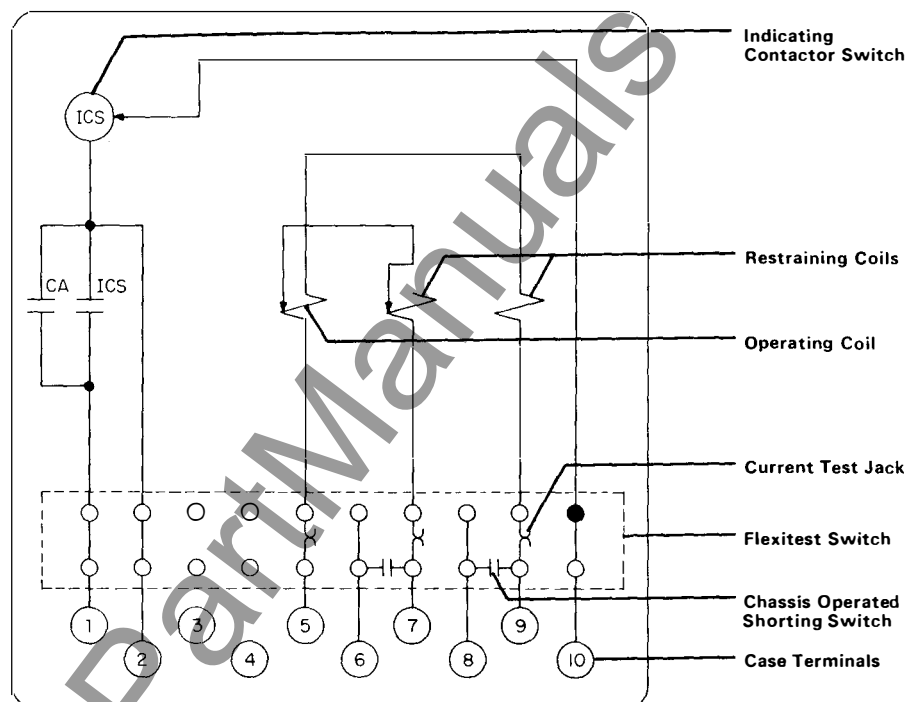

Figure 3

57D4554

Characteristics

Constant percentage differential.

Single phase, 60 hertz.

Spst-cc contacts.

Two restraint, one operating coil.

Restraint Circuits: 10 amperes, continuous (the untapped winding should be limited to 5 amperes, to prevent overloading of the operating winding).

Operating Circuit: 5 amperes, continuous.

Sensitivity: 50% unbalance.

Ratio Taps: 5-5, 5-5.5, 5-6, 5-6.6, 5-7.3, 5-8, 5-9, 5-10.

Minimum Trip: On 5-5 tap, terminals 9 and 5, 2.7 to 2.8 amperes.

On 5-5 tap, terminals 7 and 5, 2.9 to 3.2 amperes.

Inverse Time Characteristics: See Figure 10.

Burden: See Figures 8 and 9.

Operating Characteristics

The operating characteristics of the CA relay for normal through load current and

through fault current are shown in Figures 4 and 5. When the currents flowing into and out of the relay are plotted on these curves, if the point falls outside of the inoperative area, the relay will close its contacts.

In Figures 4 and 5 the two curves going with the 5-5 tap are tied together with a bracket to indicate that they go together. Similarly, the two curves for the 5-10 tap are also tied together. The center lines between pairs of curves are shown for all taps. The paired curves, bounding the inoperative areas, are not shown for all taps. These curves may be determined approximately by means of the following formulas:

$$\text{For the upper curve: } I_9 = \frac{7.5I_7}{T} \quad (1)$$

$$\text{For the lower curve: } I_7 = .3TI_9 \quad (2)$$

In these formulas, T is the larger number of the tap pair. For example, if the relay is used on the 5-7.3 tap, then T=7.3.

As an example of the degree of accuracy of the formula consider the point $I_7=43.5$, and $I_9=30$; read from the lower curve for the 5-5 tap, Figure 4. Applying the formula, equation (2), the calculated value of I_7 is found to be 45 amperes, which is fairly close to the curve value $I_7=43.5$.

The derivations of equations (1) and (2) are given in Figure 11, which has been included to illustrate the meaning of these equations.

Typical Time-Of-Operation curves are shown in Figure 10.

Figure 6 shows the operating curves for the relay with the restraining currents 180° out of phase. These curves also apply where current flows in only one restraining winding and the operating coil.

Relay Settings

To determine the correct tap setting (see Characteristics for available taps), calculate the currents delivered to the relay at full load on the transformer bank; taking into consideration not only the current transformer ratios but any delta connections which may be used, as well.

These currents will be in a certain ratio, and the taps on the relay should be chosen to match this ratio as closely as possible. For example, assume that the currents are 7.8 and 4.6 amperes, with the relay properly connected so that the higher current (7.8 amperes) flows in the tapped restraining winding. The ratio $4.67/7.8$ is equal to $5/8.47$. The nearest tap ratio of the relay is $5/8$, and this is the pair of taps that should be used. The time dial should be set on the number 1 position.

Westinghouse



Performance Curves

Typical Operating Curves, Low Current Values

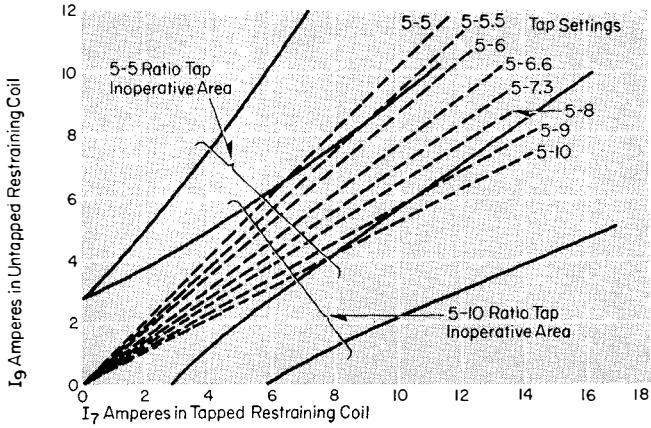

Figure 4

183A161

Typical Operating Curves, High Current Values

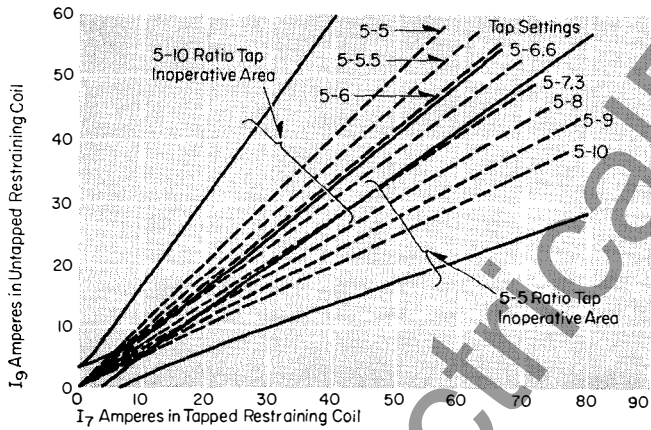

Figure 5

183A162

Typical Operating Curves, Restraint Currents 180° Out-Of-Phase

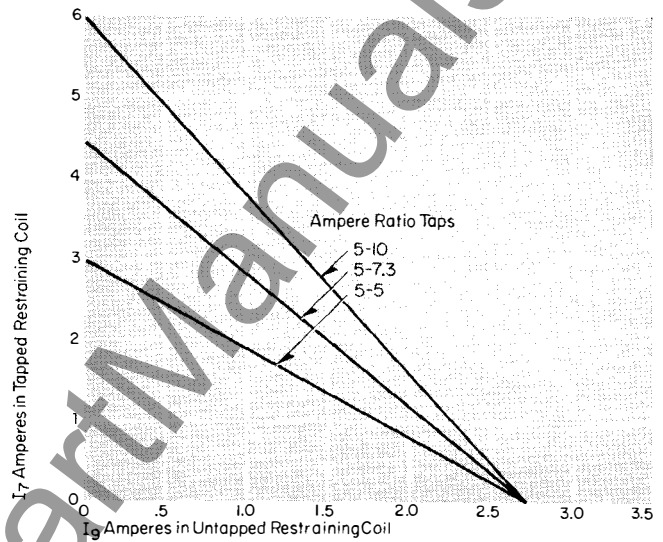

Figure 6

Typical Saturation Curves

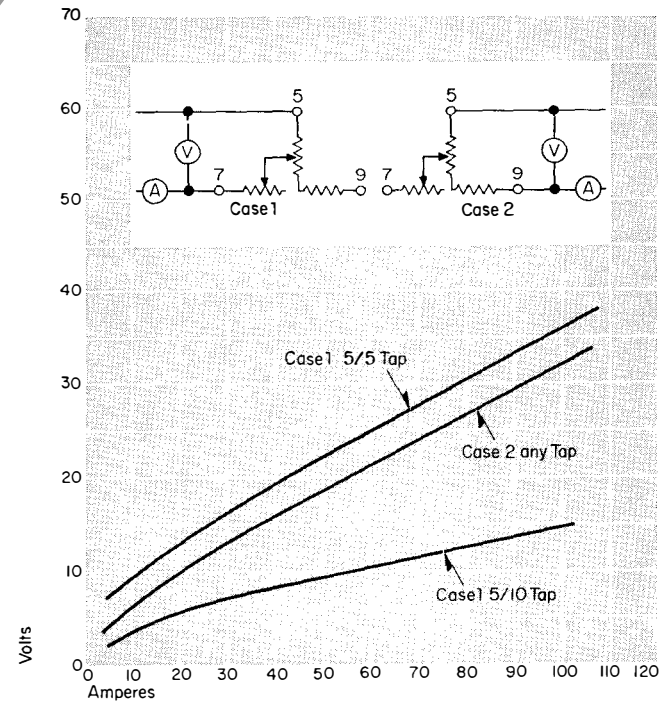

Figure 7

282267

Type CA Single Phase Transformer Differential Relay

Typical Burden Curves, 5-10 Taps ($I_5 = \frac{1}{2} I_7$)

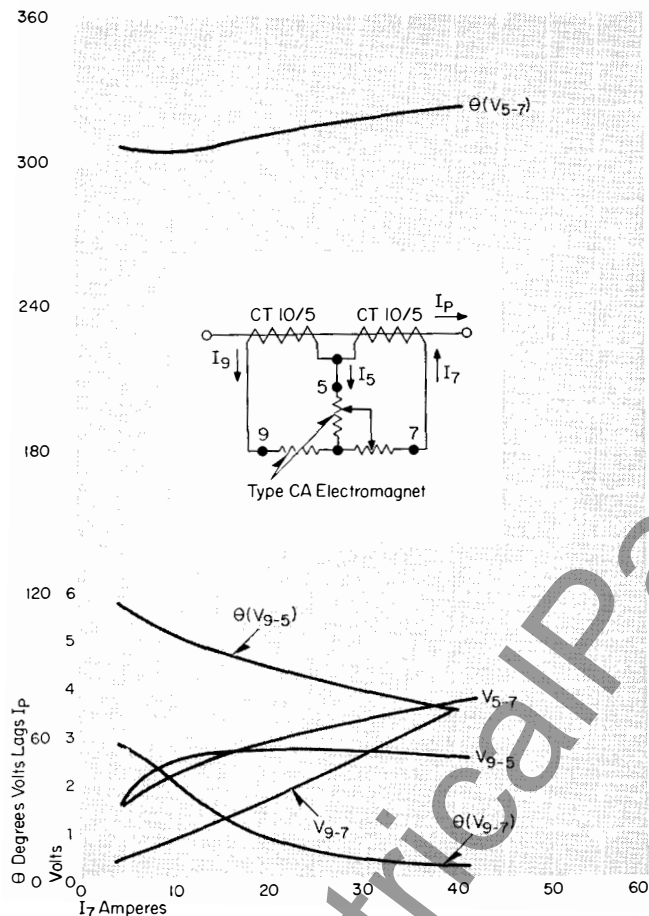

Figure 8 282373

Typical Burden Curves, 5-5 Taps ($I_5 = 0$)

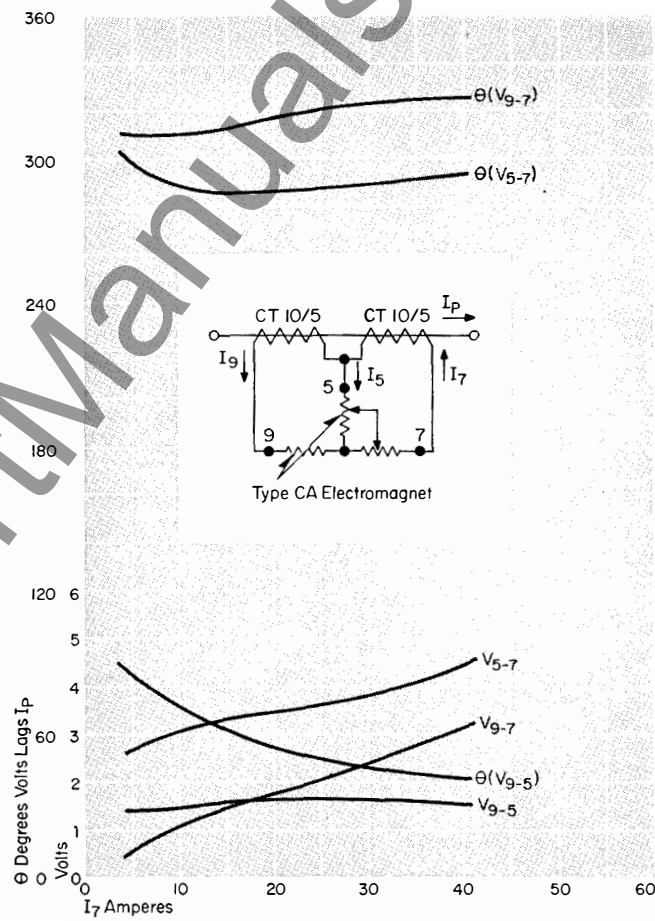

Figure 9 282372

Typical Time Curves

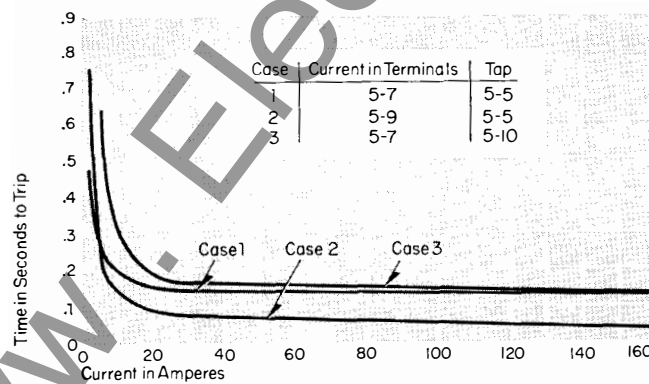

Figure 10 187A778

Fundamental Relationships In The Differential Unit

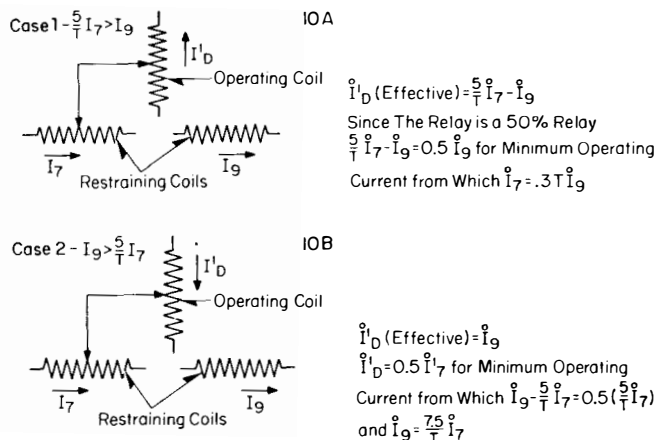
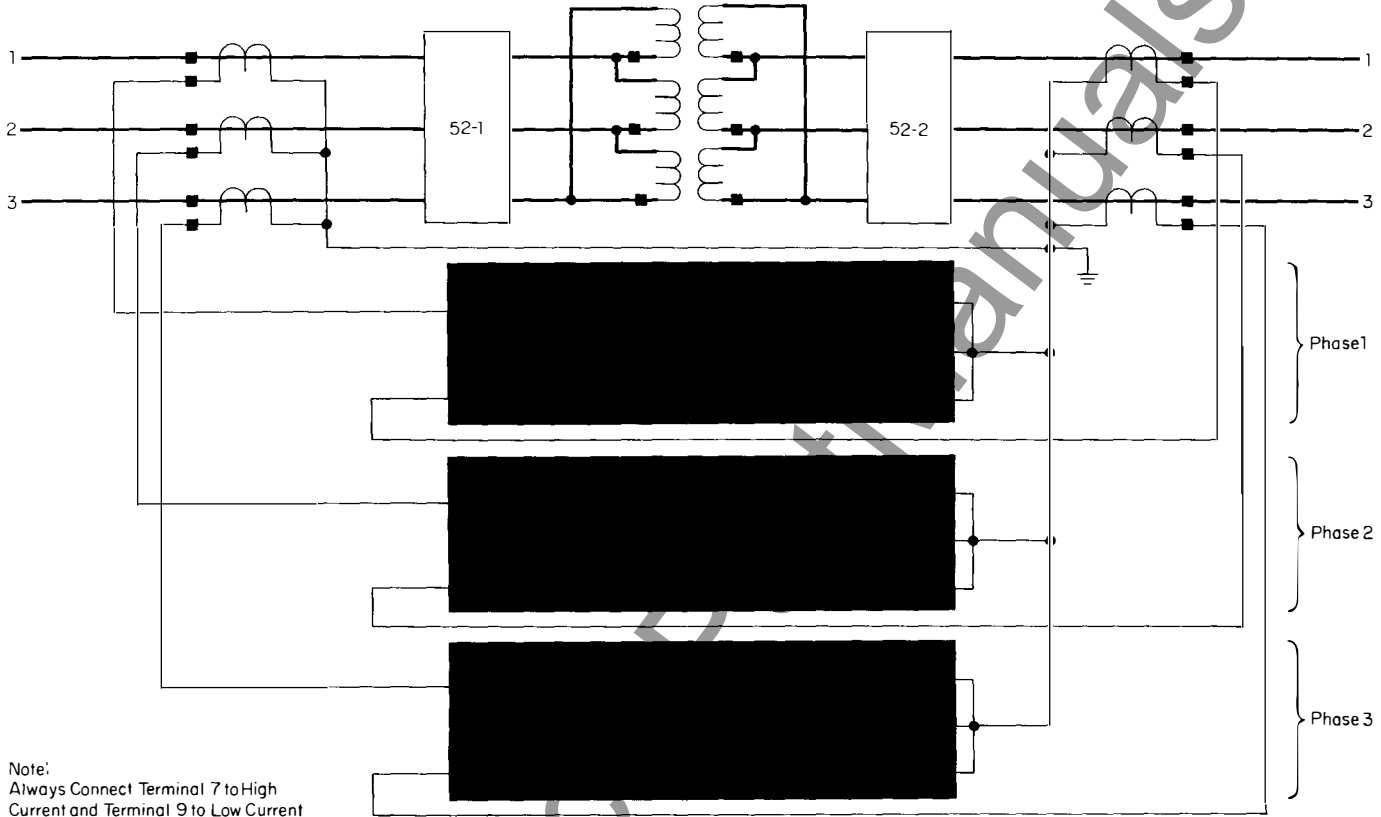

Figure 11

Westinghouse



**External Wiring
For Protection of a Delta-Delta Transformer Bank**



Note:
Always Connect Terminal 7 to High
Current and Terminal 9 to Low Current

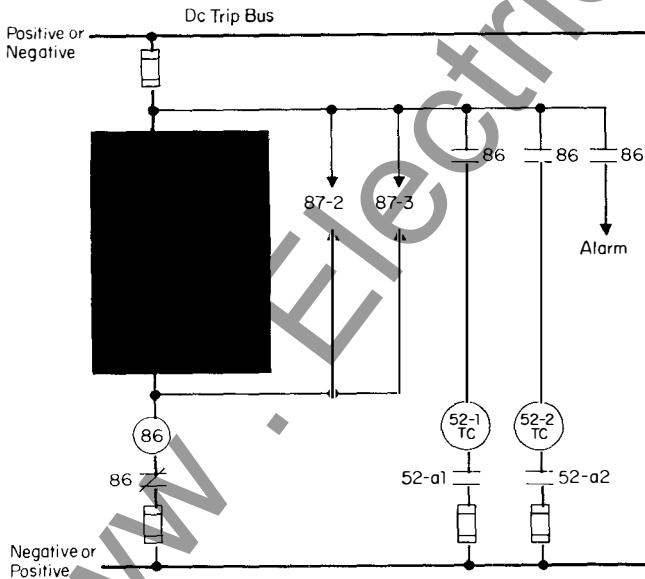

Device Numbers

- 87 – Transformer Percentage Differential Relay, Type CA
- 87R – Restraining Coil of Type CA Relay
- 870P – Operating Coil of Type CA Relay
- 86 – Auxiliary Tripping Relay, Type WL
- 52 – Power Circuit Breaker
- 52a – Breaker Auxiliary Contact
- 52TC – Breaker Trip Coil
- ICS – Indicating Contactor Switch

Note: Always Connect Terminal 7 to High Current and Terminal 9 to Low Current

Figure 12

Type CA Single Phase Transformer Differential Relay

For Protection of a Wye-Delta Transformer Bank

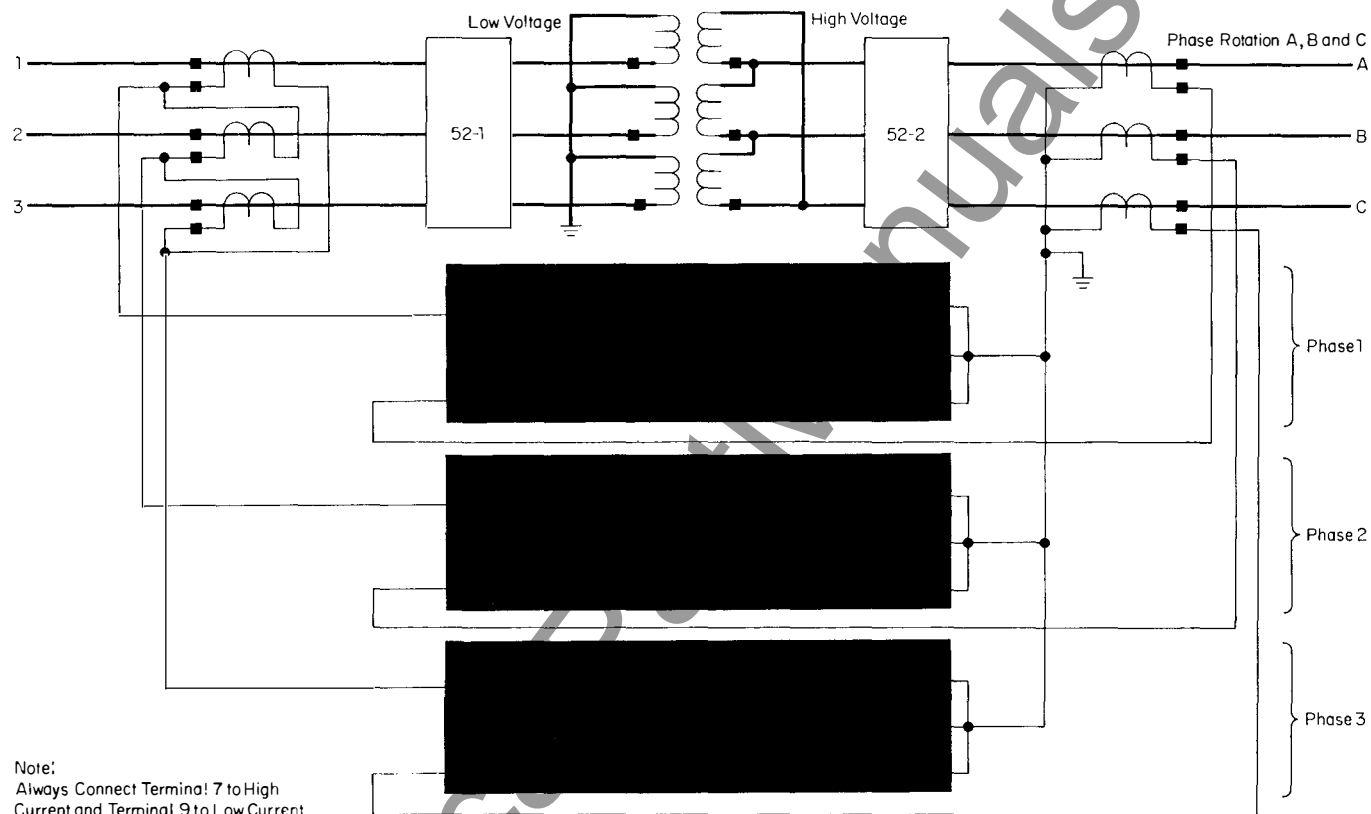

Note:
Always Connect Terminal 7 to High
Current and Terminal 9 to Low Current

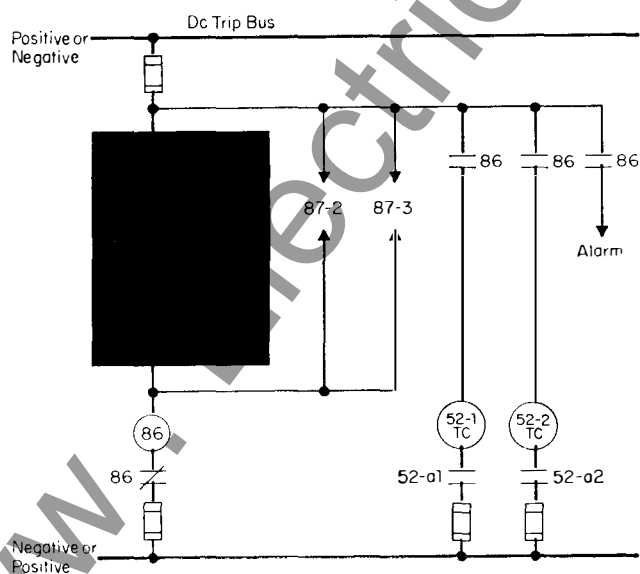

Device Number Chart

- 87 – Transformer Percentage Differential Relay, Type CA
- 87R – Restraining Coil of Type CA Relay
- 87OP – Operating Coil of Type CA Relay
- 86 – Auxiliary Tripping Relay, Type WL
- 52 – Power Circuit Breaker
- 52a – Breaker Auxiliary Contact
- 52TC – Breaker Trip Coil
- ICS – Indicating Contact Switch

Note: Always Connect Terminal 7 to High Current and Terminal 9 to Low Current

Figure 13

Type CA Single Phase Transformer Differential Relay

Standard Ratings (Single Phase, 60 Hertz)

Trip Contacts	Amperes Minimum Trip	Indicating Contactor Switch	Sensitivity	Case Size
Spst-cc Dpst-cc	2.75	0.2/2.0 dc	50%	FT-21

Further Information

Application: Application Data 41-300

Prices: Price List 41-020

Flexitest Case Dimensions: Descriptive Bulletin
41-075

Instructions: Instruction Leaflet 41-332.2

Other Protective Relays: Selector Guide 41-000