



January, 1978
Supersedes A.D. 38-727 pages 1-2,
dated October 1977

Relay and Static Control
15.5-38 Kv, 800 Amperes
110, 125, or 150 Kv BIL

Mailed to: E, D, C/1994/DB

Three-Phase Automatic Vacuum Recloser Type ESV

Selection and Application

The Westinghouse automatic vacuum circuit recloser provides three-phase overcurrent protection for both substation and line application. The recloser uses oil as a dielectric in order to minimize space. This application data divides the complete recloser into three separate components for discussion:

1. The recloser which consists of the high voltage components and stored energy mechanism.
2. The control- Westinghouse type CO overcurrent relays or MTR static control.
3. The frame, either adjustable substation frame or pole-type mounting frame, and the tank lifting windlass.

Selection Step 1 – Recloser Continuous Current and Interrupting Rating

Select recloser catalog number from Table 1 below.

Description – The recloser high voltage components and mechanism consist of the following:

- Aluminum top casting – The top casting supports the bushings with the vacuum interrupters.
- High-voltage oil-filled compartment
The tank is constructed of fabricated steel. The gasket between top casting and the tank prevents entrance of moisture. Venting is not required since no arcing occurs outside the vacuum envelope.

- Oil drain, sample valve, and visual floating ball oil level indicator.
- Stored energy trip and close mechanism.
- Operations counter and main contact position indicator.
- Manual close pushbutton – The stored energy mechanism permits the recloser to be closed into a faulted line without damage.
- External manual trip lever.

Table 1 Specific Ratings and Catalog Number

Catalog Number	ESV 1512	ESV 2710	ESV 2712	ESV 3806	ESV 3810
Rated Maximum Voltage kV, Grounded Wye Systems	15.5	27	27	38	38
Continuous Current Amps	800	800	800	800	800
Basic Impulse Level Withstand Voltage kV (BIL)	110	125 or 150 ^①	125 or 150 ^①	150	150
Maximum Interrupting Capacity RMS Symm. Amps ^②	12,000	10,000	12,000	6,000	10,000
60 Hertz, One Minute Withstand, Dry, kV RMS	50	60/70 ^③	60/70 ^③	70	70
60 Hertz, Ten Second Withstand, Wet, kV RMS	45	50/60 ^③	50/60 ^③	60	60
Temperature Range	-30°C to +70°C	-30°C to +70°C	-30°C to +70°C	-30°C to +70°C	-30°C to +70°C
Minimum Close Time, Cycles	25	25	25	25	25
Minimum Interrupting Time, Cycles	3.5	3.5	3.5	3.5	3.5

^① BIL determined by bushing selected.

^② Interrupting capacity is not a function of phase or ground minimum trip selection.

^③ Higher values apply to 150 kV BIL design.

Selection Step 2 – High Voltage Bushings and Terminals

Description

High voltage bushings for the type ESV recloser are of bulk porcelain construction. Terminals supplied are either a NEMA 4-hole flat pad or a 4 bolt clamp type for 2/0 through 800 MCM conductor. All bushings are ASA 70 Grey.

Selection Step 3 – Bushing Current Transformers and Auxiliary Switch

Description

Each relayed recloser uses a set of three (600/5 or 1200/5) multi-ratio (5 lead) bushing current transformers to provide overcurrent sensing and auxiliary functions such as driving thermal demand ammeters. The recloser with the MTR static control uses a set of three (1000/5) bushing current transformers to provide overcurrent sensing. Bushing current transformers (2 sets maximum) are mounted on bushings 2-4 and 6. Leads from the BCT's are terminated in the low voltage mechanism compartment with Penn Union 6006-SC short circuiting type terminal blocks. Each recloser requires 3 "A" and 3 "B" contacts to operate the control circuit. One "A" and one "B" (field changeable) are provided for customer use. (For additional contacts see Selection Step 14.)

Selection Step 4 – Trip Coil Voltage and Trip Potential Source

Each recloser requires a shunt trip coil. Selection depends upon trip source specified by the user. The users trip control voltage and trip coil voltage must be the same (except when the capacitor trip device or battery trip device is specified). The trip coils will operate from the following sources:

- 24 VDC NiCad battery and battery charger – internal source
- Capacitor trip device – internal source
- 48 or 125 VDC – external source
- 240 VAC – external source

Bushing Electrical Characteristics and Catalog Number

Creep In.	Strike In.	BIL	Recloser Type	Outline Drawing	Terminal	Catalog Number
27.5	10.75	125 Kv	ESV	6483A96	Clamp #2 – 800 MCM	ESV 27C
27.5	10.75	125 Kv	ESV	6483A97	NEMA 4 Hole Pad	ESV 27P
30.5	15.75	150 Kv	ESV	6483A98	Clamp #2 – 800 MCM	ESV30C
30.5	15.75	150 Kv	ESV	6483A99	NEMA 4 Hole Pad	ESV30P

Bushing Current Transformer Technical Data and Catalog Number

600/5, Accuracy Class C100, Curve 511800										
Current Ratio	600/5	500/5	450/5	400/5	300/5	250/5	200/5	150/5	100/5	50/5
Turns Ratio	120:1	100:1	90:1	80:1	60:1	50:1	40:1	30:1	20:1	10:1
1200/5, Accuracy Class C200, Curve 511801										
Current Ratio	1200/5	1000/5	900/5	800/5	600/5	500/5	400/5	300/5	200/5	100/5
Turns Ratio	240:1	200:1	180:1	160:1	120:1	100:1	80:1	60:1	40:1	20:1
Secondary Trips	X2-X3	X1-X2	X1-X3	X4-X5	X3-X4	X2-X4	X1-X4	X3-X5	X2-X5	X1-X5

Catalog Number – Bushing Current Transformer

Quantity and Ratio	For Use with Control Shown	Mechanism	Cabinet	Connection Diagram	Catalog Number
3-600/5	Relay	1885B14			3CT6V
3-1200/5	Relay	1885B16			3CT12V
6-600/5	Relay	1885B15			6CT6V
6-1200/5	Relay	1885B17			6CT12V
3-600/5 and 3-1200/5	Relay	1885B18			6CT612V
3-1000/5	Static	1885B19			3CT10V
3-1000/5 and 3-600/5	Static	1885B20			6CT610V
3-1000/5 and 3-1200/5	Static	1885B21			3CT112V

- Note 1:** Maximum of 2 sets of BCT's may be specified (6 BCT's/recloser).
- Note 2:** By selecting catalog numbers for BCT's, the mechanism connection diagram is also selected. This diagram shows the BCT connections and compartment 25 watt, 240 VAC space heater.

Note 3: Ammeters or thermals from accessories, page 8, require 600/5 or 1200/5 BCT's. Size 2 (G03 or G04) cabinet is also required when ammeters or thermals are specified.

Selection Step 5 – Stored Energy Charging Motor

Description

Each recloser is supplied with a spring trip, spring close mechanism. The mechanism requires a 240 VAC motor to charge the closing springs.

Charge Motor Technical Data and Catalog Number

Catalog Number	Voltage	Locked Rotor Amps	Charge Amps
23ACEG01	Nominal 240 VAC Range 208-254 VAC	6	3

Trip Coil Technical Data and Catalog Number

Voltage	Trip Amps	Voltage Range	Catalog Number
24VDC	4.0	14-28	TCE24G01
48 VDC	2.6	28-56	TCE48G01
125 VDC	5.0	70-140	TCE125G01
240 VAC	1.9	208-254	TCE230G01
Cap. Trip Device Coil	3.7	Ref. IL 38721-5	CTDEG02

- Note 1:** When internal battery trip device (Step 12) is selected specify TCE24G01 24 VDC trip coil.
- Note 2:** TCE230G01 or TCE24G01 are standard for static control; however, any tripping source can be used.



Selection Step 6 – Substation Type Mounting Frame and Control Cabinet Location

Description

All substation mounting frames are constructed from 3 in x 3 in x 3/16 in galvanized steel. All frames are adjustable height and include provisions for user grounding.

Note 1: A size 2, G03, frame and cabinet can be supplied on static controlled reclosers where a larger cabinet is required; however, the connection between the control cabinet and the recloser mechanism cabinet will be hard wiring.

Note 2: The size one cabinet (G05) is the standard substation frame and cabinet for a static controlled recloser. If metering accessories from page 8 are specified, the size 2 cabinet (either the G03 or G04 frame) must be specified depending on whether or not the convenience of a plug connection is required.

Note 3: A size 3 cabinet may be required if several accessories are specified. No catalog numbers apply.

Frame Catalog Number for ESV Recloser	Normally Used With Listed Control	Cabinet Size	Cabinet Position Bushing 1, 3, and 5 To Front	Wiring Method Between Control Cabinet and Mechanism Cabinet	Outline Drawing
ESVSG03	Relay	2	Front Recessed	Hard Wire	6483A90
ESVSG04	Static	2	Front Recessed	Amphenol plugs	6483A90
ESVSG05	Static	1	Front Recessed	Amphenol plugs	6483A91
ESVSRG03	Relay	2	Rear Mounted	Hard Wire	6483A92
ESVSRG04	Static	2	Rear Mounted	Amphenol plugs	6483A92
ESVSRG05	Static	1	Rear Mounted	Amphenol plugs	6483A93
ESVSLG03	Relay	2	Left Side	Hard Wire	6483A94
ESVSLG04	Static	2	Left Side	Amphenol plugs	6483A94
ESVSLG05	Static	1	Left Side	Amphenol plugs	6483A95

Selection Step 7 – Tank Lifting Windlass For Substation Mounted Type ESV Reclosers

Description

A winch type tank lifter and the necessary pulleys and cable are supplied so that the user may lower the oil tank for inspection.

Catalog Number	For Use With Type Recloser	Outline Drawing
TLSG02	ESV All Ratings	6485A24

Selection Step 8 – Pole Type Mounting Frames For Direct Pole Mounting

Description

The direct pole mounting frame is constructed with 3 in x 3 in x 3/16 in galvanized steel. Frames with tanklifters include a gear box type tank lifter, and the necessary pulleys and cables so the user may lower the oil tank for inspection.

Catalog Number	For Use With Type Recloser	Outline Drawing
ESVPG01	Relayed ESV with Size 2 Cabinet without tanklifter ^①	6484A87
ESVPG02	Static ESV with Size 1 Cabinet without tanklifter ^①	6484A87
ESVPLG01	Relayed ESV with Size 2 Cabinet with tanklifter	6485A15
ESVPLG02	Static ESV with Size 1 Cabinet with tanklifter	6485A15

^① Tanklifters cannot be added to this design.

Selection Step 10 – Control Cable Assembly For Use With Pole Mounted Reclosers

Description

Each recloser and control cabinet are connected together via a multi-conductor control cable. For pole mounted type ESV reclosers the user must specify the length of cable required. The control cable enters the recloser mechanism cabinet through a multi-conductor plug and jack. Control cable selection is not required for substation mounted units.

Catalog Number	Length of Control Cable (Feet) ^①
CA5G01	5
CA10G01	10
CA15G01	15
CA20G01	20
CA25G01	25
CA30G01	30
CA35G01	35
CA40G01	40

^① Actual length of the cable is length shown plus 5 ft. for slack.

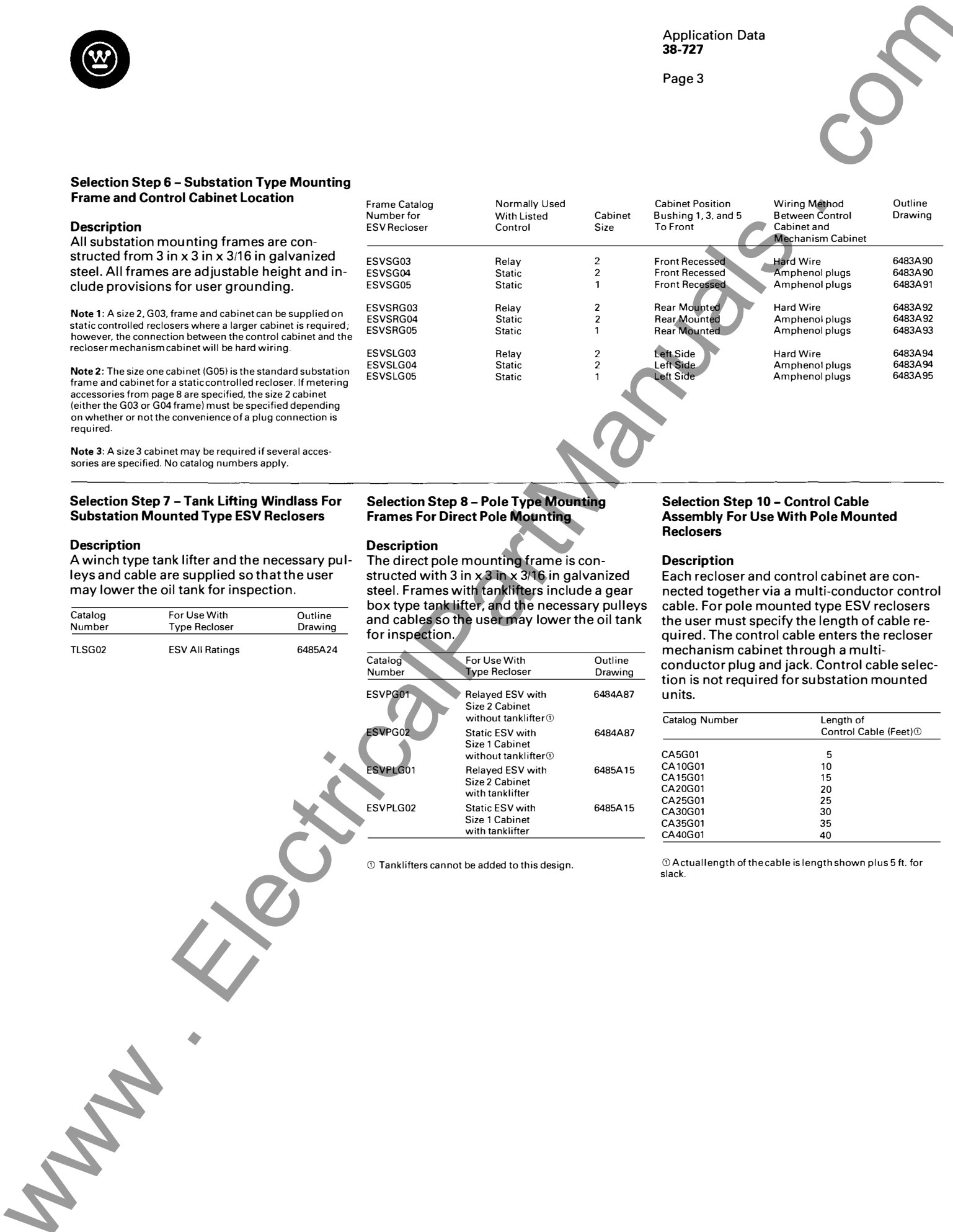

Selection Step 11 – Relay Control For Either Substation or Pole Mounted Reclosers

Description

Recloser applications may be simplified through use of Westinghouse Type CO overcurrent relays for phase and ground protection. Westinghouse Type CO relays provide an infinite number of time delay trip curves and when combined with the multi-ratio bushing current transformer provide the user with many values of phase and ground minimum trip settings without the purchase of any other components. For complete curve shapes, time delay current ranges, and instantaneous current ranges refer to Westinghouse Performance Data 41-000 and DB 41-100A.

Control Cabinet Description

The relay size 2 control cabinet is mounted on the substation frame (See Selection Step 6 for location) or provided with pole mounting brackets in the case of a pole mounted unit. All relays and controls are mounted on a hinged front panel for easy access. Each relay control package is supplied with the following equipment as standard.

- Control switch with red and green indicating lights.
- Fuse for control circuit protection.
- Non-reclose switch.
- 25 watt, 230 VAC control cabinet heater.
- Necessary terminal blocks and control wiring.

Relay Selection

The relay control package may be supplied with two phase and one ground relay, three phase relays and no ground relay, or three phase relays and one ground relay. The phase and ground relays may be supplied with or without a fast trip feature. Each relay and its associated fast trip relay contain "targets" to indicate which phase has "seen" a fault. Each relay is mounted in a Westinghouse Flexi-test case to permit quick removal for inspection and maintenance. The control scheme requires circuit closing (CC) type relays. Refer to DB 41-000 or Table 4, page 7, for style number selection.

The use of two phase and one ground relays, three phase relays and no ground relay, or three phase relays and one ground relay depend upon the application and/or user preference. The following table is designed to show the tripping sequence for various combinations of fault conditions.

Typical BCT-Relay Connections For Grounded Wye Systems

3 Phase Relays and 1 Ground Relay

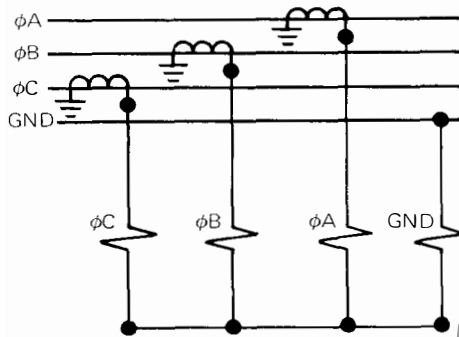

2 Phase Relays and 1 Ground Relay

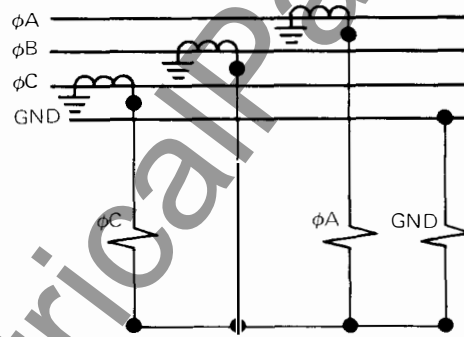

3 Phase Relays and No Ground Relay

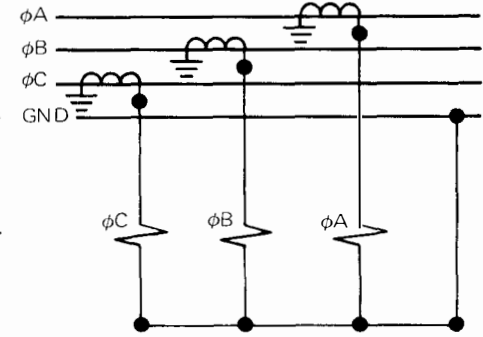

Type of Fault	3 Phase Relays and 1 Ground Relay		2 Phase Relays and 1 Ground Relay		3 Phase Relays and No Ground Relay	
	Primary Trip Relay	Back-Up Trip Relay	Primary Trip Relay	Back-Up Trip Relay	Primary Trip Relay	Back-Up Trip Relay
⊗A-GND	GND	⊗A	GND	⊗A	⊗A	—
⊗B-GND	GND	⊗B	GND	—	⊗B	—
⊗C-GND	GND	⊗C	GND	⊗C	⊗C	—
⊗A-⊗B	⊗A or ⊗B	⊗B or ●A	●A	—	●A or ⊗B	●B or ●A
⊗A-⊗C	●A or ●C	⊗C or ●A	⊗A or ⊗C	⊗C or ●A	●A or ●C	⊗C or ●A
⊗C-⊗B	⊗C or ⊗B	⊗B or ⊗C	⊗C	—	●C or ●B	●B or ●C
●A & ●B-GND	GND	●A or ●B	GND	⊗A	●A or ●B	●B or ●A
●A & ⊗C-GND	GND	⊗A or ●C	GND	⊗A or ●C	●A or ⊗C	●C or ●A
●B & ●C-GND	GND	●B or ●C	GND	●C	⊗B or ●C	●C or ●B
●A, ●B, ⊗C-GND	GND	●A or ●B or ⊗C	GND	●A or ●C	●A or ●B or ●C	●C or ●B or ●A

Note 1: The above table is designed to illustrate a general case. Actual primary and back-up tripping depend upon relay co-ordination, fault current magnitude, and symmetry.



Reclose Relay Selection

The relay control package may be supplied with either the Type RCS-II or Type EMI reclose relay. Selection depends upon application and/or user preference. The reclose relay (RCS-II or EMI) is the device that controls the following functions:

- Number of tripping operations to lock out.
- Number and sequence of fast and time delay trips.
- Reset time.

Figure 1 shows a typical sequence of tripping and reclosing of the recloser main contacts. In this example the control is set for four operations to lock out.

Reset Time

Both the RCS-II and EMI reclose relays have the reset after reclose feature. The reset timer begins upon reclose as shown in Figure 2. This feature allows a shorter reset time. Reset time need only be coordinated with maximum trip time at minimum trip setting.

To describe the operation, assume the recloser is locked out and the fault still exists. Operate control switch to close recloser. The recloser will operate on the last selected trip curve. In most cases this will be a time delay operation. After the reset time, the control will reset to its programmed operational sequence.

Load Current Metering

To aid the user in feeder loading, the relay control package may be supplied with Sangamo thermal demand meters or indicating ammeters. All relay control packages include panel knock out and terminals for easy installation of meters in the field or factory.

Capacitor Trip Device

The capacitor trip device consists of a capacitor and rectifier network to provide a DC potential to the trip coil. The capacitor trip device maintains a constant DC potential for tripping during control voltage fluctuations. If the control voltage is lost, the capacitor trip device will maintain tripping voltage for 60 seconds. Refer to IL-38-721-5 for schematic. Style number of the capacitor trip device is 804B158G01.

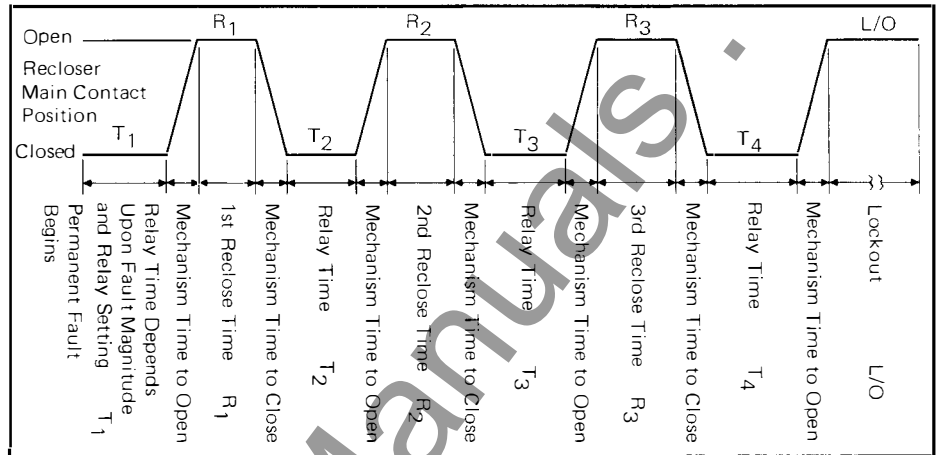

Figure 1

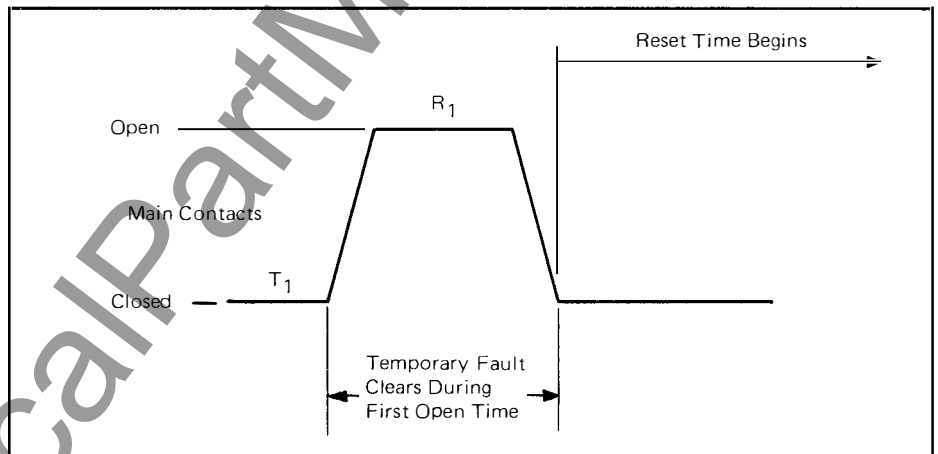

Figure 2

Comparison of Type RCS-II and EMI Reclose Relay Features

Function	Reclose Relay	
	RCS-II	EMI
Trips to lockout	1, 2, 3 or 4	1, 2, 3 or 4
Number of fast trips	0, 1, 2, 3 or 4	0, 1, 2, 3 or 4
Reset time	Adjustable 25-120 sec.	Adjustable 0-390 sec.
Reclose time range		
First reclose time R ₁	Instantaneous or 5-60 sec. ①	Instantaneous or 5-57 sec. ②
Second reclose time R ₂	5-60 sec. ① ③	5-57 sec. ② ③
Third reclose time R ₃	5-60 sec. ① ③	5-57 sec. ② ③
Instruction Book Number	IL-38-721-4	IL-38-741
Schematic	237C164	3871A77

① Reclose times R₁, R₂ & R₃ are independent of each other in the RCS-II relay.

② Reclose times R₁, R₂ & R₃ are the same in the EMI relay unless R₁ is set for instantaneous reclose, then R₂ and R₃ must be identical times.

③ 5 seconds is the minimum reclose time for the second and third reclose times on both the RCS-II and EMI relays. This time allows the motor to charge the close springs.

Relay Control Catalog Numbers, Schematics, and Connection Diagrams

The following tables have been prepared to aid the use in selecting a relay package. Every combination of relays, CTD, BTD and meters

has been identified by a catalog number. This catalog number specifies the schematic and wiring diagram.

Table 1 – 2 Phase Relays and 1 Ground Relay

2 Phase Relays and 1 GND Relay	Provisions for Meters	Sangamo Triplex Thermal Demand Ammeters	Type GA 0-5 Amp Indicating Ammeters	RCS-II Reclose Relay	EMI Reclose Relay	Trip Circuit Voltage ● 48 VDC, 125 VDC External Source ● 24 VDC BTD Internal Source. Note: Battery trip device BTD must be specified as a separate item			Trip Circuit Voltage ● 230 VAC External Source			Trip Circuit Voltage ● Internal CTD		
						Catalog ^① Number	Schematic Diagram	Wiring Diagram	Catalog ^① Number	Schematic Diagram	Wiring Diagram	Catalog ^① Number	Schematic Diagram	Wiring Diagram
●	●	●	●	●	●	CC301	5966C01	5966C02	CC307	5966C05	5966C06	CC313	5966C09	5966C10
●	●	●	●	●	●	CC302 ^②	5966C01	5966C02	CC308 ^②	5966C05	5966C06	CC314 ^②	5966C09	5966C10
●	●	●	●	●	●	CC303	5966C01	5966C02	CC309	5966C05	5966C06	CC315	5966C09	5966C10
●	●	●	●	●	●	CC304	5966C03	5966C04	CC310	5966C07	5966C08	CC316	5966C11	5966C12
●	●	●	●	●	●	CC305 ^②	5966C03	5966C04	CC311 ^②	5966C07	5966C08	CC317 ^②	5966C11	5966C12
●	●	●	●	●	●	CC306	5966C03	5966C04	CC312	5966C07	5966C08	CC318	5966C11	5966C12

① When entering orders, the style number of the phase and ground relays must be specified as well as the catalog number of the control.

② The style number of the thermal demand ammeter must be specified: 402A869H04 ADH-2 without instantaneous attachment, or 402A869H09 ADH-2 with instantaneous attachment, 0-5 amp scale.

Table 2 – 3 Phase Relays and No Ground Relay

3 Phase Relays and No GND	Provisions for Meters	Sangamo Triplex Thermal Demand Ammeters	Type GA 0-5 Amp Indicating Ammeters	RCS-II Reclose Relay	EMI Reclose Relay	Trip Circuit Voltage ● 48 VDC, 125 VDC External Source ● 24 VDC BTD Internal Source. Note: Battery trip device must be specified as a separate item			Trip Circuit Voltage ● 230 VAC External Source			Trip Circuit Voltage ● Internal CTD		
						Catalog ^① Number	Schematic Diagram	Wiring Diagram	Catalog ^① Number	Schematic Diagram	Wiring Diagram	Catalog ^① Number	Schematic Diagram	Wiring Diagram
●	●	●	●	●	●	CC319	5966C13	5966C14	CC325	5966C17	5966C18	CC331	5966C21	5966C22
●	●	●	●	●	●	CC320 ^②	5966C13	5966C14	CC326 ^②	5966C17	5966C18	CC332 ^②	5966C21	5966C22
●	●	●	●	●	●	CC321	5966C13	5966C14	CC327	5966C17	5966C18	CC333	5966C21	5966C22
●	●	●	●	●	●	CC322	5966C15	5966C16	CC328	5966C19	5966C20	CC334	5966C23	5966C24
●	●	●	●	●	●	CC323 ^②	5966C15	5966C16	CC329 ^②	5966C19	5966C20	CC335 ^②	5966C23	5966C24
●	●	●	●	●	●	CC324	5966C15	5966C16	CC330	5966C19	5966C20	CC336	5966C23	5966C24

① When entering orders, the style number of the phase relays must be specified as well as the catalog number of the control.

② The style number of the thermal demand ammeter must be specified: 402A869H04 ADH-2 without instantaneous attachment, or 402A869H09 ADH-2 with instantaneous attachment, 0-5 amp scale.

Table 3 – 3 Phase Relays and 1 Ground Relay

3 Phase Relays and 1 GND Relay	Provisions for Meters	Sangamo Triplex Thermal Demand Ammeters	Type GA 0-5 Amp Indicating Ammeters	RCS-II Reclose Relay	Remote Trip and Close	EMI Reclose Relay	Trip Circuit Voltage ● 48 VDC, 125 VDC External Source ● 24 VDC BTD Internal Source. Note: Battery trip device must be specified as a separate item			Trip Circuit Voltage ● 230 VAC External Source			Trip Circuit Voltage ● Internal CTD		
							Catalog ^① Number	Schematic Diagram	Wiring Diagram	Catalog ^① Number	Schematic Diagram	Wiring Diagram	Catalog ^① Number	Schematic Diagram	Wiring Diagram
●	●	●	●	●	●	●	CC337	5966C25	5966C26	CC343	5966C29	5966C30	CC349	5966C33	5966C34
●	●	●	●	●	●	●	CC338 ^②	5966C25	5966C26	CC344 ^②	5966C29	5966C30	CC350 ^②	5966C33	5966C34
●	●	●	●	●	●	●	CC339	5966C25	5966C26	CC345	5966C29	5966C30	CC351	5966C33	5966C34
●	●	●	●	●	●	●	CC340	5966C27	5966C28	CC346	5966C31	5966C32	CC352	5966C35	5966C36
●	●	●	●	●	●	●	CC341 ^②	5966C27	5966C28	CC347 ^②	5966C31	5966C32	CC353 ^②	5966C35	5966C36
●	●	●	●	●	●	●	CC342	5966C27	5966C28	CC348	5966C31	5966C32	CC354	5966C35	5966C36
●	●	●	●	●	●	●			CC358	5966C39	5966C40	CC355	5966C37	5966C38	
●	●	●	●	●	●	●			CC359 ^②	5966C39	5966C40	CC356 ^②	5966C37	5966C38	
●	●	●	●	●	●	●			CC360	5966C39	5966C40	CC357	5966C37	5966C38	

① When entering orders, the style number of the phase and ground relays must be specified as well as the catalog number of the control.

② The style number of the thermal demand ammeter must be specified: 402A869H04 ADH-2 without instantaneous attachment, or 402A869H09 ADH-2 with instantaneous attachment, 0-5 amp scale.



com

Stock Relays

In order to provide short shipment, certain overcurrent relays are stocked at Bloomington. A listing is provided to aid the purchaser in specifying a recloser using stock relays.

Table 4 – Over Current Relays

Type	Current Range Amps: AC		Time Curve	Contacts	Indicating Contact Switch	Style Number
	Time Unit	Instantaneous Unit IIT				
CO-8	0.5-2.5	2-48	Inverse	Spst	0.2/2.0 Amp dc	264C900A03
CO-8	1-12	None	Inverse	Spst	0.2/2.0 Amp dc	264C900A05
CO-8	1-12	6-144	Inverse	Spst	0.2/2.0 Amp dc	264C900A07
CO-9	4-12	16-32	Very Inverse	Spst	0.2/2.0/2 ICS	183A805A28
CO-9	0.5-2.5	None	Very Inverse	Spst	0.2/2.0 Amp dc	264C901A01
CO-9	0.5-2.5	2-48	Very Inverse	Spst	0.2/2.0 Amp dc	264C901A03
CO-9	1-12	None	Very Inverse	Spst	0.2/2.0 Amp dc	264C901A05
CO-9	1-12	6-144	Very Inverse	Spst	0.2/2.0 Amp dc	264C901A07
CO-11	0.5-2.5	2-48	Extremely Inverse	Spst	0.2/2.0 Amp dc	265C047A03
CO-11	1-12	6-144	Extremely Inverse	Spst	0.2/2.0 Amp dc	265C047A07

Selection Step 12 – Battery Trip Device

A battery trip device may be selected. The battery trip device consists of a 24 VDC Ni-CAD battery and a 230 VAC potential type battery charger.

Catalog Number	Description
BTDG01	Battery trip device for use with control catalog numbers CC301-CC306, CC319-CC324, and CC337-CC342. Connection Diagram 3889A99

3) will give the customer a total of six extra "A" or "B" contacts. All "A" or "B" contacts are field changeable from "A" to "B" or "B" to "A". The contacts are terminated in the mechanism compartment.

Catalog Number	Description
AUX3G02	Westinghouse Style No. 46A5916G01 A total of 4 contacts either "A" or "B"

Selection Step 13 – Remote Trip and Close

Description

All relayed control packages are wired for user addition of a remote trip and close function, except control catalogs CC-355-360 which are furnished with all the local equipment wired at the factory.

This accessory includes the following loose and unmounted material that the user must mount in the recloser control cabinet if a control other than CC355-360 is specified.

- 628A271H07 Latch Relay
- 161A833H07 Remote/Local Switch
- 158P987H01 Remote/Local N/P

In addition – a 505A714G01 Remote Switch is supplied for remote mounting by the user.

Note – this option requires 230 VAC power. If other voltages, see Accessories 10 and 11, page 4, of PL 38-720.

Catalog Number	Description
STCG01	Remote trip and close, loose and unmounted for 230 VAC remote power operation only on controls other than CC-355-360

Selection Step 14 – Extra Auxiliary Switches

Description

A total of four extra "A" or "B" contacts may be added for exclusive customer use. This accessory combined with the standard two extra "A" or "B" contacts (see Selection Step

Selection Step 15 – Type MTR Static Control for Either Substation or Pole Mounted Reclosers

Description

Panel Construction

The front panel of the static control is neatly designed and clearly marked to afford ease in making changes in the coordination of the recloser as system demands vary.

The major components of the static control are:

- Static Phase Protection Unit
- Static Ground Fault Unit
- Faulted Phase Indicator Unit
- Ground Fault Indicator Unit
- Remote Trip and Close Unit

The features of each major component are described below.

Static Phase Protection Unit

This unit provides conventional three phase overcurrent protection. By accepting the same minimum trip on ground faults, this unit can also be connected to provide phase plus ground overcurrent protection. This is accomplished by utilizing a two phase and one ground overcurrent relay scheme. If a different value of ground minimum trip is required, the static ground fault unit must also be purchased.

Curve shapes can be changed by substitution of the phase boards. Each of three phase boards provides two time-delay curves and three instantaneous curves. See Application Data 38-733A, and Table 1 on page 10.

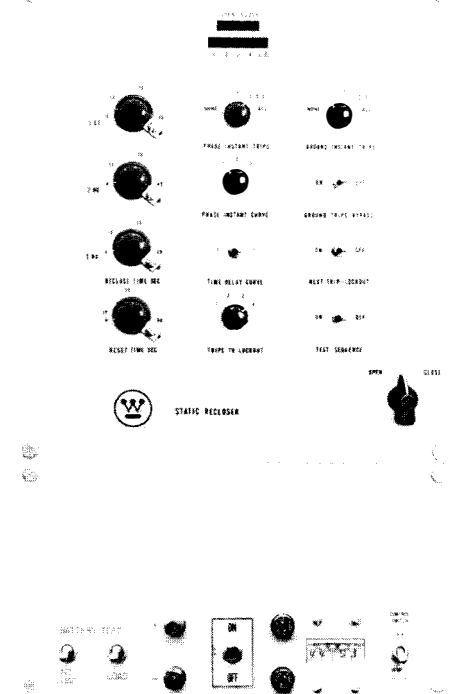

1. Phase Time-Delay Curves

Either of the two time-delay curves may be selected by setting a two-position toggle switch on the control panel.

2. Phase Instantaneous Curve

Any one of the three instantaneous phase curves per board may be selected with the three-position rotary switch on the control panel.

3. Phase Instantaneous Trip Selector

The static control can operate on either the instantaneous or the time-delay curve. A rotary switch on the front panel is provided to select which of the tripping operations are to be controlled by the instantaneous curve.

4. Phase Minimum Trip

Selection of the phase minimum trip current is made from the following table.

A minimum trip resistor establishes the trip current for each phase. A total of three resistors are required and they are mounted on a panel in the rear of the cabinet. They can easily be removed by disconnecting two mounting screws.

Phase Minimum Trip Current	Resistor Style [ⓐ] Number
50	2586C02H13
70	2586C02H14
100	2586C02H15
140	2586C02H16
200	2586C02H17
280	2586C02H18
400	2586C02H19
560	2586C02H21
800	2586C02H22
1120	2586C02H23
1600	2586C02H24

[ⓐ] Three Resistors Required

5. Operations to Lockout

The number of operations to lockout can be set by turning the selector switch to the appropriate position from one to four.

6. Reset Time

Any reset time from six (6) to sixty (60) seconds is possible. The reset timer is not started until after the recloser closes in on the line. The use of fast reset times is made possible by a fault monitor circuit which prevents the reset timer from operating if the current flowing in the primary is above the minimum trip setting.

7. Reclose Time

A separate rotary switch is available for each reclosing operation allowing any combination of reclosing times. The following reclosing times are available:

- 1st Instantaneous to 60 seconds
- 2nd 6 to 60 seconds
- 3rd 6 to 60 seconds

8. Indicating Lights

A top set of lights indicates whether the recloser is open or closed. The lower array of indicator lights shows the sequence state of the static counter, including lockout.

9. Control and Cold Load Pickup Switch

The control switch permits the operator to electrically trip or close the recloser. Holding this switch in the closed position raises the minimum trip setting of the control 2½ times without changing the shape of the curve or the coordination. This allows the recloser to remain closed for the duration of inrush current. Inrush current occurs when load is restored after an extended outage and rapidly subsides to normal (full) load levels. Normal minimum trip settings return when the switch is released from the close position.

For those applications where 2½ times normal minimum trip is not desired, this value can be set to any value between 1.0 and 2.5 times by specifying the desired multiple.

10. Next Trip Lockout Switch

This switch sets the control to operate on the instantaneous curve, cancels the reclosing function of the control, and sets the recloser to lock out after one instantaneous operation.

11. Test Sequence Switch

This switch is used to check the operation of the control and recloser. If the control and recloser are operating properly this will cause the recloser to trip and close in its programmed operating sequence.

12. Battery Test Device

This feature provides the user with a convenient method to periodically check the condition of the 24 volt DC Ni-CAD battery. A panel mounted test jack, 10 ohm load resistor, and two test switches are included to permit load and no load testing.

13. Power Switch

Allows the battery to be disconnected from the control during service by moving the toggle switch to the "off" position.

14. Control Power Fuse

A fuse provides protection for the low voltage circuit.

15. Electric Operations Counter

A counter with a cyclometer dial records each recloser operation.

Static Ground Fault

Ground fault protection with a minimum trip value different than the phase minimum trip setting is available as an optional catalog control.

1. Ground Instantaneous Trip Selector

The ground unit of the type MTR static control will operate on either the instantaneous or the time-delay curve. To select the tripping operations that will be controlled by the instantaneous curve, rotate the selector switch to the appropriate position.

2. Ground Minimum Trip Amperes

Selection of the ground minimum trip is made from the following table. A minimum trip resistor establishes the trip current for each phase. One resistor is required and it is mounted on a panel in the rear of the cabinet. The resistor can easily be removed by disconnecting two mounting screws.

3. Ground Trip Bypass

This switch, when in the "on" position, blocks the ground tripping function, thus eliminating the ground trip operation.

Ground Minimum Trip Current	Resistor Style Number [ⓐ]
5.8 [ⓑ]	
10.0 [ⓑ]	
25.0	2586C02H01
50.0	2586C02H02
70.0	2586C02H03
100.0	2586C02H04
140.0	2586C02H05
200.0	2586C02H06
280.0	2586C02H07
400.0	2586C02H08
560.0	2586C02H09
800.0	2586C02H10

[ⓐ] Accessory required. See catalog number LGMTG01 page 9 and item 13.1, P.L. 38-720, page 4.

[ⓑ] One resistor required.

Faulted Phase Indicator Unit

This unit provides visual indication of which phase has been subjected to fault conditions by indicating which phase or phases last tripped the recloser. A subsequent reclose on a different phase resets the previous phase target or targets. The faulted phase indicators may also be reset manually by pushing the reset button. Counters are available as an option to indicate the number of times each phase has caused the recloser to operate.

Ground Fault Indicator Unit

A target indicates when a ground fault has tripped the recloser. The target can only be reset manually by pushing the reset button.

A counter is available as an option to indicate the number of times ground faults have caused the recloser to trip.

Remote Trip and Close

The remote trip and close unit enables the user to trip and close the recloser from a remote location. This unit blocks the reclose function when the recloser is tripped from the remote location. Note: This feature requires 230VAC power. If other voltage, see Accessory 10, page 4, PL 38-720.

Accessories (Optional)

- **Three Mini-Ammeters:** Type GA 0-5 Amp Indicating Ammeters can be provided to indicate the phase current value. This accessory requires the use of a separate set of bushing current transformers that are selected from Selection Step 3, page 2 and a size 2, G03 or G04 cabinet.

Cat. No. 3MAG01

- **Thermal Demand Ammeter:** Sangamo ADH-2 Triplex Thermal Demand Ammeters will be provided with or without an instantaneous attachment. This accessory requires the use of a separate set of bushing current transformers that are selected from Selection Step 3, page 2 and a size 2, G03 or G04 cabinet.

S#402A869H04 w/o Inst.
S#402A869H09 with Inst.



• Zone Sequence Control Unit

For applications with two static controlled reclosers in series, it is recommended that the recloser nearest the source (upline) be equipped with the zone sequence accessory to maintain the desired coordination sequence of the two reclosers.

To ensure coordination between the instantaneous curves of the two reclosers, the instantaneous curve of the upline recloser must be slower than the downline recloser. To permit coordination with various types of reclosers, the zone sequence control unit of the MTR control allows the instantaneous trip time to be increased by 3-12 cycles.

If the fault is cleared by the down line recloser, the zone sequence unit of the source recloser only steps the static counter thus keeping the pre-programmed cycle in the proper sequence.

This accessory is provided on a plug-in board that mounts directly in front of the phase time curve board when viewed from the rear of the front panel.

Cat. No. ZSCG02

• Low Ground Minimum Trip

In order to provide ground minimum trip values below 25 amps, this accessory is required in addition to the ground minimum trip resistor selected on page 8. This accessory includes one extra set of bushing current transformers.

Cat. No. LGMTG01

• Phase and Ground Fault Counters

These counters are mounted on the front panel and count the number of times the recloser has operated.

Cat. No. PCTRG01, phase only.

Cat. No. GCTRG01, ground counter only.

Cat. No. PGCTRG01, phase and ground.

• Cold Load Pickup Resistor

This resistor raises the minimum pick-up by the value shown when the control switch is held in the close position.

Minimum Trip Multiplier	Resistor Catalog Number
1.5	CLP15G01
2.0	CLP20G01
2.5 Standard	CLP25G01

• Instantaneous Trip

This accessory trips the recloser instantaneously at any fault current above a preset level of fault current on the phase time current curve only.

Cat. No. ITG ___ ①

① Catalog number must contain 5 digits. The last 2 are variable from 01 to 99 which specify the multiple of minimum pickup that will instantaneously trip or lockout the recloser. Only the instantaneous trip or the instantaneous lockout may be specified since they cannot be combined.

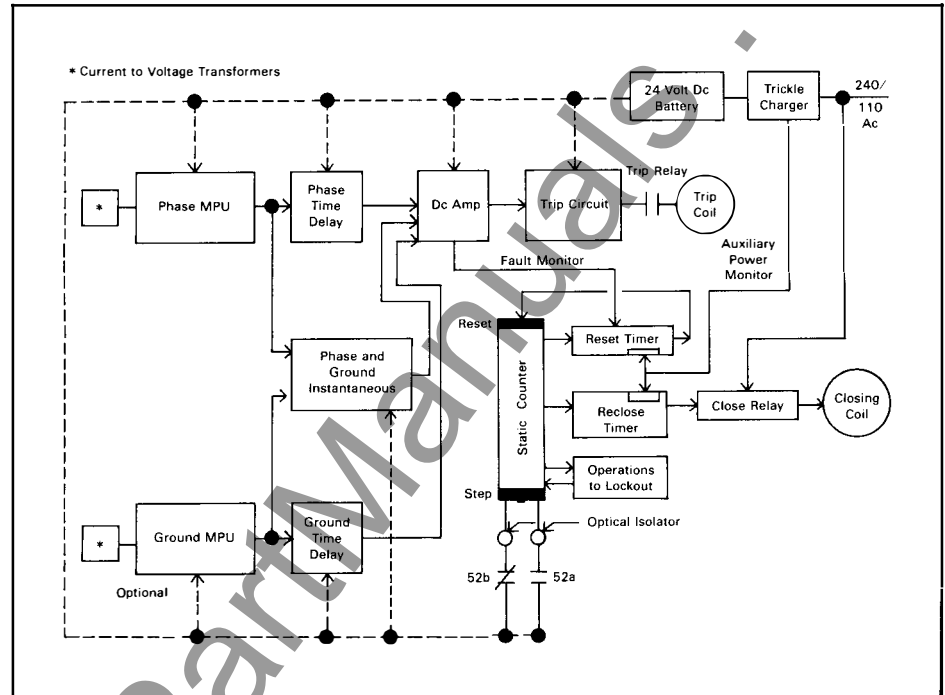

• Instantaneous Lockout

This accessory trips and locks out the recloser instantaneously on the phase time current curve at any fault current above a preset value.

Cat. No. ILG ___ ①

Description of Static Control Operation

Complete Adjustability and Flexibility Built In

The MTR Static Control has all of the necessary components required to give all of the timing values for reset and reclose operations outlined in this Application Data. In addition, the control has three-phase instantaneous curves and two-phase time delay curves built in. It is possible, therefore, to change these functions in the field without requiring additional parts.

Sequence of Operation (See Block Diagram)

Three 1000/5 bushing current transformers provide current sensing for the type MTR static control. The primaries of three current to voltage transformers for phase tripping are connected to the bushing current transformers. The secondary voltages are fed through full wave bridges connected in parallel. This paralleled connection of the bridges results in a "maximum voltage network," which feeds the minimum pick-up circuit. The voltage supplied to the phase curve shaping networks is proportional to the magnitude of the fault current on any phase.

After a time delay, determined by the fault magnitude, the curve shaping network sends a signal to the dc amplifier which in turn energizes the trip coil through the contacts of the trip relay.

The logic of the MTR static control is controlled by the static counter. The static counter is the static equivalent of a mechanical stepping relay that is set to allow the recloser to interrupt and automatically reclose a predetermined number of times. The position of the static counter in its cycle determines whether the tripping sequence will be instantaneous or time delayed and also determines the length of the reclosing time.

The reclosing timer circuit energizes the close coil through the contacts of the closing relay. The reclosing time delay circuit is a quick reset type allowing the same circuit to be used for all reclosing intervals. The reset timer is energized by a "B" contact of the auxiliary switch when the recloser closes and the current level is less than minimum trip.

When current flow is in excess of the minimum pick-up setting, a signal from the dc amplifier disables the reset timer preventing it from resetting the counter. This fault-monitor circuit makes possible reset times less than the maximum time delay trip without fear that the recloser may not lock out in the event of a low-current fault.

When optional ground tripping is supplied, an additional current to voltage transformer is connected to the bushing current transformer neutral to detect circuit unbalance.

The secondary voltage of this transformer is also applied to a full wave bridge. The output voltage is applied to the DC amplifier through the ground trip minimum pickup and curve shaping network.

Time Current Curves of the ESV Recloser with Static Control

Each static controlled recloser has included as standard equipment three instantaneous curves and two time delay curves for phase tripping. Units with the optional ground trip unit also include one instantaneous and one time delay curve for ground tripping. The curves must be selected from the following table.

The curves remain consistent as set within an accuracy of plus or minus 5% throughout the temperature range of -30 degrees C to +70 degrees C (-22 degrees F to +158 degrees F).

Table 1. Available Time Curves. ①

Description	Style Number
Phase Time Curve	
CO-8 (Standard)	201C963G01
CO-9	202C040G01
CO-11	202C298G01
Ground Time Curve	
CO-8	203C221G01
CO-9 (Standard)	203C221G02
CO-11	203C223G01
CO-9	671B592G01

① If other curves are required contact Westinghouse.

Ordering Information

The five major components of the type MTR static control listed on page 7 (excluding the accessories) have been combined into eight control packages. In addition, there are provisions for mounting and wiring the six optional accessory packages.

When ordering a static phase protection unit, the style number of the time curve must be selected and specified from Table 1. A time curve from the same Table 1 must also be selected and specified when ordering a static ground fault unit.

When ordering any of the six accessories described on pages 8 and 9, the appropriate catalog number or numbers and/or style number must be selected and specified.

Each of the package components contain all of the features described on pages 7 and 8 under each component.

Package Components

Package Control Catalog Number	Schematic Diagram 230 VAC Trip ①	Wiring Diagram 230 VAC Trip ①	Static Phase Protection Unit	Static Ground Fault Unit	Faulted Phase Indicator Unit	Ground Fault Indicator Unit	Remote Trip and Close Unit
SC301	5966C41	5966C42	•				
SC302	5966C43	5966C44	•				•
SC303	5966C45	5966C46	•				
SC304	5966C47	5966C48	•				•
SC305	5966C49	5966C50	•	•			
SC306	5966C51	5966C52	•	•			•
SC307	5966C53	5966C54	•	•	•	•	•
SC308	5966C55	5966C56	•	•			
Package Control Catalog Number	Schematic Diagram 24 VDC Trip ①	Wiring Diagram 24 VDC Trip ①	Static Phase Protection Unit	Static Ground Fault Unit	Faulted Phase Indicator Unit	Ground Fault Indicator Unit	Remote Trip and Close Unit
SC309	5966C57	5966C58	•				
SC310	5966C59	5966C60	•				•
SC311	5966C61	5966C62	•		•		
SC312	5966C65	5966C66	•	•			
SC314	5966C67	5966C68	•	•			•
SC315	5966C69	5966C70	•	•	•	•	•
SC316	5966C71	5966C72	•	•		•	

① Any other trip source from Selection Step 4 is possible, if specified by proper selection of the trip coil.

Selection Step 16 – Potential Transformers CBT

The CBT transformer is designed for use where the user has one system voltage and one secondary voltage is desired. A Bendix plug on the secondary of the two bushing units eliminates any exposed live parts in the control circuit. The CBT can be supplied with or without fuses in the H.V. bushings. See page 12 for mounting arrangement.

Table 1 CBT Transformer Catalog Numbers

High Voltage	BIL	Outline Drawing	No. of Bushings	Catalog Numbers 15 Kv H.V. Bushings		
				Without Fuses	With 1 Fuse	With 2 Fuses
2400 volts	95	PT06	2	PT06PX01	PT06PX01F	PT06PX01FF
4160 volts	95	PT06	2	PT06PX02	PT06PX02F	PT06PX02FF
4800 volts	95	PT06	2	PT06PX03	PT06PX03F	PT06PX03FF
7200 volts	95	PT06	2	PT06PX04	PT06PX04F	PT06PX04FF
7600 volts	95	PT06	2	PT06PX05	PT06PX05F	PT06PX05FF
7960 volts	95	PT06	2	PT06PX06	PT06PX06F	PT06PX06FF
8300 volts	95	PT06	2	PT06PX07	PT06PX07F	PT06PX07FF
12000 volts	95	PT06	2	PT06PX08	PT06PX08F	PT06PX08FF
12470 volts	95	PT06	2	PT06PX09	PT06PX09F	PT06PX09FF
13200 volts	125	PT08	2	PT08PX01	PT08PX01F	PT08PX01FF
13800 volts	125	PT08	2	PT08PX02	PT08PX02F	PT08PX02FF
14400 volts	125	PT08	2	PT08PX03	PT08PX03F	PT08PX03FF
16340 volts	125	PT08	2	PT08PX04	PT08PX04F	PT08PX04FF
19900 volts	125	PT08	2	PT08PX05	PT08PX05F	PT08PX05FF

CBT Transformer Rating

As mentioned under ordering information, the catalog and quantity of CBT transformers must be specified. All CBT transformers are available with or without fuses as shown in Table 1. Secondary voltage in all cases is 240 VAC.



Ordering Information

Catalog numbers have been assigned to the connection equipment for CBT transformers. Included in the catalog number is all the necessary connectors, cable, gasket, bracket, bolts, nuts, and lock washers to mount one CBT transformer. This transformer is mounted on the left as you look into the mechanism compartment. If a second CBT transformer is required, a quantity of two must be specified and the second unit will be mounted on the right side as you look into the mechanism compartment.

Connection Equipment

Catalog No.	Description
PETLLG01 ①	CBT Transformer Connection Equipment 95 or 125 BIL 2 bushing units Line to Line - 1 unit substation frame
PETLGG01 ①	CBT Transformer Connection Equipment 95 or 125 Kv BIL 2 bushing units. Line to ground - 1 unit subframe
PETPLLG01 ●	Same as PETLGG01 except for pole mounting 95 or 125 Kv BIL 2 bushing units
PETPLGG01 ①	Same as PETLGG01 except for pole mounting frame 95 or 125 Kv BIL 2 bushing units

① Catalog number of CBT Transformer must also be specified. See Table 1 this selection step for units available. If two transformers required, then quantity of two must be specified for both connection equipment and CBT transformer.

Other Optional Accessories

Ground Wire Monitoring Scheme

Westinghouse has available a circuit that monitors the customer's ground circuit. The scheme trips and locks out the recloser after one operation should the customer's ground circuit open. Closing the recloser resets the circuit. The scheme can be modified to include one shot to lockout for overcurrent relay tripping.

Bill of Material includes:

- Signal Transformer
- Auxiliary Current Transformer
- Ballast Resistor
- SC Relay
- GA-332 Ammeter (0-5A)
- Latching Relay
- 2-3000 ohm Resistors (if other than 24 VDC Trip)
- Special Capacitor Trip Device

The scheme will operate off any control power source; however, the preferred tripping source is a capacitor trip device. Select the proper control package from Step 11. The scheme is not applicable to static controlled reclosers.

See P.L. 38-720 for other optional accessories and description.

Dimensions In Inches - CBT Transformer 110 Kv BIL

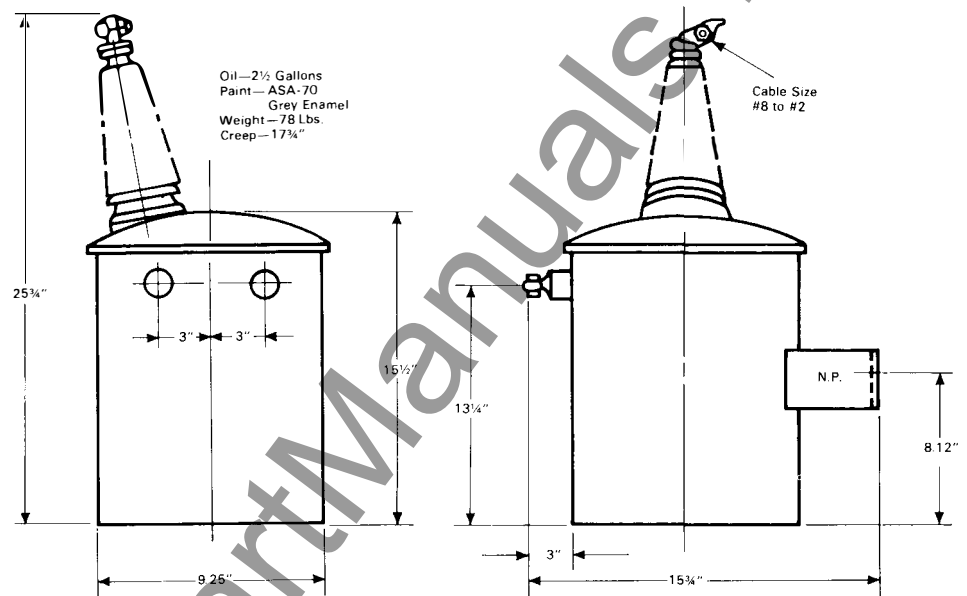

BIL	Dimensions in Inches			Wgt., Lbs.
	A	B	Creep	
95	23.25	6.25	11.00	84
125	25.75	8.75	17.75	86

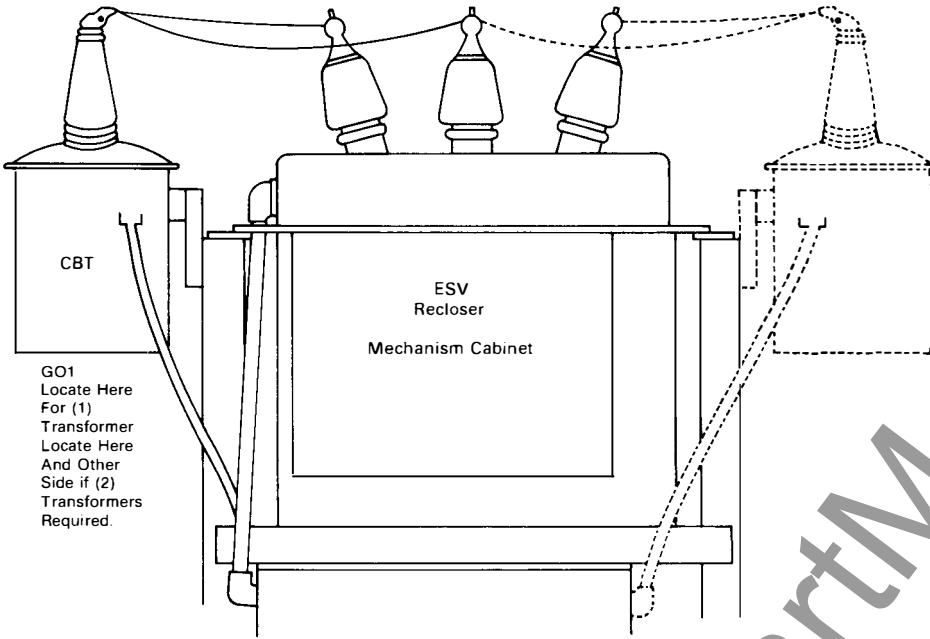

Further Information:
PL 38-720
DB 38-726
DS 38-728

Figure 1 CBT Transformer Connected Phase-to-Phase (95 or 125 Kv BIL) Mounted on Substation Frame

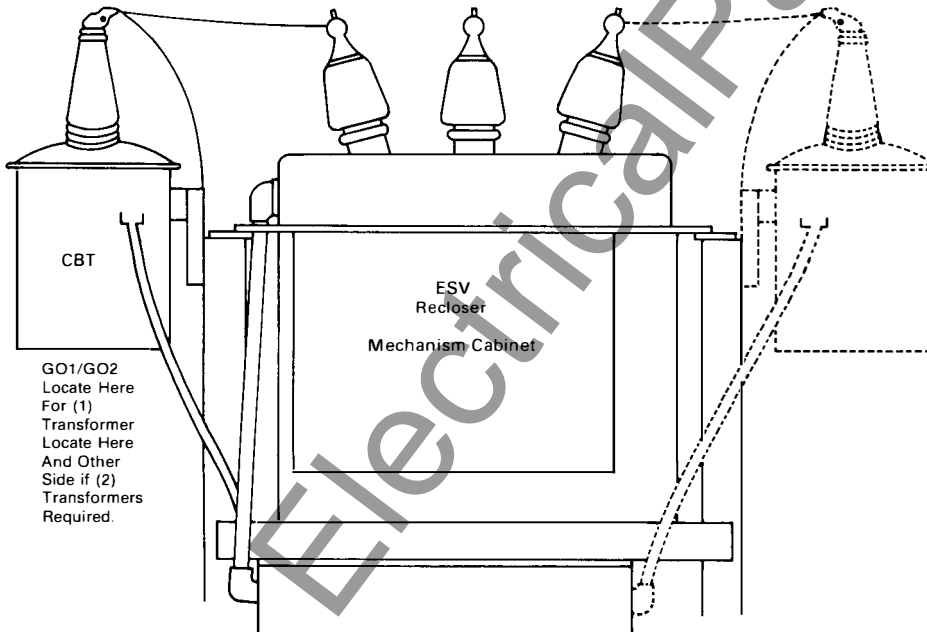

Figure 2 CBT Transformer Connected Line-to-Ground (95 or 125 Kv BIL) Mounted on Substation Frame