

Westinghouse

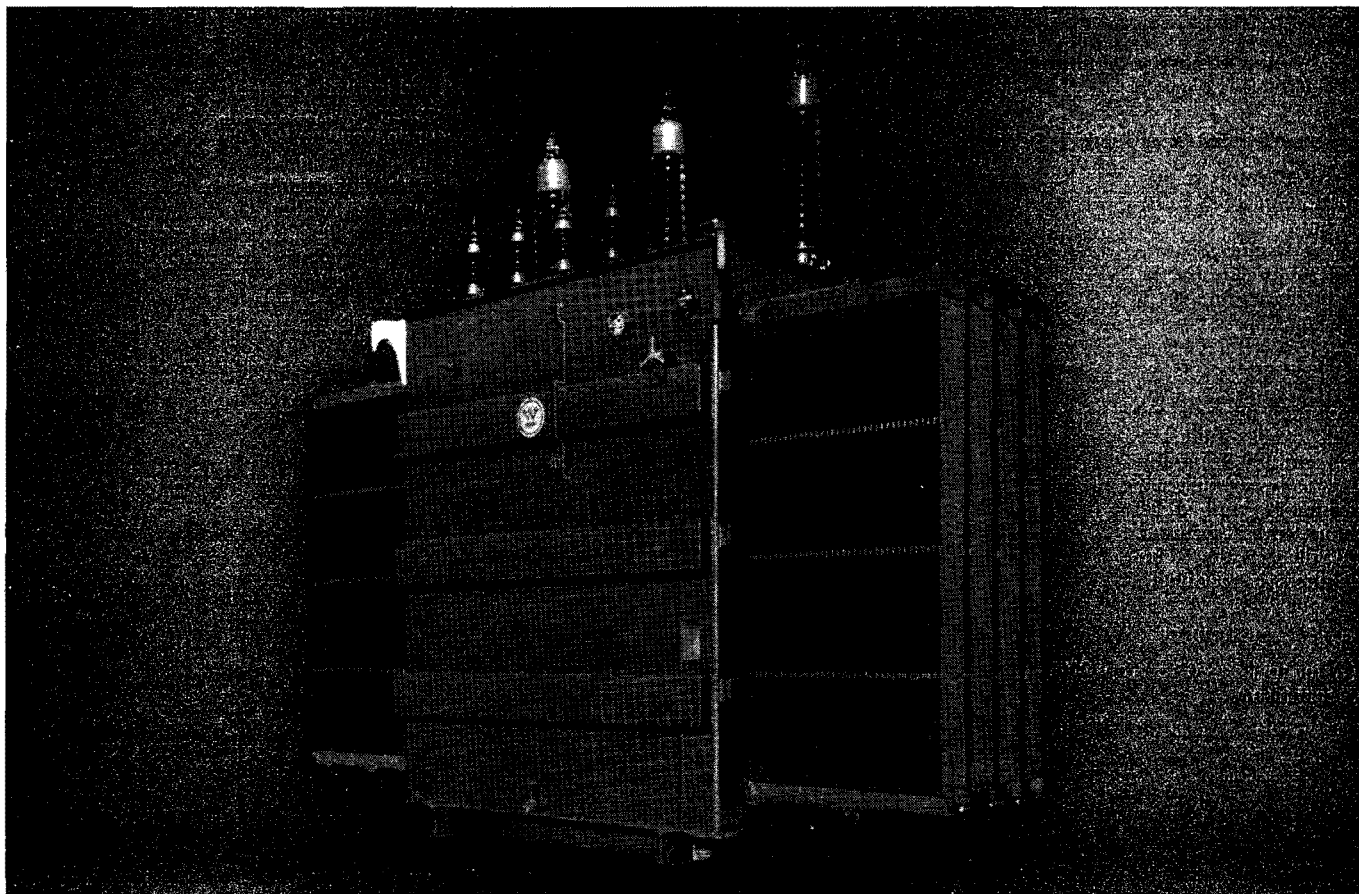

## Medium Power Transformers

OA, OW, OA/FA, OA/FA/FA,  
OA/FOA/FOA, FOA, FOW  
Three Phase: 10001 – 30000 Kva OA  
20000 – 50000 Kva FOA  
Single Phase: 10001 – 20000 Kva OA  
16667 – 33333 Kva FOA  
750 Kv BIL and Below



### Application

Medium Power Transformers are designed in accordance with USA Standard C57.12.00 to meet the need for reliable and economical power transformers used in large substations and in generating stations. They are designed to meet a wide variety of Electric Utility and Industrial loads.

### Advantages

#### Modern Design and Construction

Application of advanced engineering techniques and optimized design computer programs result in a balanced design. Efficiency and reliability are emphasized while size and weight are kept to practical values.

A continuing plant modernization program provides the latest in automated equipment and modern manufacturing processes to assure a high quality product.

#### High Short Circuit Strength

Research developed and thoroughly tested designs provide the short circuit strength

necessary to repeatedly withstand the increasingly large short circuit currents available in modern systems.

#### Highest Thermal Capacity

The improved Insuldur® insulation system and WEMCO C insulating oil result from an extensive program of research and development in the chemistry of insulating materials carried on by Westinghouse.

#### High Dielectric Strength

Advanced designs resulting in a low ratio of coil-ground capacitance, a proper balance of solid and liquid insulation and the ability to solve creepage problems provide the high dielectric strength needed to withstand impulse voltage requirements.

#### Easier Handling and Reduced Maintenance

Compact designs reduce cost of rigging and hauling and require smaller installation space. Clean design and simplified accessories reduce maintenance costs.

### Complete Line

Medium Power Transformers are available in all classes of cooling as autotransformers, transformers with more than two windings, with zig-zag windings and other variations to meet specific customer requirements or special system conditions. They are also available with or without load tap changing equipment.

### Ratings

**Kva:** 10001 through 30000 OA, 3 phase  
20000 through 50000 FOA, 3 phase  
10001 through 20000 OA, 1 phase  
16667 through 33333 FOA, 1 phase

**Frequency:** 25, 50 or 60 cycles/sec.

**Voltage:** Through 750 kv BIL

**Temperature Rise:** 55/65°C or 65°C

**Accessories:** Refer to PL 48-420 for complete listing.

# Westinghouse



## Design Features (Standard)

### Cover Mounted Bushings (Refer to Page 7)

### Magnetic Liquid Level Gauge

Float position transmitted magnetically through tank wall to gauge pointer preserving tank seal. Supplied with alarm contacts, if specified.



### Dial Type Thermometer

Mounted in well on tank wall. Indicates temperature of top liquid. Has magnetically resettable red peak temperature pointer. Supplied with alarm contacts, if specified.



### Tap Changer

(Refer to Page 6 for Tap Changer Internal Mechanism)

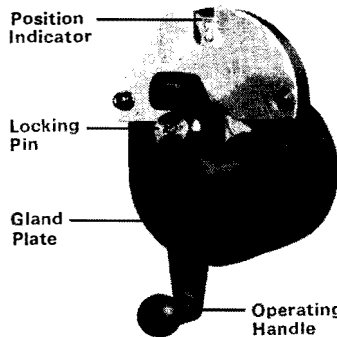

External operator for tap changers 350 kv BIL and below.

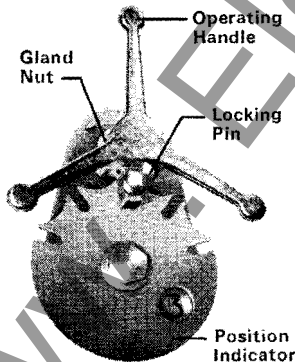

External operator for tap changers 450 kv BIL and above.

Operating handle is brought out through side of tank at a height convenient to the transformer design and includes provision for padlocking.

### Upper Valve for Filter Press Connection

### Lower Drain Valve, Filter Press Connection and Sampling Valve

Assures bottom sampling and complete oil drainage from tank sump.

### Tank Grounding Provision

Two copper faced steel pads with standard holes for bolting on connection located on back and front tank walls near base.

### Base

**Flat Plate Type (Not Shown)**  
Flat plate base, with beveled edges, in complete contact with foundation pad, excludes air and moisture when properly grouted in. No cavity to form a sound resonant chamber.

**I-Beam Type (Optional)**  
An optional base arrangement may be specified if total (or shipping) height is not critical, consisting of welded structural I-beam sections. The members are arranged and shaped for ease in skidding or rolling the transformer. Holes are provided for pulling, tie-down and ventilation.

### Provisions for Jacking

### Instruction Nameplate

Stainless steel nameplate mounted on tank wall at convenient height.

### Sealedaire Oil Preservation System

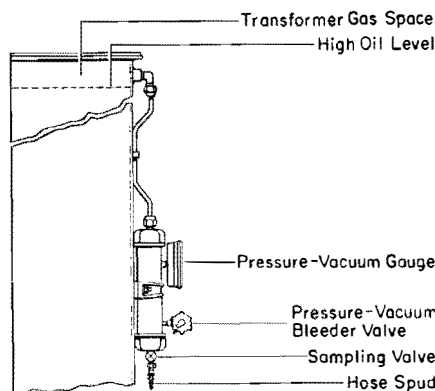

Westinghouse Sealedaire system of oil preservation excludes oxygen and moisture, thus preventing deterioration of the liquid and insulation. The transformer tank (when specified by standards) is filled with oil under vacuum. A relief valve assembly keeps the transformer sealed throughout an oil temperature range of 100 degrees C. Pressure and vacuum limiting valves are set to open at plus or minus 6.5 pounds per square inch. Gas samples for purging or for analysis may be taken.

### Pressure Vacuum Gauge

Indicates pressure inside tank gas space.



### Lifting Lugs and Eyes

Total of four lifting lugs on corners of tank for lifting entire unit.

### Main Tank Cover

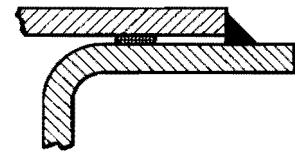

Welded on, provided with lifting eyes and manholes for access to inside of tank.

### Mechanical Relief Device

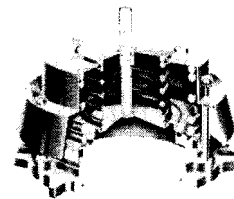

Relieves abnormally high internal pressure. Factory calibrated to operate at 10 psi. Easily visible operation pointer. After operation, positively reseals and continues to give protection against the elements.

## Medium Power Transformers

OA, OW, OA/FA, OA/FA/FA,  
 OA/FOA/FOA, FOA, FOW  
 Three Phase: 10001 – 30000 Kva OA  
 20000 – 50000 Kva FOA  
 Single Phase: 10001 – 20000 Kva OA  
 16667 – 33333 Kva FOA  
 750 Kv BIL and Below

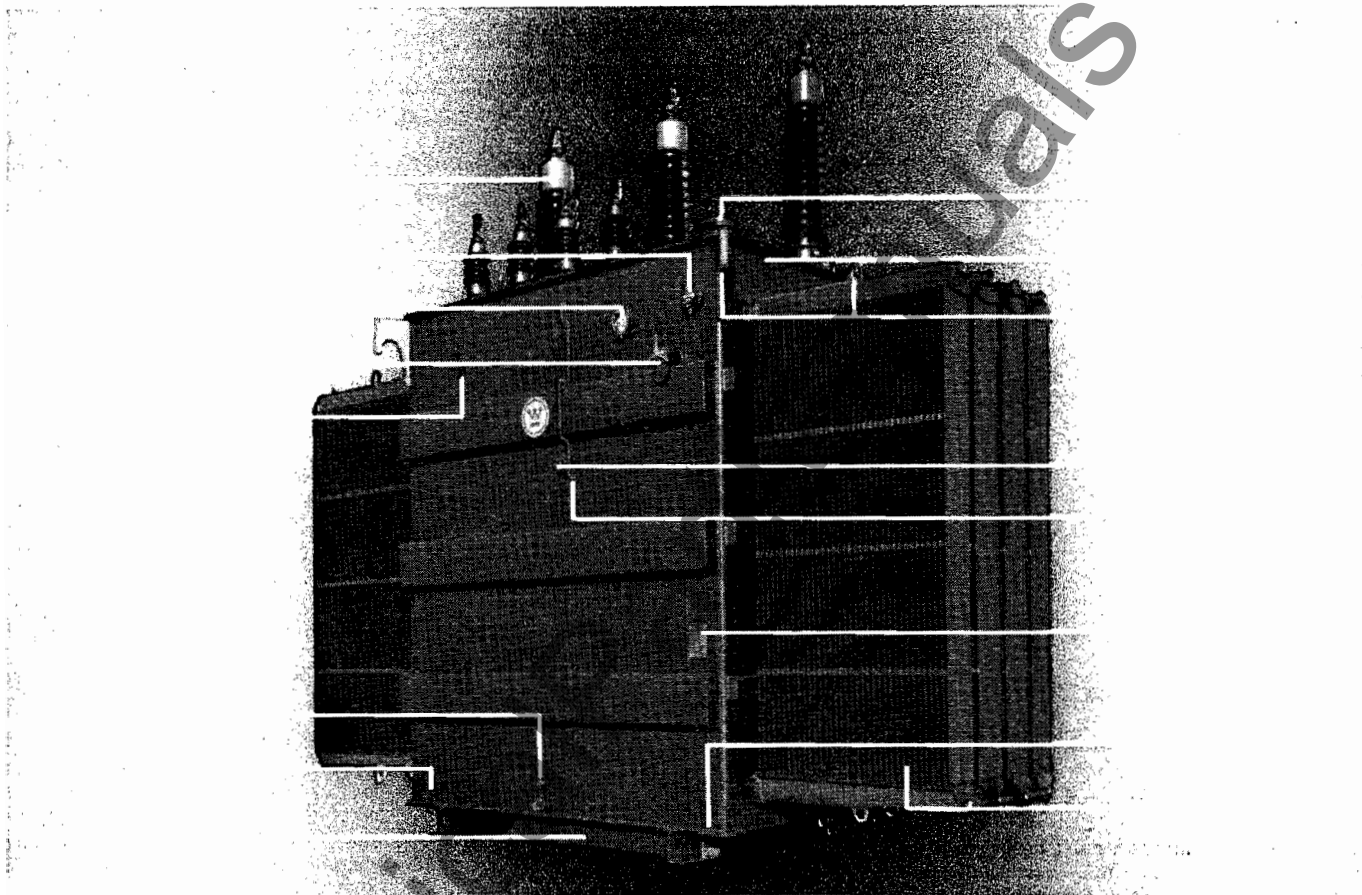

### Cooling

The type and number of cooling units on transformers with a self-cooled (OA) rating will depend on the shipping clearance, rating of unit, and other physical factors and will be optimized at the time the transformer is designed.

### Welded on Radiators

Where shipping clearances permit, tubular radiator headers will be welded directly to transformer tank.

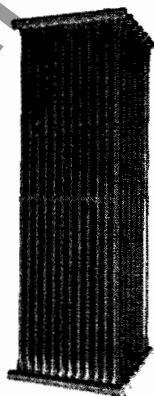
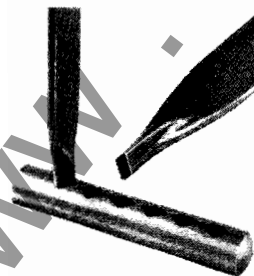

### Removable Coolers

On larger transformers, fin type removable coolers are provided.

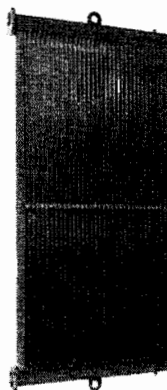
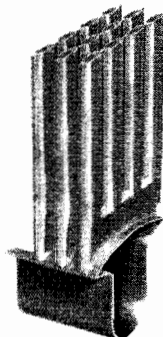

Shut-off valves are supplied on each cooler at the top and the bottom openings.

### Forced Oil/Air

Oil to air heat exchanger designed for use with pumps and fans in continuous operation.

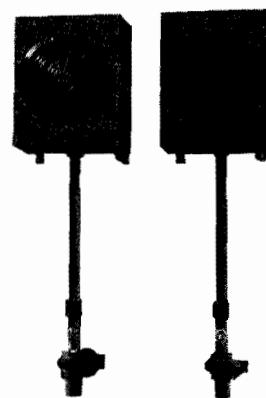

### Water Cooled

Oil to water heat exchanger for OW natural oil circulation or with oil pump for FOW operation.

Westinghouse



### Design Features, Continued Core and Coil Assembly

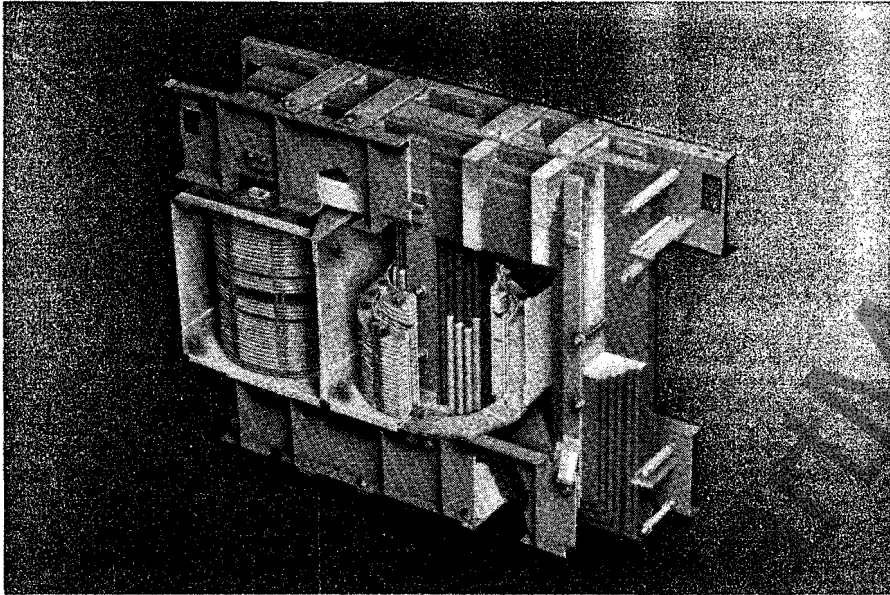

Core and coil assemblies are rigidly braced to withstand the mechanical forces under line fault conditions and to resist vibration and shock forces during shipment.

With the growth of power system size and complexity due to the EHV and other interconnections, transformers must now withstand more frequent and more severe short circuits. Westinghouse core form transformers have kept pace with these requirements by continual improvements in mechanical bracing of the core and coil assembly, processing of the coils and by more efficient use of better insulating materials.

The forces generated during short circuits are of a large magnitude in both horizontal and vertical directions. The horizontal forces are easily contained because the low voltage coil tends to compress against the core and high voltage coil is in tension and is inherently strong in this direction. The resultant vertical forces, however, are of such a nature that a 1 1/2% axial displacement of the electrical center-lines, caused by such factors as taps and manufacturing tolerances, may result in several hundred thousand pounds of force.

For every transformer the short circuit forces, to which the transformer may be subjected, are accurately calculated and the coils designed to withstand these resultant stresses using new insulating materials and special manufacturing techniques.

Every pancake type coil is verified for serv-

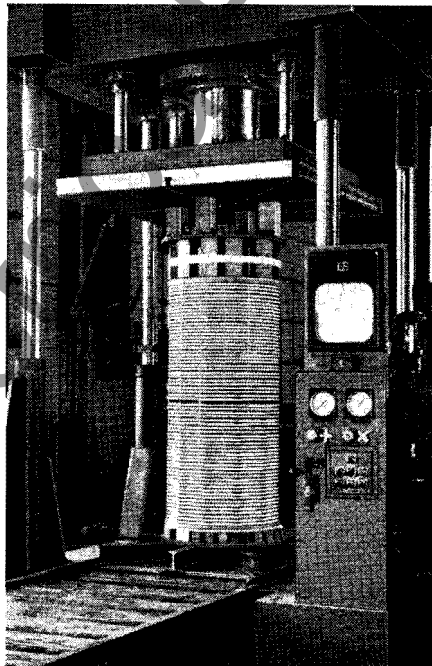

Figure 1: Circular Coil Pre-Stressing

ice by being pressed hydraulically (see Figure 1) to the calculated short circuit force. Thus, these coils which are almost half cellulose in the vertical dimension are actually "pre-stressed" at the factory with

the forces that they must withstand in service. This assures tight clamping and elimination of any slack which could permit coil movement and resultant failure.

#### Lateral Bracing

Coils are concentrically assembled on the core legs and rigidly braced laterally against the core.

High currents in the windings tends to force compression of the low voltage winding on the core while the high voltage winding takes the repulsive force in tension in the conductors. The selection of aluminum or copper for conductor material depends on the resistivity, mechanical strength and space factor requirements.

#### Vertical Bracing

Vertical movement is prevented by three carefully coordinated structural links. The forces originating in the coil are uniformly transmitted through the plate-type pressure ring and restrained by the end frames and steel lock plates, the latter being adjacent to the coil and extending its full height.

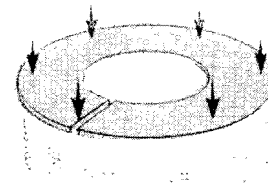

Depending on design considerations involving voltage class, impedance, etc., the pressure ring may be of one of three types of material. Rings cut from carbon steel plate are supplied where the coil end electromagnetic field is less severe.

Filament wound epoxy glass rings thermally processed for high strength and durability may be supplied in those designs where the field would be distorted by, or cause local heating in, a normally placed solid plate ring. Made of non-conducting material the ring does not require extra thicknesses of insulation effecting a height savings.

The rings may be wound of corrugated strips of high permeability Carlite coated electrical sheet steel. This construction is used on the largest ratings where forces are very high and coil end fields are large. These rings are wound with the wide part of the laminations parallel to the leakage flux lines to reduce stray losses in the rings and end turns of the coils.

The use of the wound epoxy glass or electrical steel rings make possible more compact transformers with no sacrifice of short circuit strength or efficiency.

## Medium Power Transformers

OA, OW, OA/FA, OA/FA/FA, OA/FOA/FOA, FOA, FOW  
 Three Phase: 10001 – 30000 Kva OA  
 20000 – 50000 Kva FOA  
 Single Phase: 10001 – 20000 Kva OA  
 16667 – 33333 Kva FOA  
 750 Kv BIL and Below

### Coil Construction

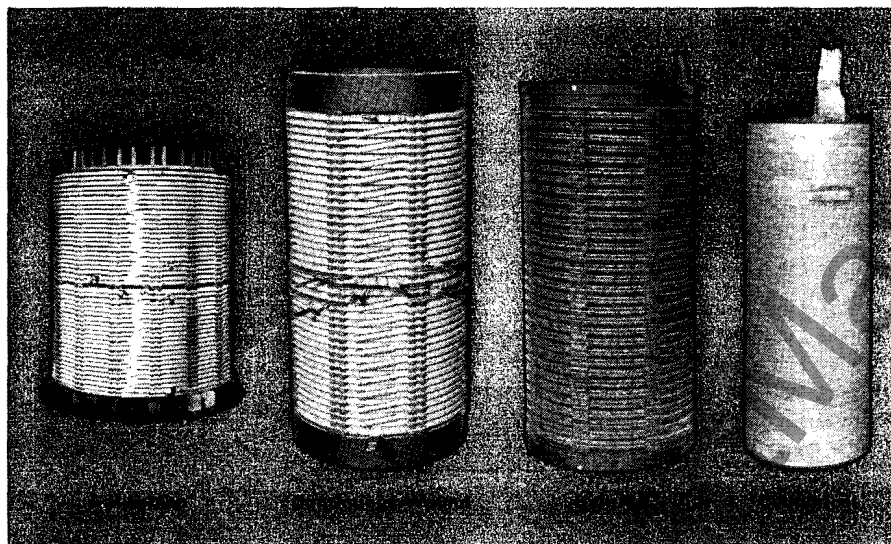

The usual types of high voltage windings used are Hisercap and continuous-wound and for the low voltage windings are cylindrical and Helitran.

#### Hisercap

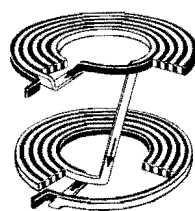

$C_1$  is Relatively High Due to Large Voltage Difference Between Adjacent Turns and are in Parallel Giving The Coil a High Through Capacitance,  $C_2$

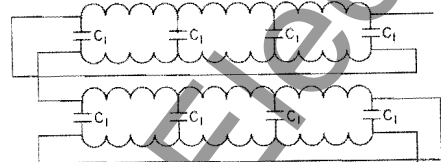

Hisercap windings (for voltages 450 kv BIL and above) are mechanically similar to the continuous wound except that the turns are inter-leaved to obtain a high series capacitance.

The figure above shows this inter-leaved winding which is wound with two (2) straps in parallel spaced and connected so that the series capacitance is higher.

This results in nearly a straight-line distribution of impulse voltages. Extra care is taken to provide large physical spacing between adjacent electrical turns.

#### Continuous Wound

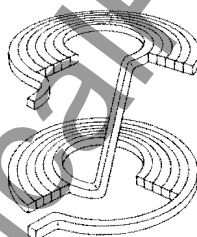

$C_1$ -Turn to Turn Capacitance Relatively High  
 $C_2$ -Section to Section Capacitance Relatively Low

Since  $C_1$  is in Series, this Reduces thru Capacitance  $C_2$  of the Winding which is Mainly that of the  $C_2$  Capacitance Therefore  $C_2$  is Low

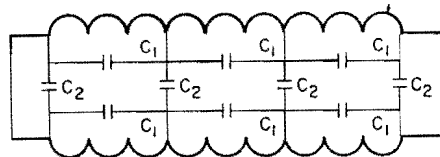

Coils from 110 kv BIL through 350 kv BIL are continuous-wound type as illustrated above.

The continuous-wound pancake consists of a column or stack of disc sections separated by horizontal oil ducts. The conductor consists of one or more rectangular straps in parallel, wound continuously over-vertical insulation strips on a pressboard cylinder. Vertical oil ducts separate the conductor from the cylinder.

Near ideal impulse voltage distribution resulting from high series capacitance is illustrated in the following figure.

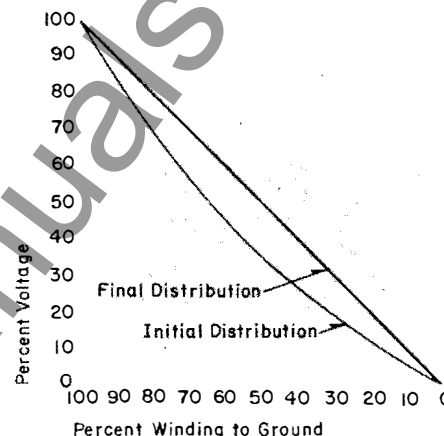

#### Helitran

Helitran windings (coils with only a few turns and currents of 600 amperes or more) are particularly adapted to withstand the high short circuit stresses encountered in high current windings.

#### Cylindrical Wound

The cylindrical-wound coil (voltages to 95 kv BIL and currents up to 2500 amperes) consists of one or more layers of insulated conductors on a heavy pressboard cylinder with oil impregnated pressboard insulation and vertical cooling ducts between adjacent layers.

The windings are wrapped with epoxy glass tape which, after the baking operation mentioned below, tightens and forms a band around the coil as strong as steel to positively prevent conductor movement during short circuit.

About 90% of the vertical dimension of cylindrical coils is non-compressible material; but to eliminate any possible turn-to-turn slack and to control height of coils accurately, Westinghouse uses a unique system of coil treatment. After these coils are wound, the assembly is securely clamped by means of spring loading and oven dried under spring pressure to insure a tight coil.

End collars are then accurately sawed to assure a match in height of the adjacent high voltage coil. This construction prevents turn-to-turn movement under short circuit stress.

#### Proven Design

To prove the design concepts and construction, production units of the largest kva ratings have been given multiple short circuit tests to full rated capacity in the Westinghouse high power laboratory in East Pittsburgh, Pennsylvania.

Westinghouse



**Design Features, Continued  
Insuldur® Insulation**

The Insuldur insulation system effectively upgrades cellulose insulation materials thermally for increased load and overload capability. Ask for SA 9025 for a complete description of the Insuldur system.

**Vapotherm Insulation  
Processing**

Coil assemblies are securely clamped by means of spring loading in the vertical dimension and thoroughly dried out by the Vapotherm process. This process is carried out in an atmosphere devoid of oxygen. The heat of vaporization of a hydrocarbon solvent is transferred directly to the insulation being treated. A rapid, uniform drying throughout the entire coil is accomplished without danger of destructive overheating of some areas. After dryout and while under a high vacuum, the coils are completely immersed in a penetrating dry oil before being exposed to external atmosphere. The completed unit is processed in its own tank with hot oil to remove any surface moisture picked up during assembly.

**Cores**

Hipersil cores of cold-rolled, highly permeable silicon steel laminations carry one-third more flux than ordinary electrical steel per unit area. The grain is oriented for optimum transmittal of flux.

Non-reacting interlaminar carlite insulation reduces core space nine percent, resulting in more compact cores. This requires less material in the winding which, in turn, results in lower losses, smaller size and lighter weight while still maintaining proved performance.

Cores of circular core form transformers are stacked on a new automated core stacker assuring uniform high quality of all core assemblies.

Cores of circular coil transformers are approximately circular in cross section (see A-A), and the angled core corners produce optimum magnetic qualities for efficient flux flow.

Flux crowding is minimized by small diameter bolts insulated by Micarta tubes and pressboard washers, which secure the core

laminations. These bolts can be small because the core itself is not a part of the coil bracing system. Core legs are not stressed by clamping.

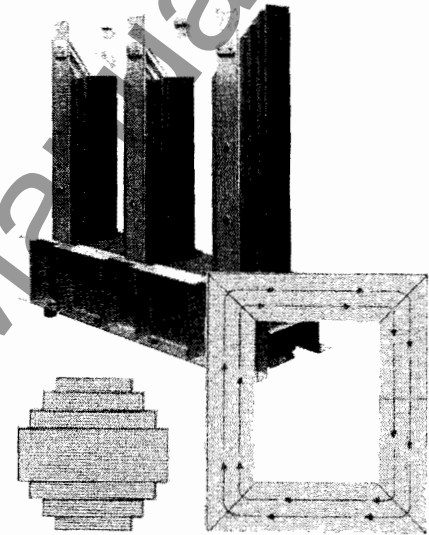

**De-Energized Tap Changers**

Two types of tap changers are used to change transformer taps when de-energized. The type WSB is used, 350 kv BIL and below and the type WHV above 350 kv BIL (see page 2 for external operating mechanisms).

Self-cleaning moving contacts are employed which are wiped clean on each tap changer operation. Two parallel moving contacts provide firm positive pressure, even during faults because of a magnetic effect during current flow.

The mechanical design employs a Geneva gear-cam assembly which controls the movement of the tap changer and assures positive positioning at the end of the complete revolution.

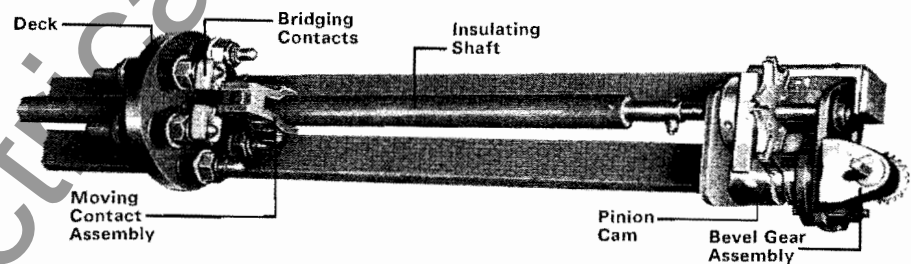

Single Deck WSB-4 Tap Changer

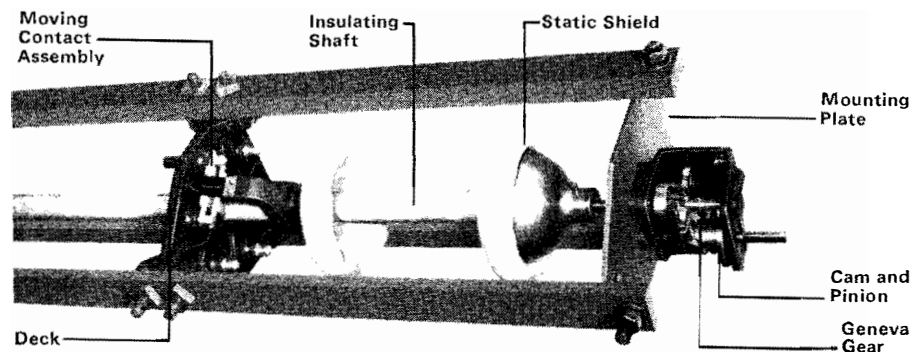

Single Deck WHV Tap Changer

## Medium Power Transformers

OA, OW, OA/FA, OA/FA/FA,  
OA/FOA/FOA, FOA, FOW  
Three Phase: 10001 – 30000 Kva OA  
20000 – 50000 Kva FOA  
Single Phase: 10001 – 20000 Kva OA  
16667 – 33333 Kva FOA  
750 Kv BIL and Below

### Westinghouse Insulating Oil WEMCO "C"

Concurrent with the Insuldur development, Westinghouse was working with the various petroleum companies to develop a higher flash-point oil for additional margin of safety. Westinghouse Research, developed and provided to all of the oil suppliers the required information needed to refine a new higher flash-point oil and made it available to all the industry. The flash-point was raised from 273°F to 283°F while equalling or bettering the remaining characteristics including lower pour point.

### Standard Finish

The Westinghouse standard finish is a three-coat system applied as follows:

A. All surfaces are grit blasted to white metal to form a completely clean, textured surface for ideal paint adhesion.

B. A rust inhibiting primer coat, composed of an alkyd type vehicle with zinc chromate and iron oxide pigments, is applied.

C. Two coats of Westinghouse top coat, composed of an alkyd type vehicle containing special pigments selected to give long outdoor service in varying climatic exposures and maintain attractive appearance, are applied.

Standard tank finish is USA standard dark grey No. 24 (Munsell No. 10B2.40/1.18), USA standard sky grey No. 70 (Munsell No. 5.0BG7.0/0.4) or light green (Munsell No. 9.0G4.5/1.8) can be supplied but must be specified at the time the order is placed.

### Bushings

Two types of bushings are furnished: RJ type for voltages 15 kv and below and the condenser type for higher voltages. Both types are cover mounted and comply with all industry standards pertaining to electrical and mechanical characteristics.

### RJ Bushings

RJ bushings feature a flange with silicone rubber seals rolled into grooves cut in the porcelain. So supported, bushings cannot crack due to uneven tightening in assembly or from stresses of normal operation.

### Condenser-Type Bushings

Used for voltages above 15 kv, type OS or type O meet all USA standards. In both, the condenser surrounds a central metal tube or bar. At specified diameters, metal foil layers are inserted to form the condensers. Thus, a series of equal capacity condensers is arranged between the central conductor and the outermost foil layer which is connected to a grounded flange. Voltage is, therefore, uniformly distributed to prevent concentration of stress at any one point.

Type OS bushings are used for voltages 23 through 46 kv. The resin bonded condenser is protected on its outer end by a porcelain weather casing and on its inner end by varnish and oil. The space between the porcelain and condenser is filled with oil. The top end of the porcelain is soldered to the cap, and the bottom of the porcelain is soldered to the mounting flange. No gaskets, packing or cement are used in the construction.

Type O bushings are used for voltages above 46 kv. The condenser is entirely enclosed in an oil-filled chamber. The oil completely penetrates the kraft paper between foil layers producing an oil-impregnated condenser. The entire chamber is sealed – joints between metal above the oil level are soldered, brazed or welded. Those between metal and porcelain are gasketed with cork-neoprene and retained by neoprene-asbestos stop gaskets. Oxidation of the oil is minimized by filling the gas space above the oil with nitrogen under low pressure.

The porcelains on all bushings will be furnished with standard brown porcelains.

USA No. 70 grey porcelains can be furnished instead of brown, if specified on the order.

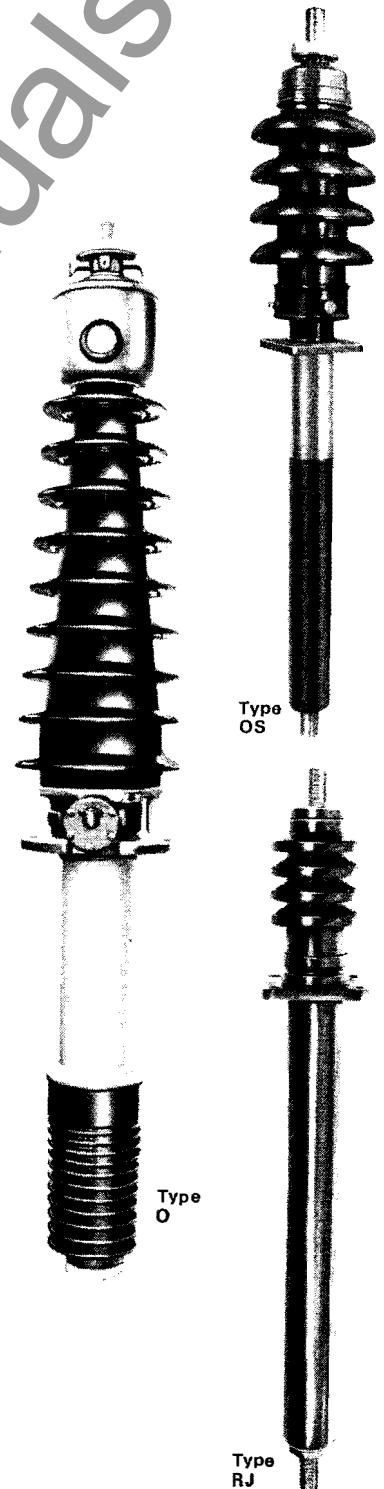

Westinghouse



### Transformer Cooling

Transformers may be cooled by several methods. In determining the best method for a given installation, the application engineer must take into consideration many factors such as cost of power, load cycle, noise problems, and future requirements. The classes of cooling are specified by USA Standard C57.12.00. The types of cooling equipment are shown on page 3.

#### OA Self Cooled

Generally applied in the lower kva range, where the cost of power dissipated as losses is highest, load cycle peaks are moderate and load fairly constant. Applied as OA only where future load growth is very modest or as OA with provisions for future fans where a growth in the loading is anticipated several years away. May be specified at 55°C rise continuous at rated load in a 30°C average 40°C maximum (for any 24-hour period) ambient temperature and due to the Insuldur insulation system will be good for 12% additional kva at 65°C rise continuous or may be specified as 65°C rise at rated load. Requires the least maintenance of any cooling system.

#### OA/FA Self-Cooled/Forced Air Cooled (also OA/FA/FA)

The circulation of oil through the coolers and coils is the same as for OA type of cooling. The rate of transfer of heat from the coolers to outside air is increased when fans are in operation by forcing air flow over the surface. Where welded-on tubular coolers are furnished, the fans will mount on top of cooler banks and blow downward with maximum air flow over areas of highest temperature gradient. Where removable finned radiators are furnished, fans will mount on the side of the radiator in such a manner as to force circulation through ducts formed by the rows of fins, greatly increasing the convection heat transfer.

Fan motors will be 1/6 hp suitable for operating from 230 volt single phase power supply furnished by customer. Three phase 230 volt motors will be furnished if specified on the order. The number of fans furnished will depend on the transformer rating and losses. Fan blades are designed for quiet operation. A winding temperature relay as shown on page 14 will be furnished for control of fans.

The increase in rating for units when fans are in operation and the FA rating of 55°C rise unit operating at 65°C rise are shown in PL 48-420.

OA: OA/FA

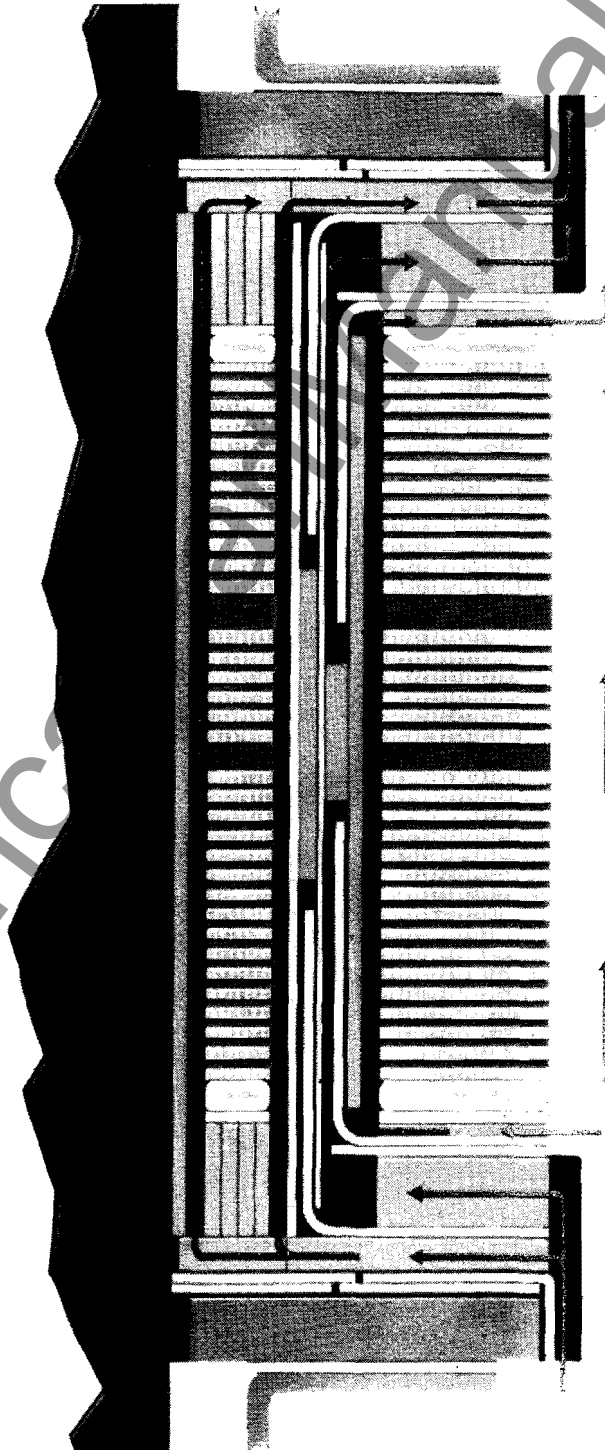

### Medium Power Transformers

OA, OW, OA/FA, OA/FA/FA, OA/FOA/FOA, FOA, FOW  
Three Phase: 10001 – 30000 Kva OA  
20000 – 50000 Kva FOA  
Single Phase: 10001 – 20000 Kva OA  
16667 – 33333 Kva FOA  
750 Kv BIL and Below

OA: Oil-Immersed, Self-Cooled

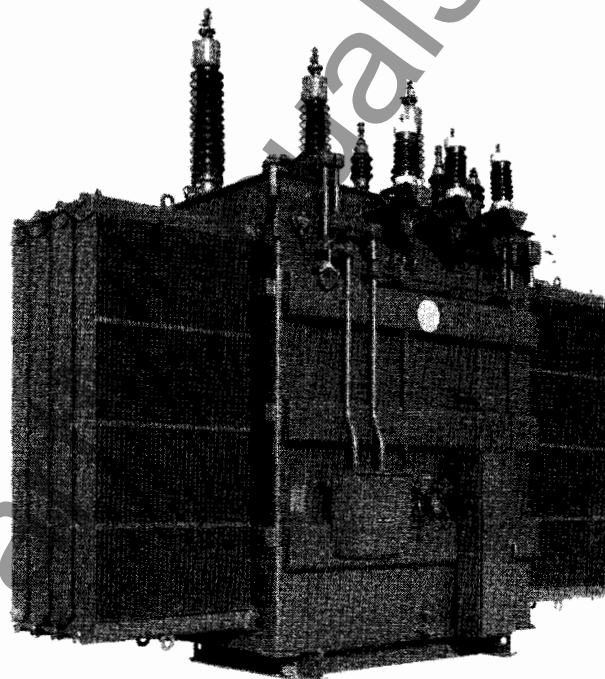
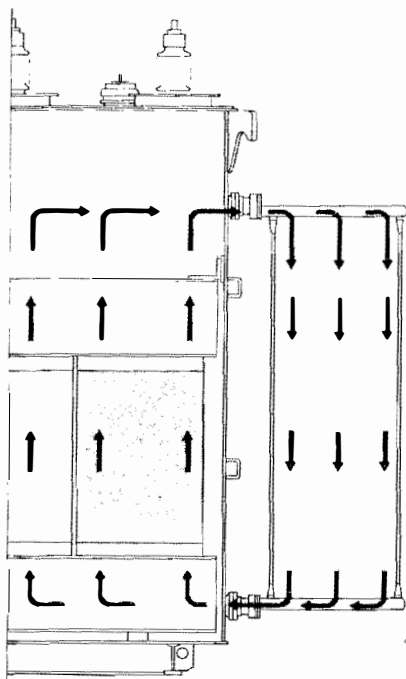

OA/FA: Oil-Immersed, Self-Cooled/Forced-Air Cooled (also OA/FA/FA)

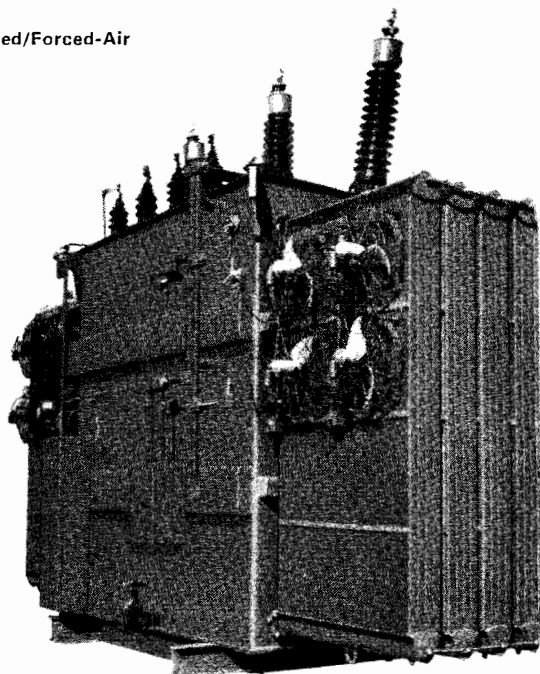
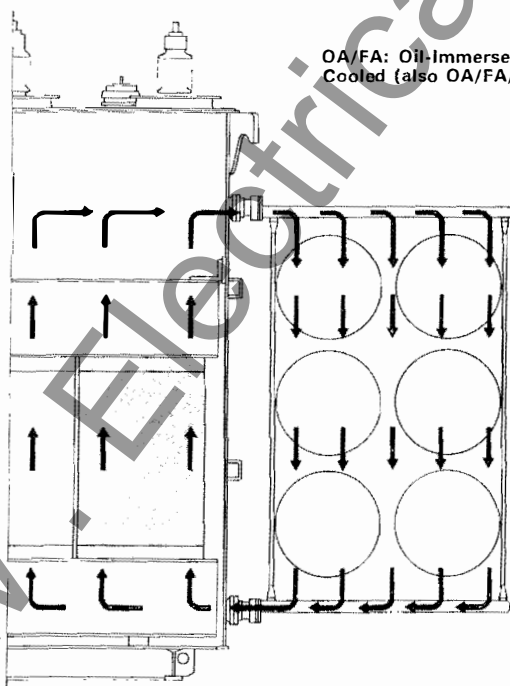

## Westinghouse

**OA/FOA/FOA Self-Cooled/Forced  
Air-Forced Oil Cooled**

In cases where the daily load cycle varies widely, a triple rated transformer giving 66% additional load with all fans and pumps in operation may be indicated by an economic evaluation. The first stage with approximately ½ the cooling equipment in operation will give a 33% increase over the self-cooled rating for smaller peaks in the load cycle.

The fans and radiators are the same type as used on OA/FA units, however, the return flow from the radiators is collected into two or more headers at the bottom of the transformer tank and fed into 2½ hp oil pumps. The pumps force the oil into a baffled area beneath the coil assemblies and rapidly up through the coils. Pumps will be for operation on 230 volt single phase power supply furnished by the customer, unless specified otherwise. The pump motor and impeller are totally enclosed and oil immersed designed for long life with minimum maintenance.

The values for various stages of cooling are shown in PL 48-420.

**FOA Forced Oil-Forced Air Cooled**

This type of cooling is usually applied where the load is heavy and fairly constant and where the cost of power is minimum on the system. A typical example would be a generator step up transformer.

The FOA type of cooler has no rating without fans and pumps in operation. The heat exchanger is made up of a bundle of copper tubes with aluminum fins and is enclosed in a housing to direct the flow of air from the fan. The 1-hp fan motors and 2½ hp pump motors, unless specified otherwise, will be for 230 volt, single phase power supply furnished by the customer.

Oil flow inside the transformer tank through the coils is the same for OA/FOA/FOA or FOA. The kva rating specified for FOA units is the top continuous rating at either 55°C rise or 65°C rise. The 55°C rise rating can be operated continuously at 65°C rise and 12% more load.

**FOW Forced Oil-Forced Water Cooling**

The application of FOW cooling will be similar to FOA except an economical source of water for cooling must be available. The internal transformer arrangement and oil pumps will be the same as FOA and an oil to water heat exchanger will replace the FOA oil to air unit. The water supply must be under suitable pressure as no water pump is furnished on the transformer.

OA/FOA/FOA: FOA

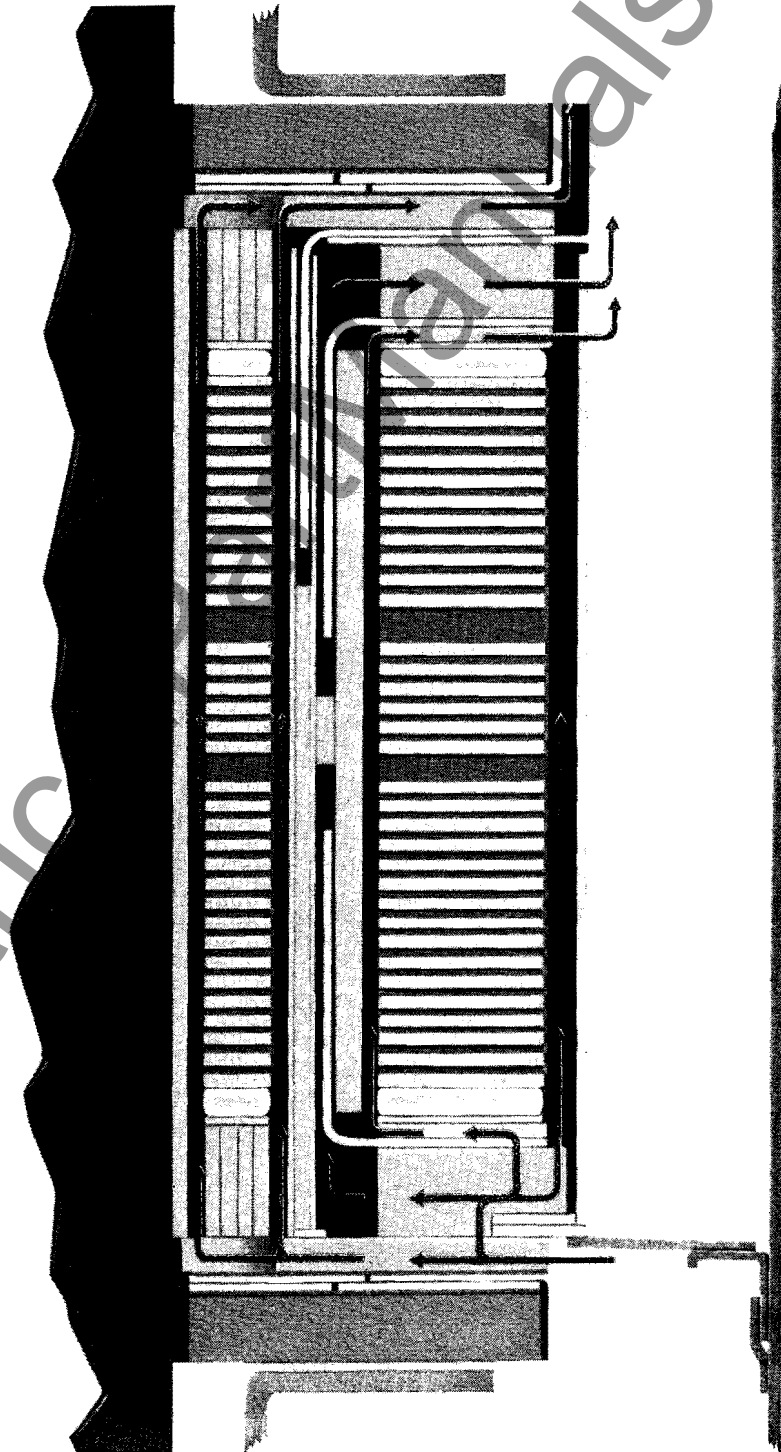

## Medium Power Transformers

OA, OW, OA/FA, OA/FA/FA,  
OA/FOA/FOA, FOA, FOW  
Three Phase: 10001 – 30000 Kva OA  
20000 – 50000 Kva FOA  
Single Phase: 10001 – 20000 Kva OA  
16667 – 33333 Kva FOA  
750 Kv BIL and Below

OA/FOA/FOA: Self-Cooled/Forced Air-Forced Oil Cooled

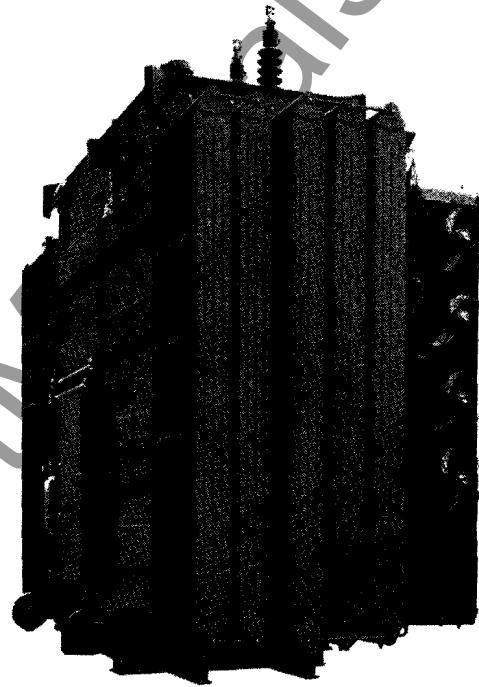
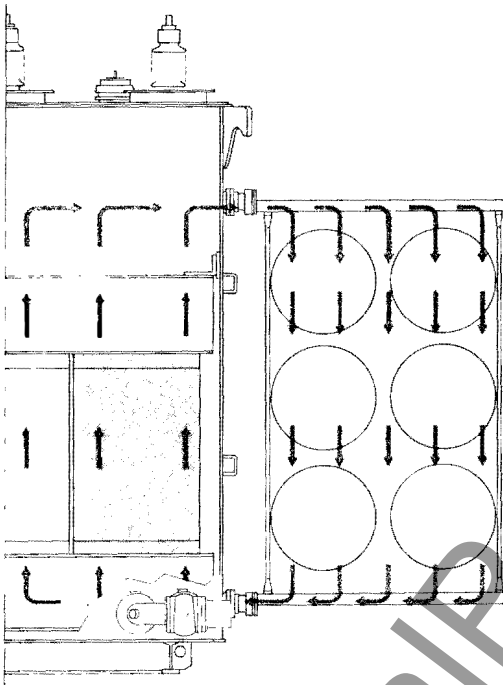

FOA: Forced Oil-Forced Air Cooled

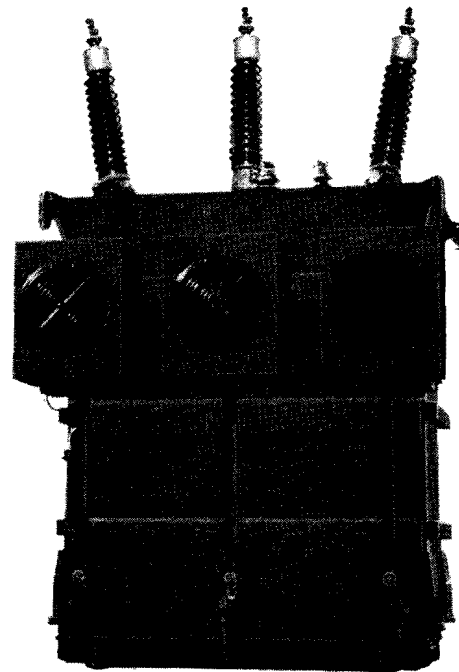
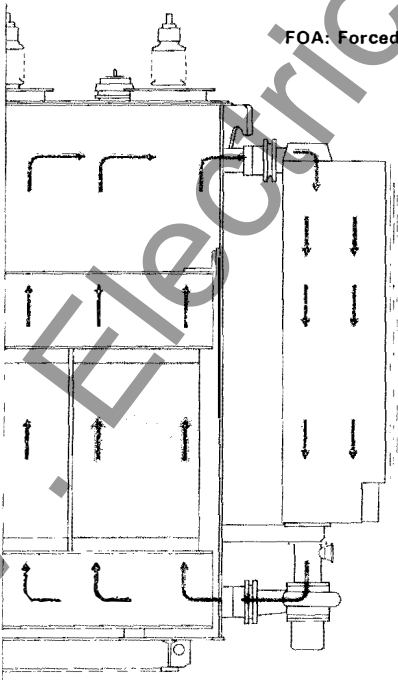

Westinghouse



**Optional Accessories**  
Type UTT Tap Changer

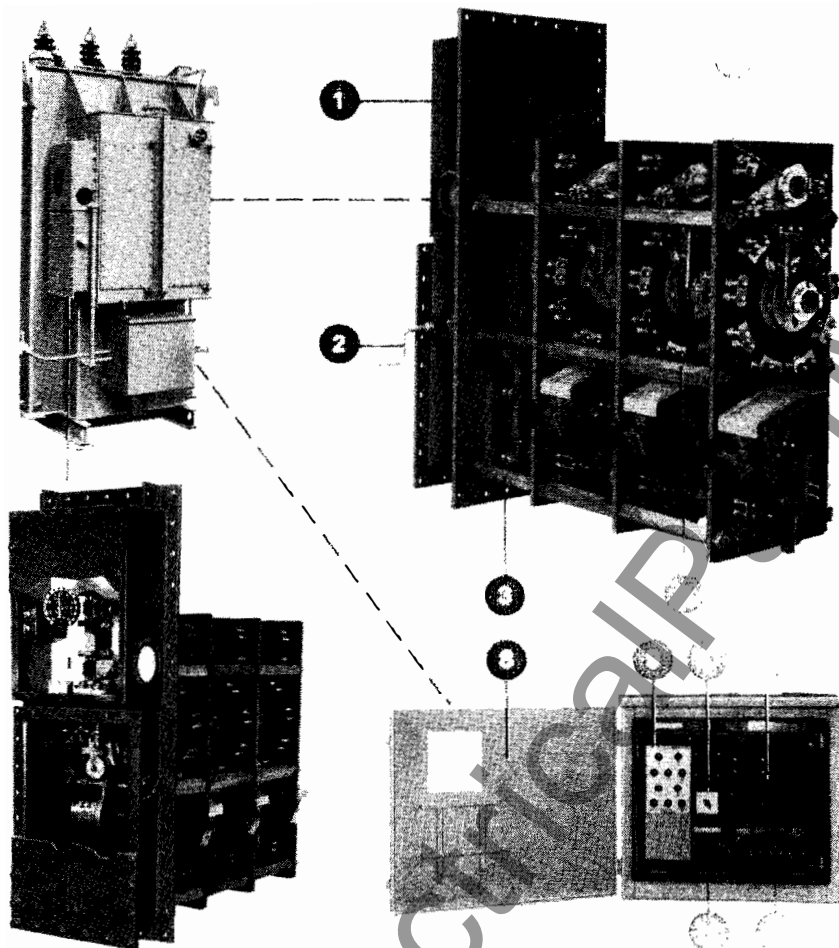

- 1 Steel End Plate
- 2 Hand Crank
- 3 Insulating Tie Rod
- 4 Reversing Switch Shaft
- 5 Selector Switch Shaft
- 6 Selector Stationary Contact
- 7 Transfer Switch

**Control Cabinet**

A large, weather tight, control cabinet is located near the tap changer mechanism.

- 8 Door swings clear and is equipped with maintenance record sheet and rack to hold instruction book, wiring diagram and other data.
- 9 Type SVC static relay (see page 11)
- 10 Paralleling switch (when specified)
- 11 Large control panel swings out for easy access to rear of panel and inside of control box.
- 12 Auxiliary transformer circuit breakers.
- 13 Sub-panel containing:
  - Contact signal light
  - Operation counter
  - Current test terminals
  - Potential test terminals
  - 15 ampere fuse
  - Relay test switch
  - Remote-local switch (if specified)
  - Auto-manual switch
  - Raise-lower switch
  - Position indicator reset button
  - Heater-on-off switch
  - Convenience outlet

The UTT Load Tap Changer uses the reactor switching principle with a selector switch making connection to the proper tap, aided by separate transfer switches, to perform the arcing duty of the switching operation.

The UTT Tap Changer is three phase and contains a motor, suitable gear reduction, a drive mechanism, spring-operated transfer switches, selector and reversing switches, position indicator, and other accessories.

The tap changer consists of three switches, one per phase, each positioned on a separate vertical Micarta panel. Each phase assembly contains a selector switch, reversing switch, and two transfer switches. The selector switches of all phases are driven by one insulating shaft from the operating mechanism.

A second shaft, timed to operate the transfer switches in the proper sequence, is located below the selector switch shaft. A third shaft operates the reversing switches which are mounted above the selector switches.

**Advantages**

Geneva gear positioning for accurate indexing and locking on position.

Mechanical and dual electrical stops for extra safety.

Fewer gaskets and easy access to all parts for reduced maintenance and inspection time.

Large Elkonite contacts for long life.

Easily accessible leads.

Unitized construction.

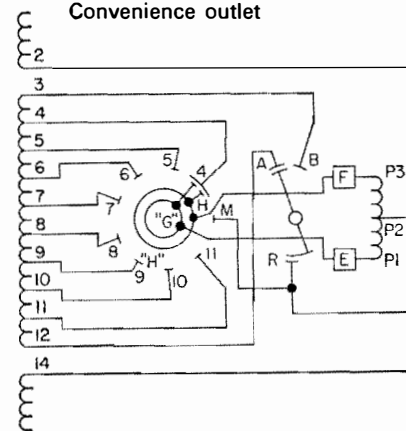

## Medium Power Transformers

OA, OW, OA/FA, OA/FA/FA,  
OA/FOA/FOA, FOA, FOW  
Three Phase: 10001 – 30000 Kva OA  
20000 – 50000 Kva FOA  
Single Phase: 10001 – 20000 Kva OA  
16667 – 33333 Kva FOA  
750 Kv BIL and Below

### Voltage Regulating Relay

The type SVC Voltage Regulating Relay is a factory calibrated control package designed to control load tap changers. It performs the functions of voltage sensing, time delay and line drop compensation with static devices that insure high reliability and low maintenance.

All settings are made by calibrated knobs on the front panel of the relay. The control components do not require warm-up time before making settings. Locking strips secure all continuously adjustable control knobs at the desired settings, and all other knobs are on snap-type tap switches which cannot move off position accidentally.

The relay accuracy is better than USA Standards Class 1.

All of the calibrated control knobs mount on the front of the SVC relay. The following settings can be made:

#### 1 Time Delay

The time delay can be set for raise and lower operation individually. It is continuously adjustable from 0 to 120 seconds with the dial positions marked for 5-15-20-60-90 and 120 seconds. There is also a Test position which has approximately zero time delay and which can be used to check the bandwidth settings.

#### 2 Balance Voltage

The balance voltage is adjustable from 105 to 134 volts in one volt steps. It is the sum of the values set on the Coarse and Fine control knobs.

#### 3 Bandwidth

The total bandwidth is continuously adjustable from 1 to 6 volts. The dial is calibrated for 1, 1.5, 2, 3, 4 and 6 volts at balance voltages of 105, 110, 115, 120, 125, 130 and 134 volts.

#### 4 Reactance Reversal

A control switch permits the reversal of the reactance portion of the line drop compensator for parallel operation of load tap changers by the reverse reactance method.

#### 5 Test Rheostat

The test rheostat can be used to provide a continuously adjustable voltage to the relay for testing.

### Line Drop Compensator

A. Reactance – Reactance compensation is adjustable in one volt steps from 0 to 24 volts.

B. Resistance – Resistance compensation is continuously adjustable from 0 to 24 volts.

Behind the front panel is a printed circuit board on which most of the static components are mounted. The printed circuit board mounts in a disconnect socket for ease of removal.

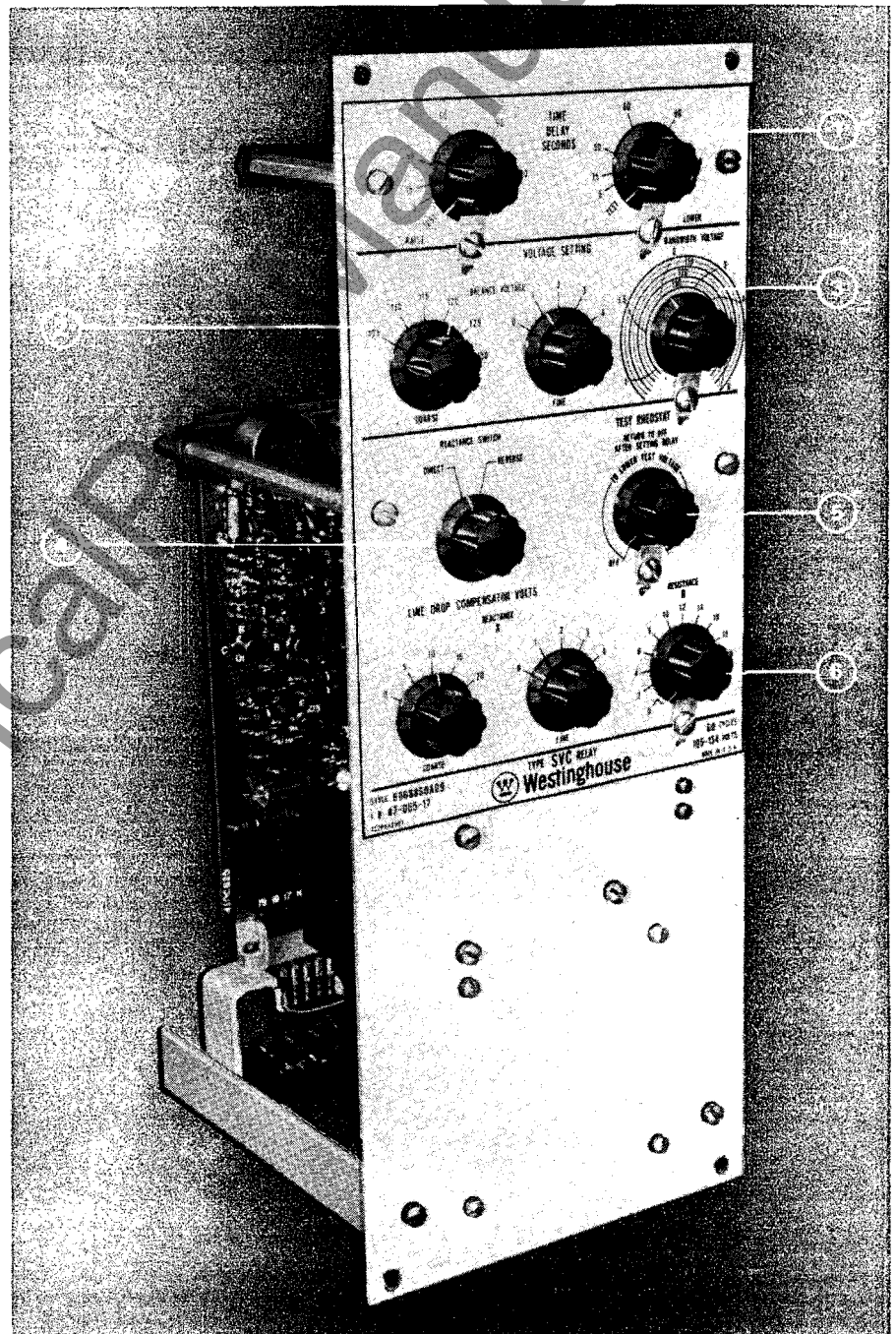

Westinghouse



Optional Accessories, Continued  
Bushing-Type Current Transformers

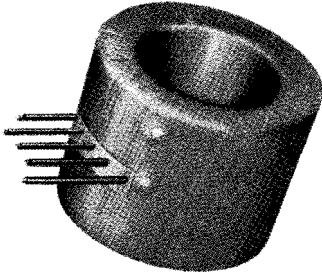

Multi-ratio current transformers are applied for general application involving protective relays and indicating instruments. These can be included in the power transformer case on the bushing flange, or provision can be made for future installation by the user. Tap ratios, current ratings and accuracy are according to NEMA standards.

NEMA Standard Ratings for  
Bushing-Type Current Transformers

40	50	10	20	600/5	100	300	200	3000/5
80	100	20	40	1200/5	200	200	400	4000/5
100	60	160	80	2000/5	200	200	600	5000/5
X5	X4	X3	X2	X1	X4	X3	X2	X1

Standard Primary Current Amps	BCT Standard Ratios
600	120/100/90/80/60/50/40/30/20/10:1
1200	240/200/180/160/120/100/80/60/40/20:1
2000	400/320/300/240/220/160/100/80/60:1
3000	600/400/300:1
4000	800/600/400:1
5000	1000/800/600:1

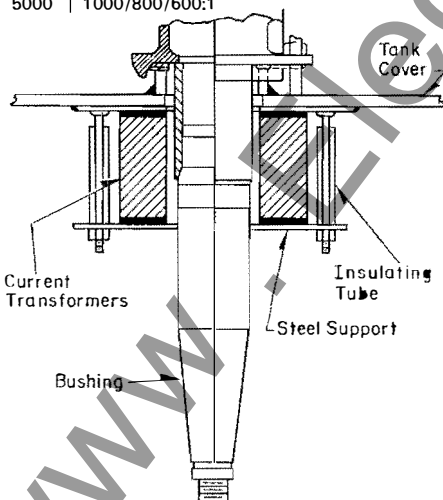

Dial Hot Spot

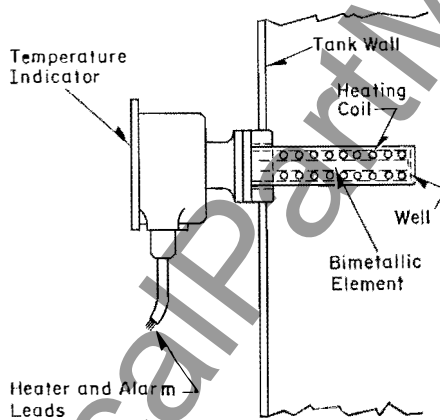
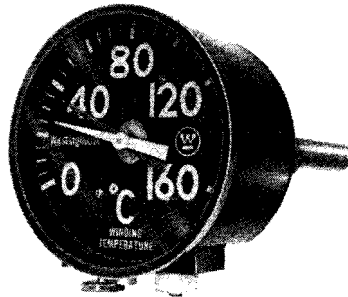

Dial hot spot winding temperature equipment including a current transformer may be specified. Energy from a current transformer added to the temperature of the top oil in the tank operate a bimetallic element to indicate the simulated hot spot temperature of one phase of the transformer winding. A pointer on the large weatherproof indicator dial gives visual indication, and switches are provided to actuate cooling equipment and to control alarm circuits.

Inertaire System

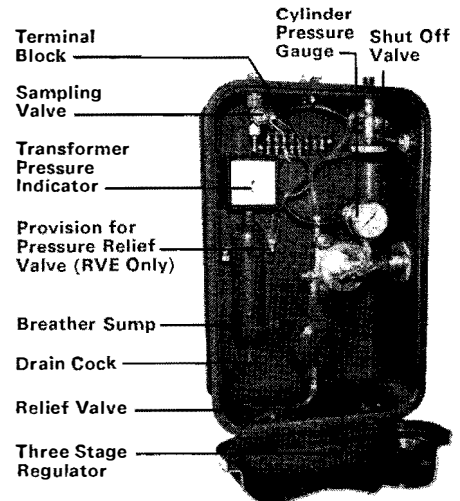
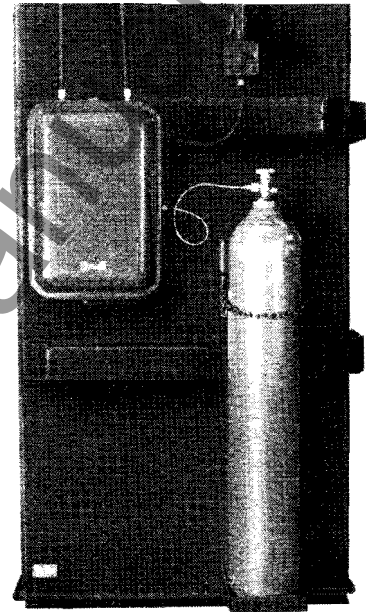

Inertaire equipment maintains dry nitrogen under a light positive pressure in the gas space above the oil regardless of thermal cycling of the unit or external ambient conditions.

## Medium Power Transformers

OA, OW, OA/FA, OA/FA/FA,  
OA/FOA/FOA, FOA, FOW  
Three Phase: 10001 – 30000 Kva OA  
20000 – 50000 Kva FOA  
Single Phase: 10001 – 20000 Kva OA  
16667 – 33333 Kva FOA  
750 Kv BIL and Below

### Throat Connections

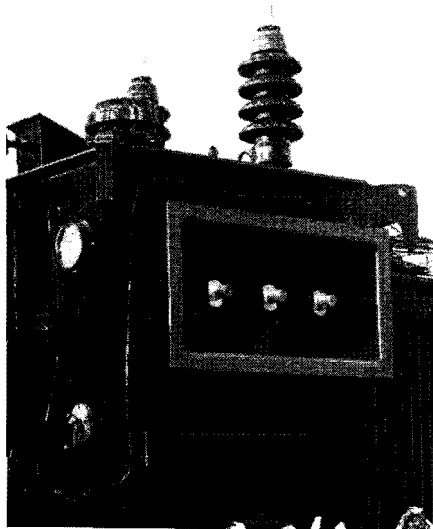

Bushing groups may be enclosed in a flanged throat for connection to switchgear or bus duct. Segregated or isolated phase throat assemblies are also available.

### Terminal Chambers

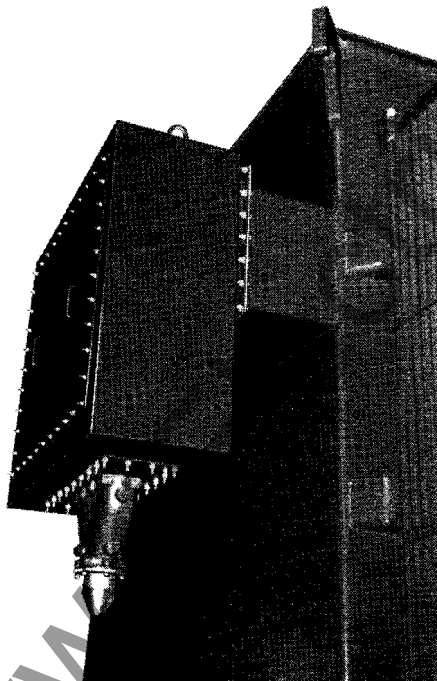

Two types are available for enclosing cable connections:

1. High voltage and/or low voltage terminal chambers for cable entrance, with or

without potheads, for voltages of 69 kv and below. Air-insulated chambers are usually used for all voltages 15 kv and below; oil chambers for all voltages above 15 kv. (Illustrated terminal chambers and pothead.)

2. High voltage and/or low voltage terminal chamber with pothead and with mag-break disconnecting switch.

### Sudden Pressure Relay

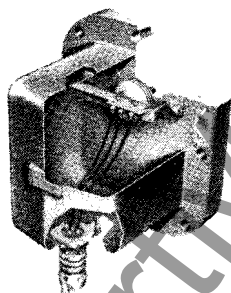

Protection against damage due to internal fault can be provided by a sudden pressure relay. This device operates on rate of pressure change; that is, the higher the rate of rise, the faster it operates. It will not operate on pressure changes due to changes in transformer temperature or loading, but it will protect against small arcs which would not cause a relief device to operate. On major troubles causing high rate of rise, it will operate within a half-cycle on a 60-cycle circuit. It is not sensitive to mechanical shock or electrical disturbances which cause no internal damage to the transformer.

### Combustible Limit Relay

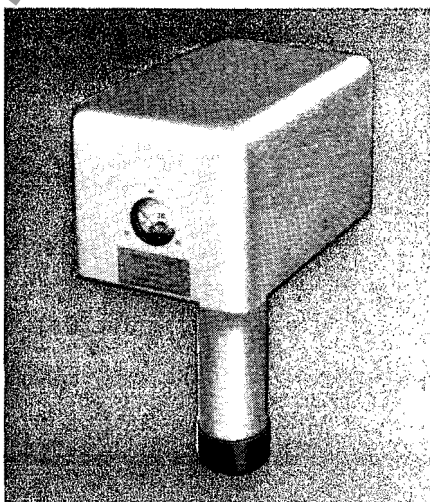

The Westinghouse Combustible Limit Relay (CLR) automatically tests the atmosphere in an INERTAIRE® power transformer and will actuate an alarm circuit if the combustible

gas content over the surface of the oil reaches a predetermined danger level, thus warning of a possible internal fault.

### Lightning Arresters

Maximum surge protection is provided by installation of lightning arresters mounted directly on transformer tank brackets.

Westinghouse intermediate or station type arresters may be specified and furnished with the transformer or the transformer furnished with arrester brackets only for mounting customers' arresters.

### Standard Tests

The following tests are made on all core-form transformers in accordance with USA Test Code for Transformers:

1. Resistance measurements of all windings on the rated voltage connection of each unit and at the tap extremes of one unit only of a given rating on an order.
2. Ratio tests on the rated voltage connection and on all tap connections.
3. Polarity and phase-relation tests on the rated voltage connection.
4. Excitation loss at rated voltage on the rated voltage connection.
5. Excitation current at rated voltage on the rated voltage connection.
6. Impedance, voltage and load loss at rated current on the rated voltage connection of each unit and on the tap extremes of one unit only of a given rating on an order.
7. Temperature test:
  - A. Temperature test or tests will be made on one unit only of an order covering one or more units of a given rating. Tests will be made only when there is not available a record of a temperature test on a duplicate or essentially duplicate unit.
  - B. Subject to the limitations of the preceding paragraph (A), when a transformer is supplied with auxiliary cooling equipment to provide one additional kva rating, temperatures tests will be made on both nameplate kva ratings.
8. Applied potential tests.
9. Induced potential tests.

## Medium Power Transformers

OA, OW, OA/FA, OA/FA/FA,  
OA/FOA/FOA, FOA, FOW

Three Phase: 10001 – 30000 Kva OA  
20000 – 50000 Kva FOA

Single Phase: 10001 – 20000 Kva OA  
16667 – 33333 Kva FOA

750 Kv BIL and Below

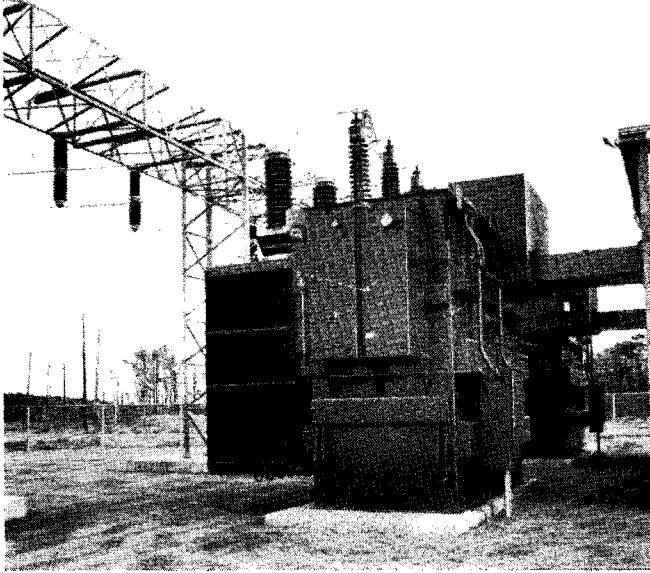

Typical Industrial Transformer

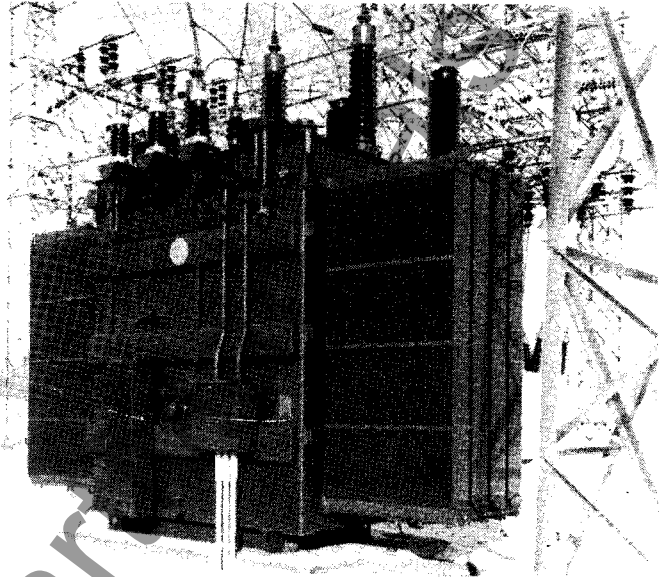

Typical Utility Substation Transformer

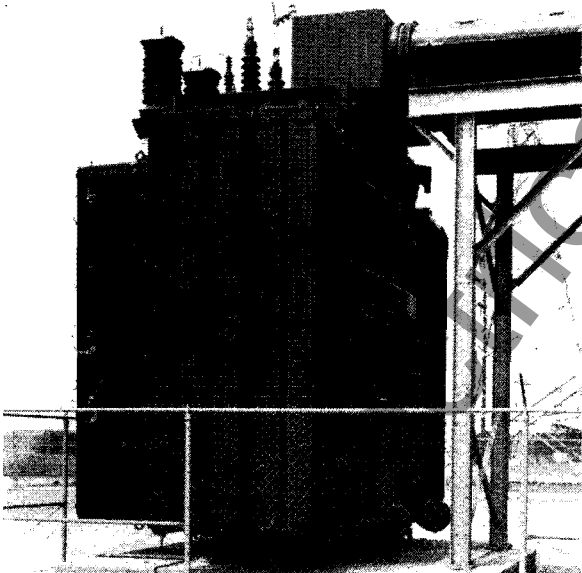

Typical Generator Transformer

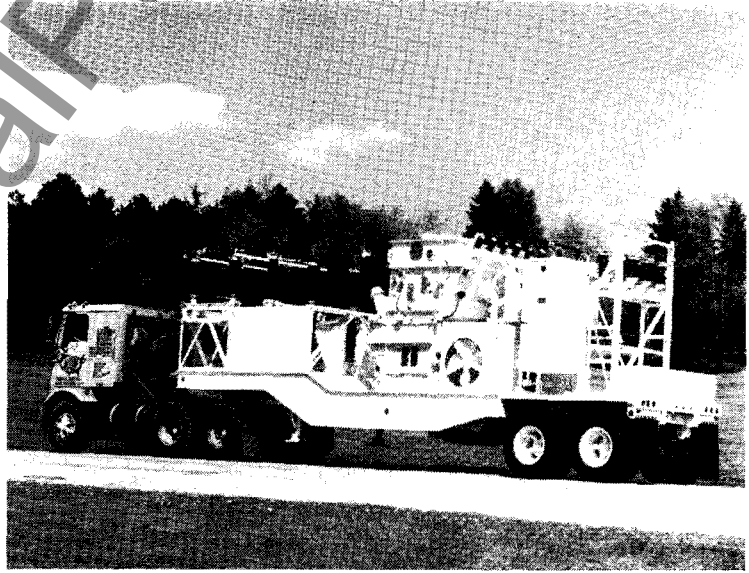

Typical Mobile Transformer

### Further Information

Price List, Med. Power Trans.	PL 48-420
Substation Transformers	DB 48-150
CSP Transformers	DB 48-250
Mobile Transformers	DB 48-350
UTS and UTT Regulators	DB 47-550
Large Power Transformers	DB 48-650

Data contained in this publication is subject to change without notice.

**Westinghouse Electric Corporation**  
Power Transformer Division, Sharon, Pa. 16146  
Printed in USA



## Medium Power Transformers

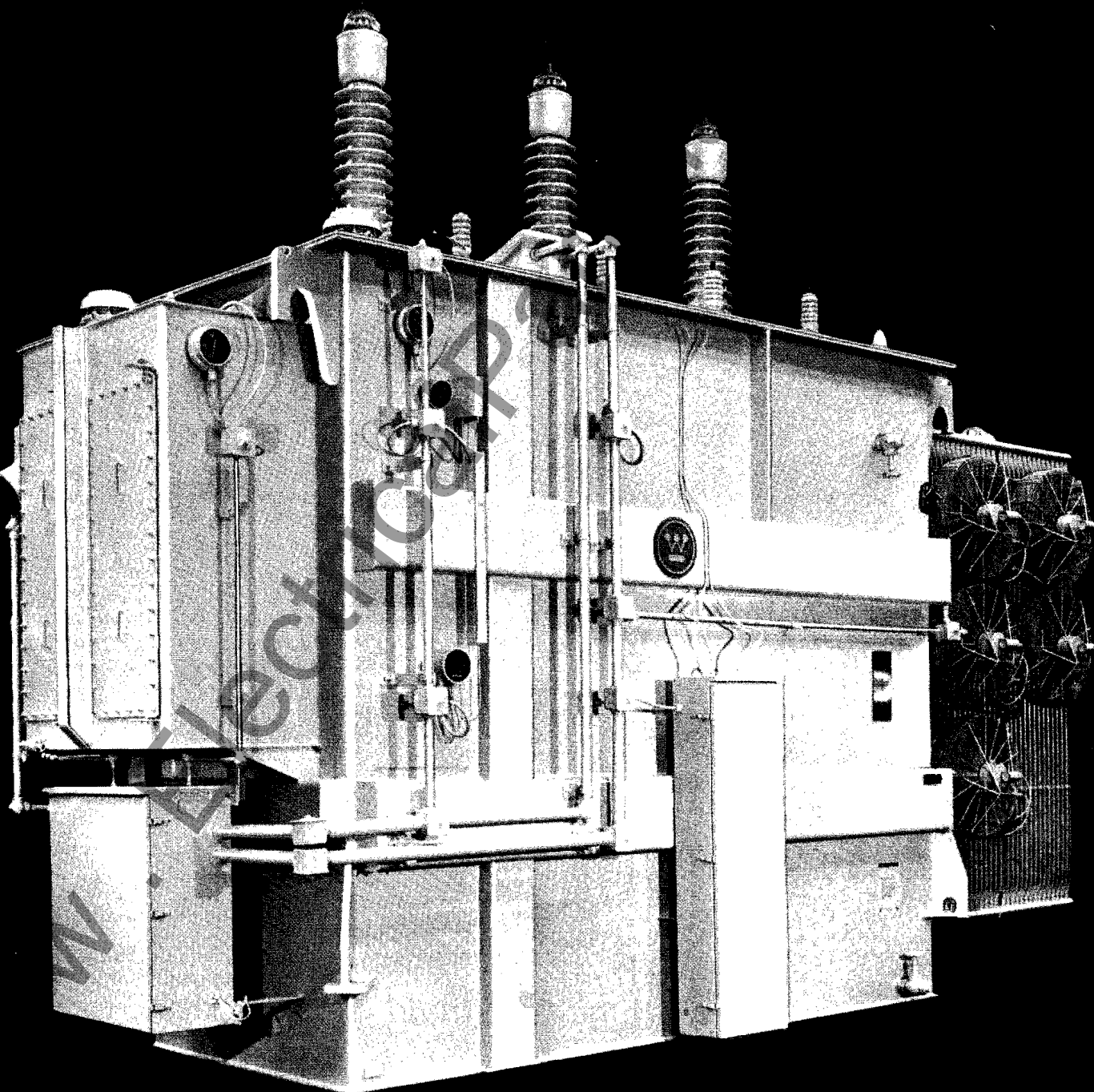
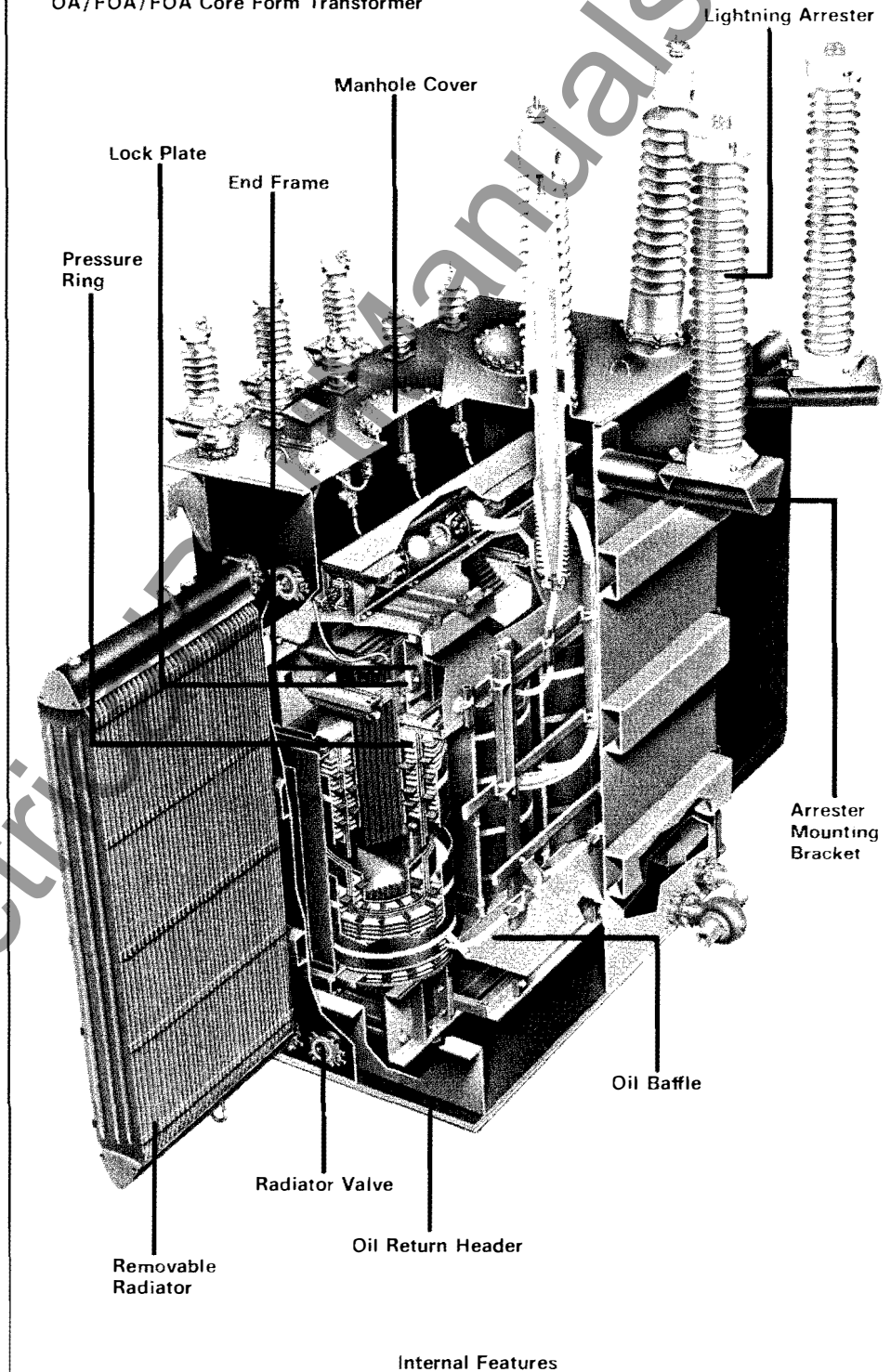

Table of Contents	Page
Application and Design Standards . . .	3
Features . . . . .	2-3
Advantages . . . . .	3
Reliability . . . . .	4
Design . . . . .	4
Selection of Materials . . . . .	4
Assembly . . . . .	6
Testing . . . . .	7
Mechanical Strength . . . . .	9
Dielectric Strength . . . . .	10
Thermal Capacity . . . . .	12
Load Tap Changing . . . . .	14
Bushings . . . . .	18
Protection and Fault Detection . . . .	20
Standard Features . . . . .	21
Optional Features . . . . .	22
Transporting . . . . .	23
Drawings and Instruction Books . . . .	23
Westinghouse Firsts In Transformer Development . . . .	24

Cutaway View of a Typical  
OA/FOA/FOA Core Form Transformer



www.ElectricalManuals.com



### Application and Design Standards

Westinghouse offers a complete line of medium power transformers capable of handling the wide range of load conditions

characteristic of generating stations and substations. Transformers are available in each class of cooling: as auto transformers; with more than two windings; with zig-zag windings; with or without load tap

changers; and with other variations to meet specific system needs. Typically, they are applied: as generator step-up, mobile, station auxiliary and station startup transformers, in stationary or mobile substations; and to serve mine sleds, captive motors, arc furnaces, and glass melting furnaces, rectifiers and regulators. All are designed in accordance with ANSI Standard C57-12.00.

Figure 1. A Westinghouse transformer

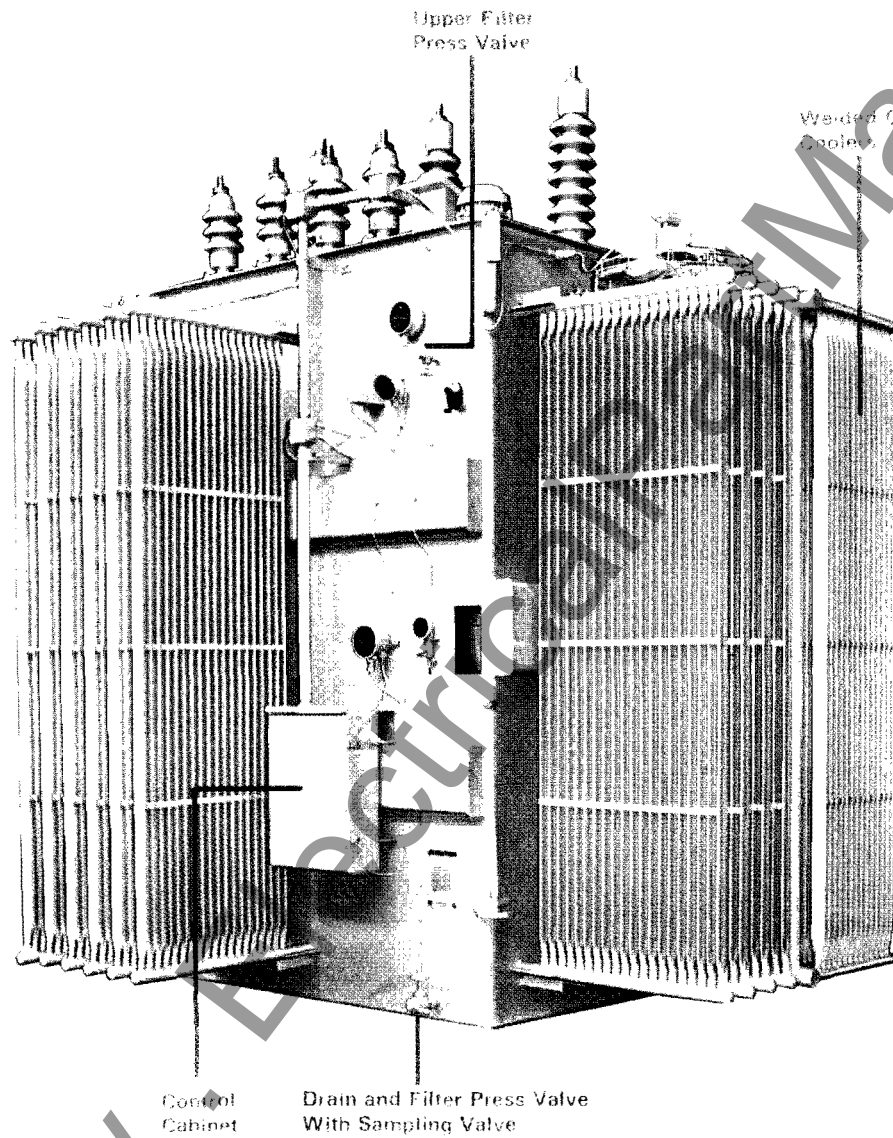

External Features

### Ratings

**KVA:** 5001 through 60,000 OA, 3 phase  
20,000 through 100,000 FOA, 3 phase  
3,334 through 40,000 OA, 1 phase  
16,667 through 66,667 FOA, 1 phase

**Frequency:** 25, 50 or 60 Hertz

**Voltage:** Through 900 KV BIL

**Temperature:** 55/65° or 65°C

### Advantages

**Efficiency and reliability.** Advanced engineering technology and manufacturing techniques, including use of computer programs and automated production processes, result in coordinated designs which emphasize operating efficiency and reliability yet minimize size and weight.

**Maximum short circuit strength.** Laboratory developed and tested designs assure the ability of Westinghouse transformers to repeatedly withstand the short circuit currents inherent to modern power systems.

**Maximum thermal capacity.** Improved Insuldur® insulation ages more slowly and retains dimensional stability under elevated temperatures. WEMCO-C oil resists oxidation and sludge formation and retains maximum insulating and cooling characteristics. Both contribute to outstanding transformer life and load handling ability.

**Maximum dielectric strength.** Windings, solid insulation and oil are selected and arranged in a manner to: create a low ratio of coil to ground capacitance versus series capacitance, eliminate creepage paths so that puncture strength is utilized, and to balance stresses of solid and liquid insulation in series. The result is uniform stress distribution, elimination of corona, and maximum dielectric strength.

**Less costly to handle and install.** Compact sizes reduce the costs of rigging and hauling, and require smaller installation pads.

**Less costly to maintain.** Orderly tank designs and simplified accessories improve access and reduce maintenance

com

**Reliability: Design, Materials, Assembly and Testing of Westinghouse Transformers**

Reliability of Westinghouse transformers is measured by their useful service. In turn, useful service depends on such characteristics as mechanical strength, dielectric strength and thermal endurance, all of which are determined by design, selection of materials, assembly and testing.

**Design**

Advanced computer programs are used in analyzing the electrical and mechanical stresses in transformers. Formulas are developed from data derived using low voltage repetitive surge generators and winding models.

Surge distribution and field analysis are used to determine electrical stresses.

Material characteristics are determined by testing at Sharon and Westinghouse Research and Development Center. Complete dielectric tests verify insulation designs.

Magnetic flux leakage can cause excessive local heating if not controlled. The complex problems which must be solved to control leakage flux are solved by computer analysis using information obtained through research in flux field mapping. Design criteria are verified using prototype transformers, and leakage field calculations are made on all large transformer designs to assure reliability.

**Selection of Material**

• **Conductors.** Westinghouse was the pioneer in use of aluminum for windings and over 20,000 transformers with aluminum windings, built since 1952, are in service. Equivalent designs using copper or aluminum are available and have equal reliability. Conductor material is selected to provide the maximum performance and reliability at an economical cost, as determined by a computer program which optimizes design.

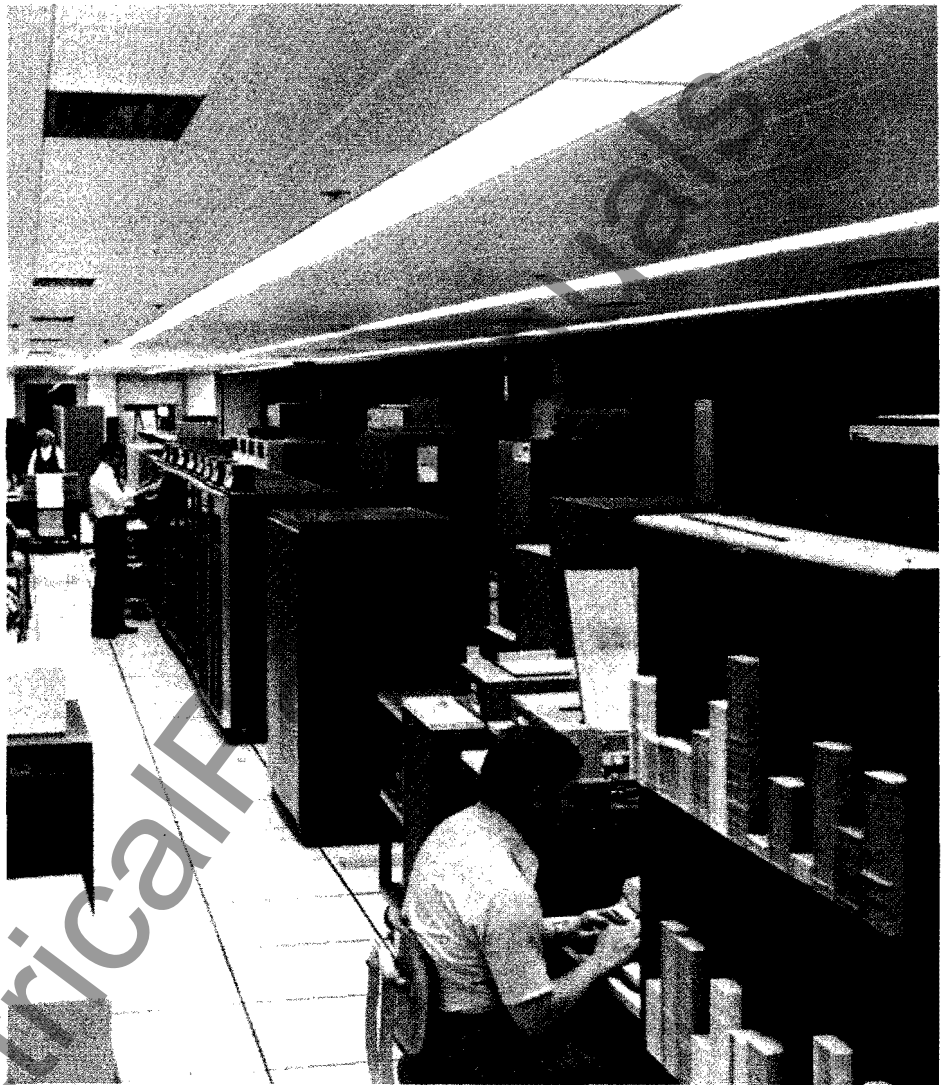

Computer Room

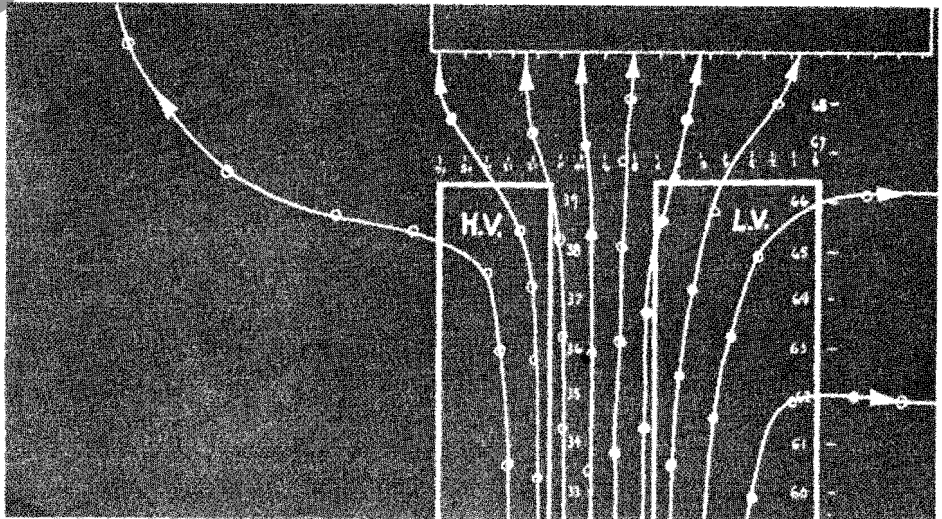

Magnetic Field Investigations

WWW.Electrical.com



\* **Electrical Steel.** Cores are made of Hipersil laminations with Carlite coating. Hipersil is a cold rolled, grain oriented, highly permeable steel which accommodates flux densities  $\frac{1}{4}$  higher than non-oriented electrical steel. Carlite is a non reacting interlaminar insulation that reduces core losses, and permits improved performance and size reduction.

\* **Conductor Insulation**

1. **Cellulose.** The paper used to insulate winding conductors is a thin, high puncture strength paper with Insuldur® treatment for superior thermal performance. When extra mechanical protection is required for the insulation, the outer layer of tape is a dense crepe paper. The crepe paper has characteristics similar to the other layers, but is tougher, more flexible, and less subject to mechanical damage.

2. **Powder Coated Insulation.** The conductor is insulated with a powder coating applied in a continuous process using an electrostatic spray coating method. The tough, abrasion resistant coating replaces paper in many applications, has excellent dielectric strength and is less compressible than paper.

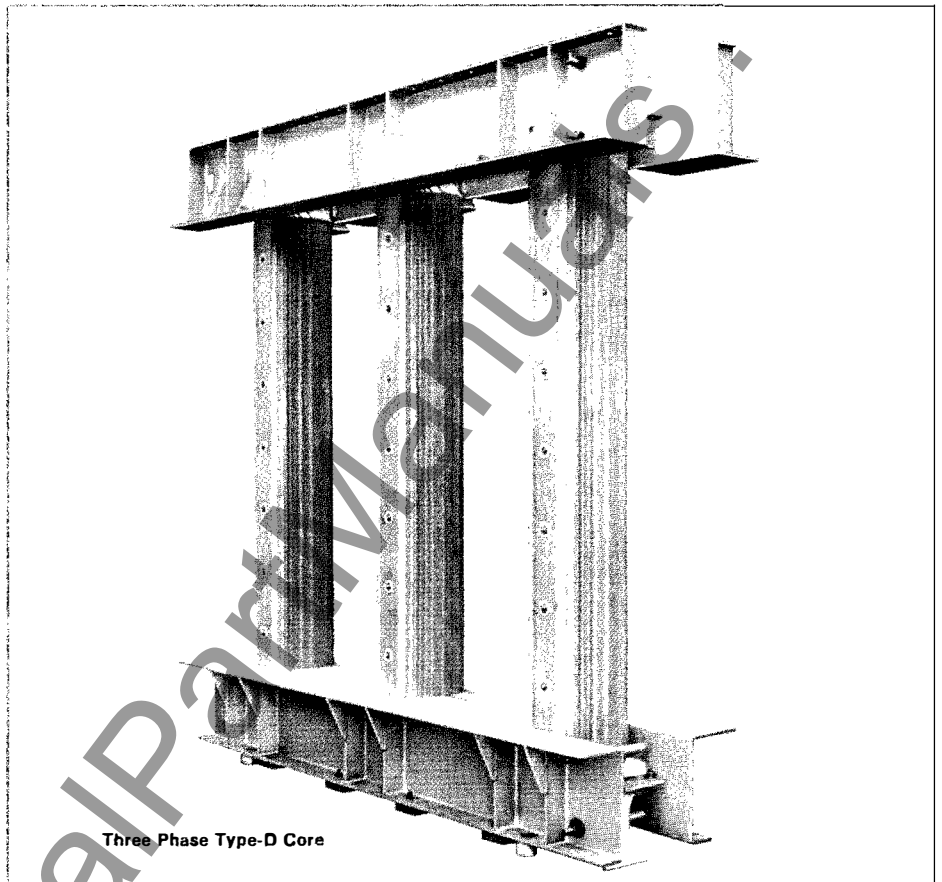

Three Phase Type-D Core

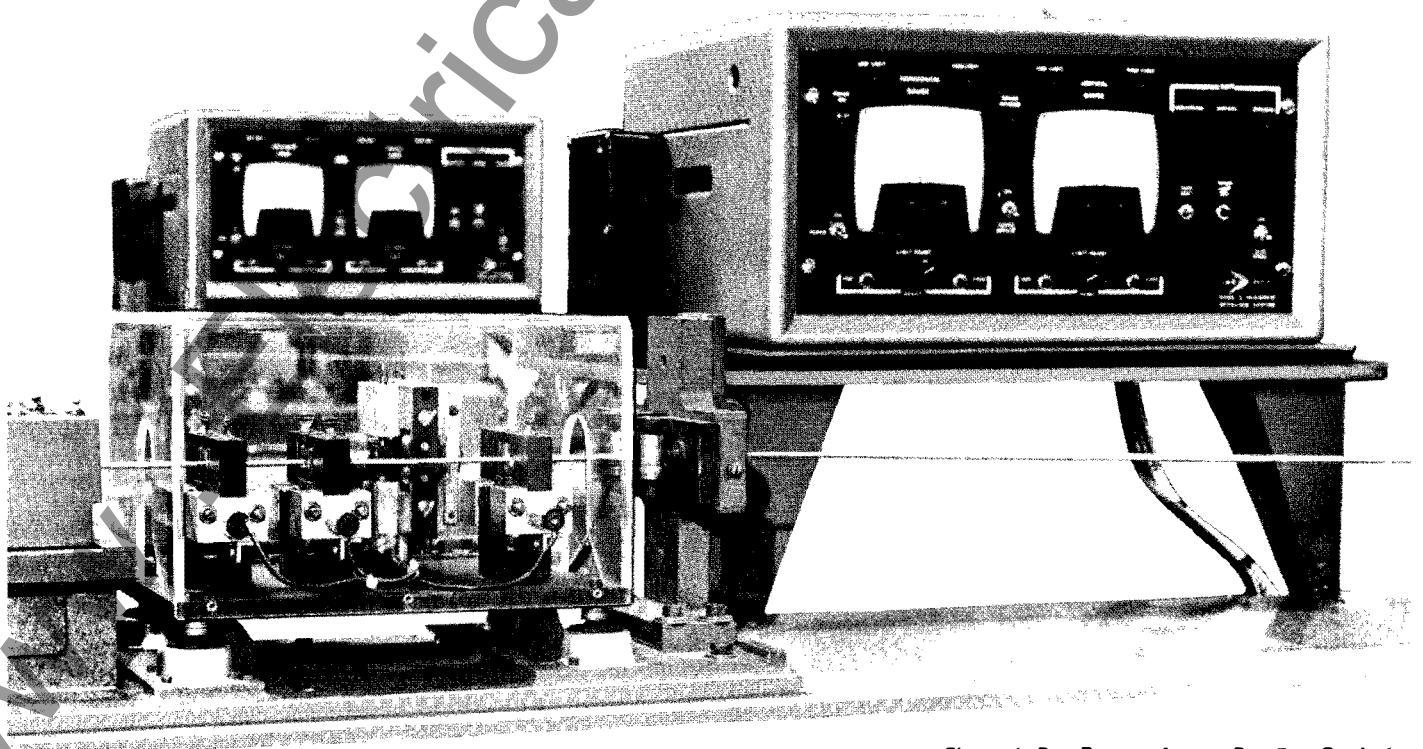

Electronic Burr Detector Assures Burr Free Conductor

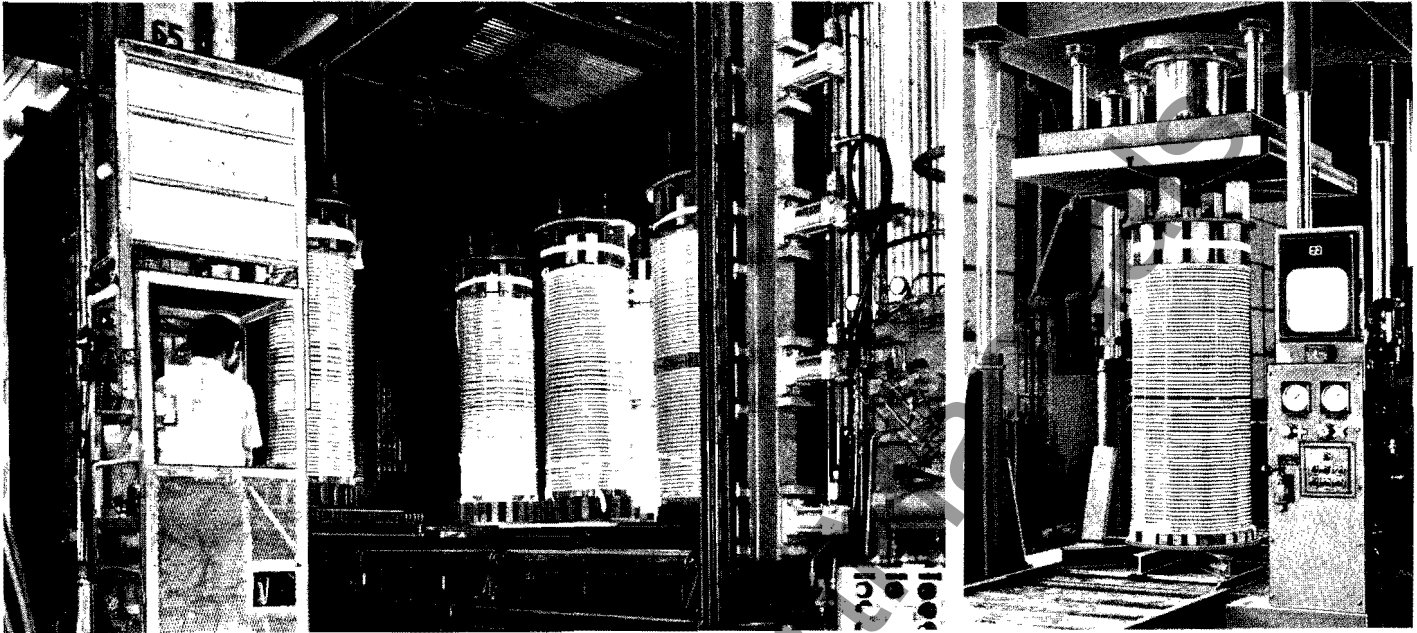

Vapotherm Treatment Equipment

Hydraulic Press for Compression of Coils to Design Height

Vapotherm Drying. Coils and pressboard insulation are dried in an oxygen free atmosphere. During drying, the heat of vaporization, released by a hydrocarbon solvent, is transferred directly to moisture in the material being dried; the result is rapid, uniform drying throughout the coil without danger of destructive overheating. When dry, and while under vacuum, the coils are impregnated with dry transformer oil. Then, to assure mechanical reliability, they are hydraulically compressed under the calculated short circuit force and adjusted to the designed coil height.

Tight Assembly. After vapotherm processing, the coils are lowered over the legs of the core onto the bottom end assemblies; top end assemblies are positioned and the core is yoked. After the end frames and insulation pieces are positioned, a special fixture hydraulically applies pressure, compressing the coils to the design height. Locking keys are then inserted between the wide flange end frames and core leg lock-plates to maintain height and pressure without stressing the core laminations.

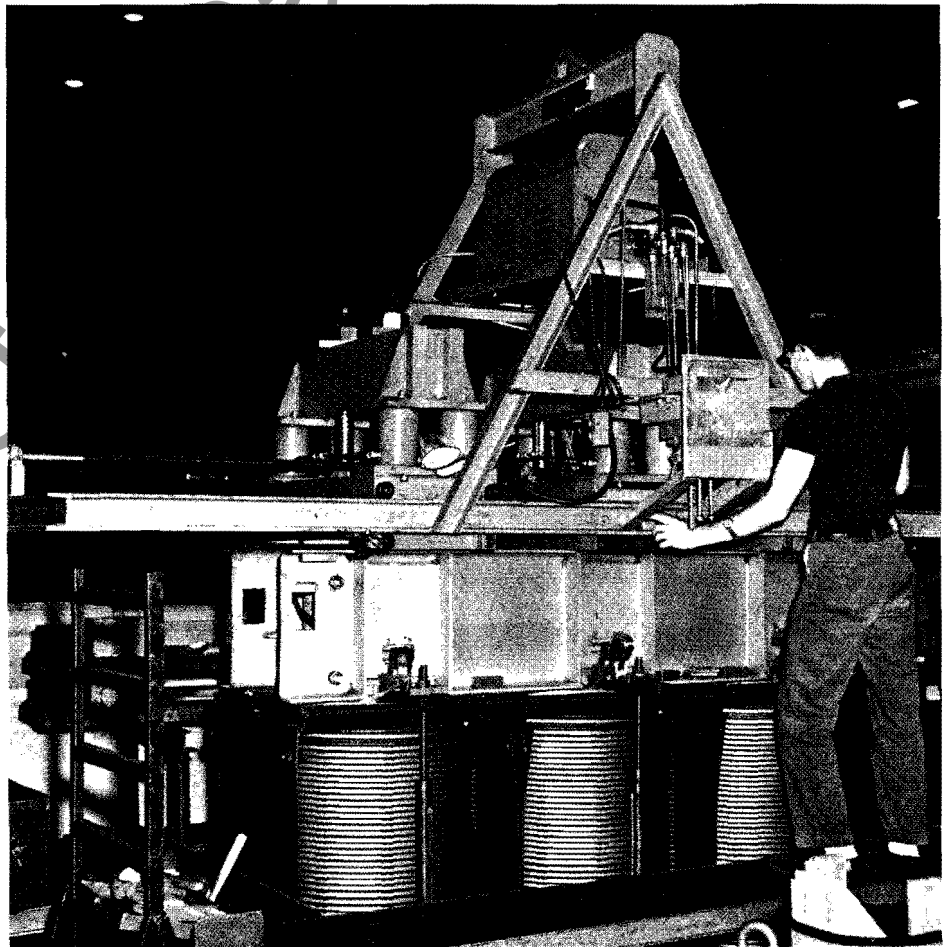

Compression Fixture for Looking End-frames

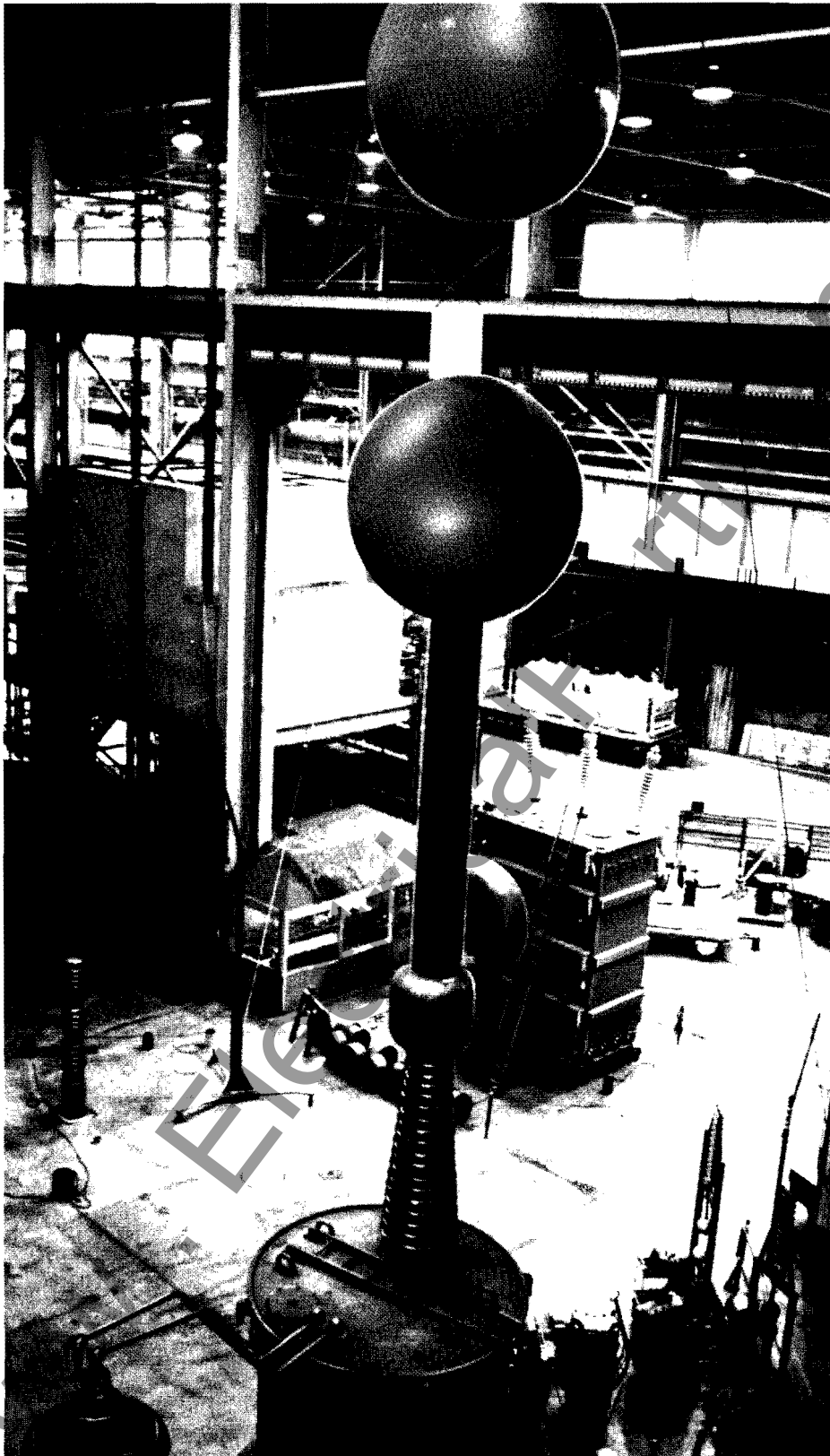

#### Testing

Westinghouse is equipped to conduct all applicable ANSI, NEMA and IEEE transformer tests. Ten standard and seven optional tests are offered.

- Standard tests. All Westinghouse transformers are subjected to the following tests, all comply with the latest revisions of ANSI Standard Test Code C57. 12.90.

1. Resistance measurements of all windings on the rated voltage connection of each unit, and at the tap extremes of one unit of a given rating on a single order.
2. Ratio test on the rated voltage and all tap connections.
3. Polarity and phase relationships on the rated voltage connections.
4. No-load loss at rated voltage on the rated voltage connection.
5. Exciting current at rated voltage on the rated voltage connection.
6. Impedance and load loss at rated current on the rated voltage connection of each unit, and on the tap extremes of one unit of a given rating and order.
7. Temperature test or tests are made on one unit of a given rating and order only when a record of a similar test on a similar or identical unit is unavailable. When auxiliary cooling is supplied to provide more than one KVA rating, temperature tests will be made only at the 55°C OA rating, and at the maximum 65°C supplementary rating, or 65°C FOA ratings.
8. Applied Potential
9. Induced Potential
10. Insulation Power Factor

• Optional tests. Seven tests can be made.

1. NEMA front of wave impulse
2. Switching surge
3. Audio sound level measurement
4. ANSI impulse
5. Short Circuit Test
6. Quality Control impulse test. When ANSI tests are not called for and if necessary, quality control impulse tests may be made to prove a design above 350 KV BIL and 10 MVA OA. The test consists of a reduced full wave and two chopped waves followed by one full wave. Crest values have a  $\pm 5\%$  tolerance as compared to ANSI which allows only a  $+5\%$  tolerance.
7. Corona tests consist of an RIV measurement on the HV winding terminals during the induced test. The measurement procedure and instrumentation comply with "NEMA 107—Methods of Measuring Radio Noise"; except that the power supply is connected to the lowest voltage winding, and the bushing capacitance tap is usually used to connect the RI meter to the HV terminal.

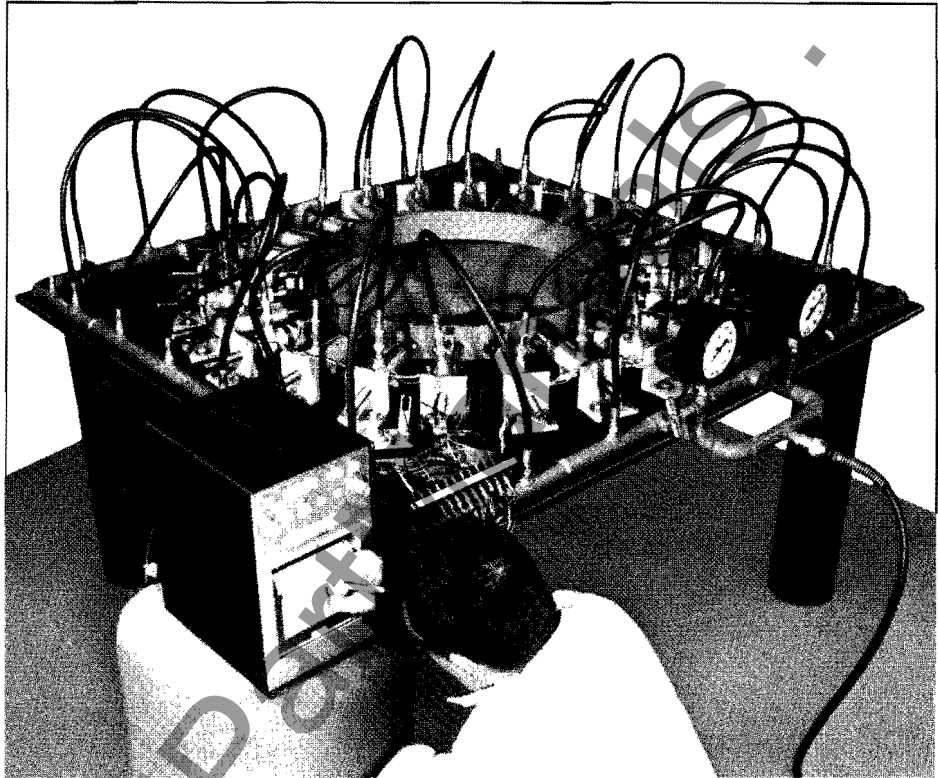

**Winding Tube Compression Test**

A continuing program of quality control testing and short circuit testing of complete units as well as the components assures the design integrity.

**Short Circuit Tests of Westinghouse Power Transformers**

Year	KVA	Phase	High Voltage	Low Voltage	Impedance	Conductor Material	
						HV	LV
1954	500	3	13.8 KV	216 V	4%	Cu	Cu
1959	333	1	13.8 KV	216 V	5%	Cu	Cu
1959	2000	1	36.2 KV	2400 V	4%	Cu	Cu
1959	2500	3	13.8 KV	216 V	5%	Cu	Cu
1963	10000	3	43.8 KV	13900 V	11%	Cu	Cu
1964	500	3	27 KV	216 V	4.1%	Cu	Cu
1965	800	3	11.2 KV	4160 V	5.6%	Cu	Cu
1966	1667	1	12 KV	2400 V	5.5%	Cu	Cu
1967	3333	1	13.8 KV	2400 V	3%	Cu	Cu
1967	25000	3	110 KV	20000 V	8.3%	Cu	Cu
1970	10000	3	41 KV	4800 V	6.2%	Cu	Cu
1971	1667	1	34.4 KV	7200 V	6.1%	Cu	Cu
1972	7500	3	69.0 KV	13090 V	6.9%	Al	Al
1973	15000	3	67 KV	12470 V	7.0%	Cu	Cu
1973	10000	3	115 KV	23000 V	4.7% (5 MVA)	Al	Cu
1973	15000	3	39.5 KV	13800 V	6.5% (5 MVA)	Al	Cu
1973	15000	3	39.5 KV	13200 V	7.0%	Al	Cu
1974	7500	3	115 KV	12400 X 13800 V	7.0%	Al	Al

A major program of short circuit test has been conducted for 20 years. To prove the design concepts and construction, production units have been given multiple short

circuit tests to full rated capacity in the Westinghouse high power laboratory in East Pittsburgh, Pennsylvania.



## Mechanical Strength

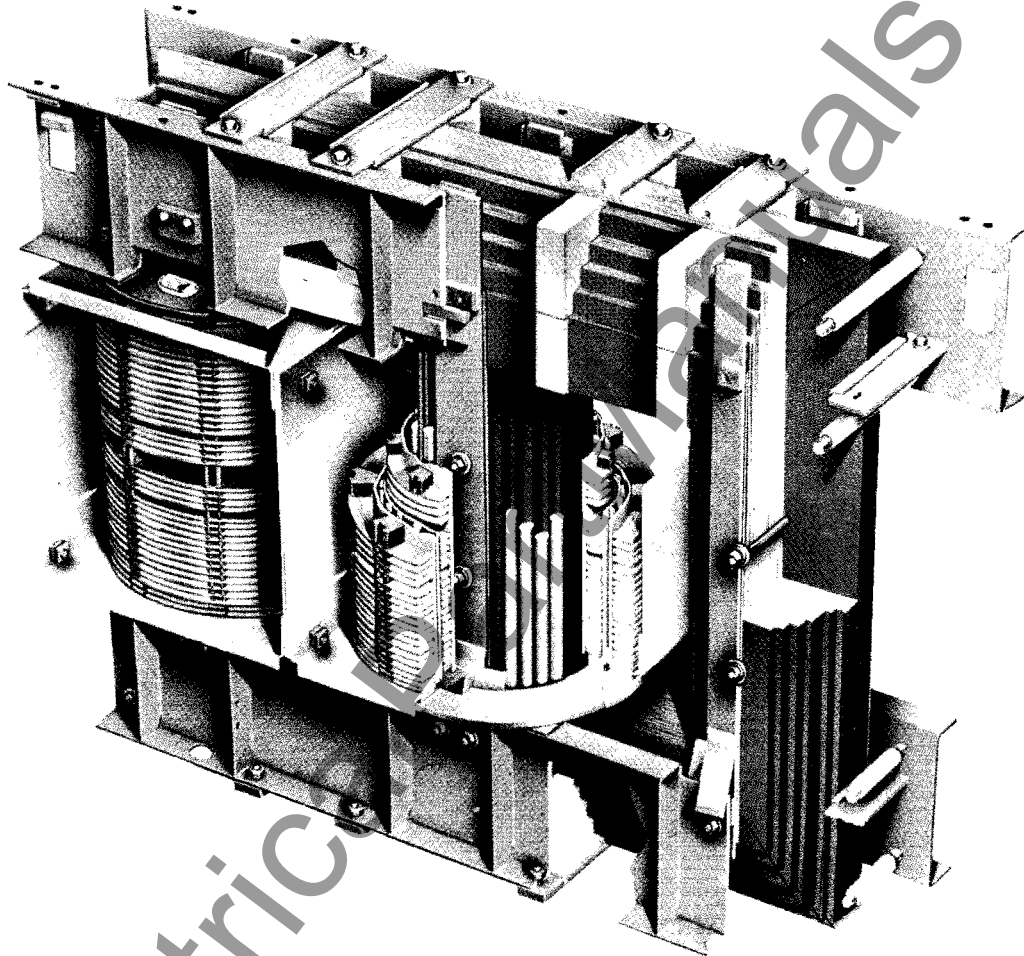

### The Need for Rigidly Braced Core and Coil Assemblies.

Westinghouse transformers are designed to withstand the mechanical forces of line faults and to survive vibration and shock during shipment. Core and Coil assemblies are rigidly braced, special manufacturing techniques are used and the newest insulating materials are incorporated.

Transformers in service encounter more frequent and severe short circuit forces as power systems increase in size and complexity. Short Circuit forces are large in both horizontal and vertical directions. Horizontal forces cause the low voltage coil to compress against the core, and the high voltage coil is stressed in tension. Vertical forces are caused by radial flux components and axial displacement of the electrical center lines. A displacement of  $1\frac{1}{2}\%$ , caused by such factors as taps and manufacturing tolerances, may create a

force of several hundred thousand pounds under a through fault condition.

### Horizontal Bracing

Coils are concentrically assembled on the core legs and rigidly braced laterally against the core, or on self supporting insulating cylinders.

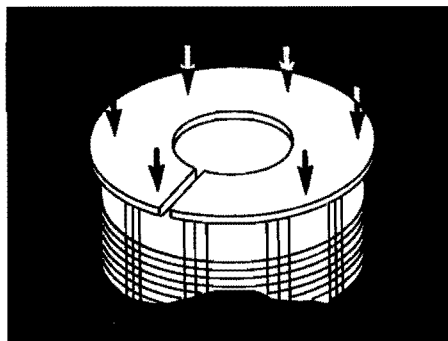

Pressure Ring

### Vertical Bracing

Three carefully coordinated structural links prevent vertical coil movement.

**Lock plates** adjacent to the core and locked to end frames are in tension from forces tending to separate end frames.

**End Frames** are interlocked to lock plates and restrain pressure rings.

**Plate Type Pressure Rings** distribute forces uniformly from coils to end frames. Rings of solid plate carbon steel are used where moderate magnetic flux density are encountered. Filament wound glass epoxy rings replace solid steel in applications where flux concentrations might cause overheating in solid steel plates. Rings produced by winding interlocking strips of Carlite coated high permeability sheet steel are used where forces and flux densities are large. Lamination surfaces are parallel to flux lines to reduce stray losses.

**Dielectric Strength**

With increased system size and complexity the exposure of each transformer increases, and the reliability of each transformer affects to a greater extent the reliability and integrity of the system.

**Coil Construction and Insulation**

Electrical surge strength requirement of high voltage coils is determined typically by the impulse voltages, especially lightning surges, to which they may be subjected. Westinghouse uses four principal types of windings:

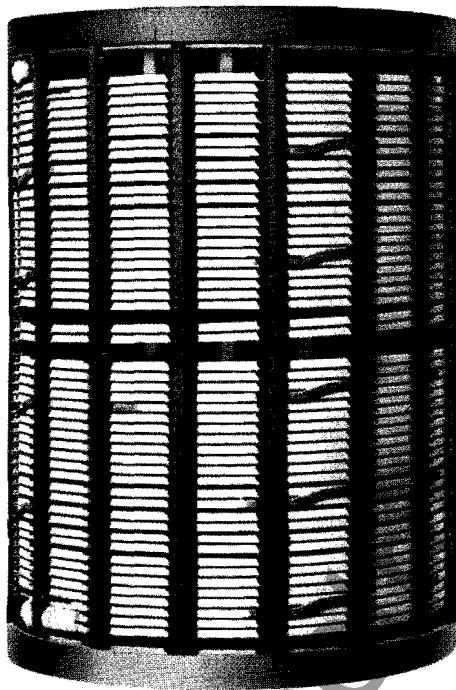

**Helitran Coil**

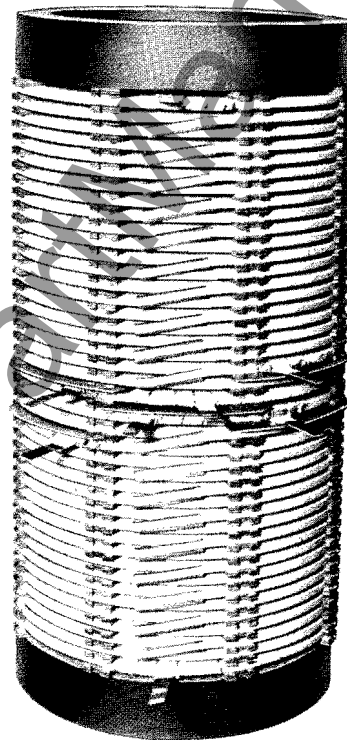

**Continuous Coil**

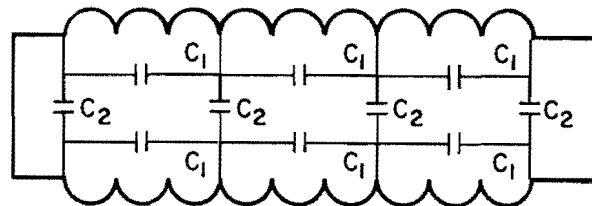
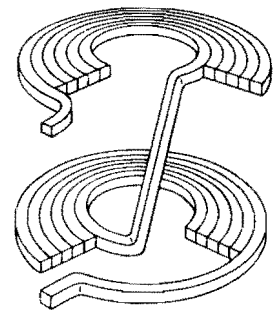

**Continuous Coil Schematic**

• Helitran windings. Helical with horizontal oil ducts between turns Helitran low voltage windings are most often used in Westinghouse transformers because of their simplicity, current carrying capacity, and high strength. A basic design, Helitran windings have proven their ruggedness and long life in the field. They have inherently good surge distribution characteristics within their range of application.

• Continuous disc windings. Coils wound with continuous disc windings are used at the lower BIL levels. These are simple, compact, uniform, and require minimum clearances. They have a predictable surge voltage distribution and lack shielding complications.

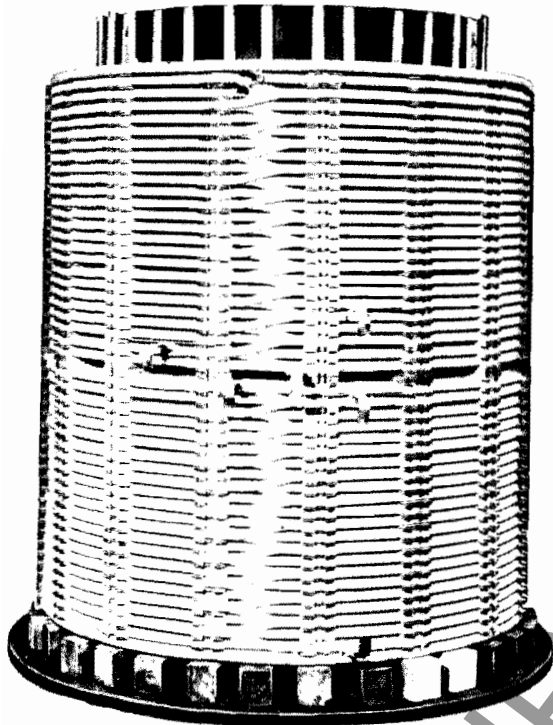

Hisercap Coil



Cylindrical Coil

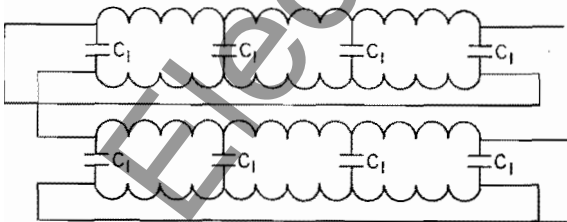
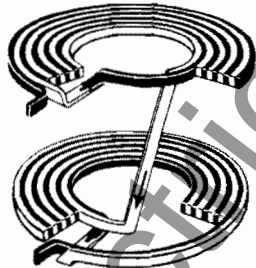

Hisercap Coil Schematic

• Hisercap windings. At higher BIL ratings, a variety of patented types of interleaved windings are used. One example is wound with two conductors in parallel and reconnected in series, greatly increasing the coils' series capacitance. "Hisercap" refers to high series capacitance, which improves the distribution of surge voltages. Final voltage distribution is uniform, transient oscillations are small, and insulation clearance requirements are reduced even at the highest BIL. Since less compressible material is required, the short circuit strength of Hisercap windings is high.

Cylindrical windings. For transformers up to 10 MVA, cylindrical windings are common through 95 KV BIL; they consist of one or more layers of insulated conductors wound on a strong Micarta winding tube with pressboard layer insulation and vertical cooling ducts. Coils are wrapped with thermo-setting polyester glass tape which hardens during baking to bind the coil. Two layer cylindrical tapping windings are used frequently in load tap changing (LTC) transformers.

$C_g$  = Ground Capacitance     $C_s$  = Series Capacitance

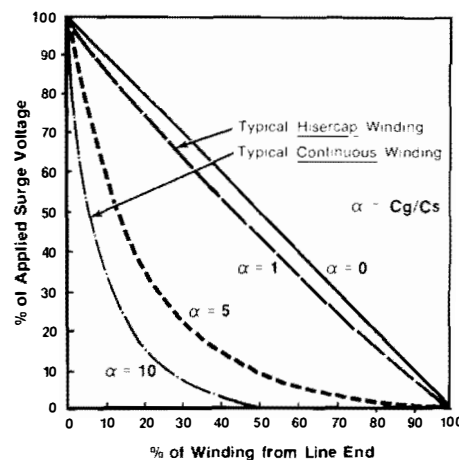

Surge Voltage  
Distribution  
Across Winding

**Thermal Capacity**

**Insuldur Capability**

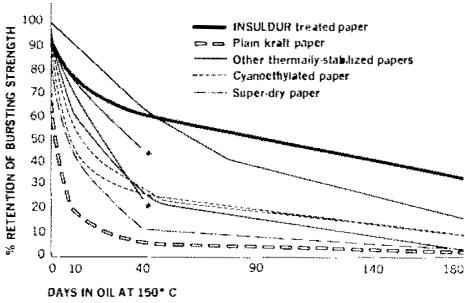

Overheating weakens untreated cellulose fibers, leading to accelerated aging and, in turn, shrinking and brittleness. Insuldur stabilizes insulation and retards deterioration of Kraft paper under operating temperatures. In accelerated tests simulating normal transformer operation, Kraft paper treated with Insuldur had 2.5 times the dimensional stability and 10 times the mechanical strength of untreated Kraft paper.

The Insuldur System of insulation creates a substantial increase in load and overload capabilities over other materials; maintains thermal and mechanical integrity under short circuit and overload conditions; and allows operations at 112% of name-plate continuously at 65°C rise with normal life expectancy.

**Transformer Overloads**

The ANSI and NEMA "Power Transformer Loading Guides" provide a method to estimate winding insulation loss of life under emergency overload conditions. Other factors such as oil expansion, tank pressure, stray loss heating, bushing leads, leads overheating, tap changer contacts overheating, and the thermal limits of auxiliary equipment can be critical. Specific transformer design should be checked with Westinghouse' Medium Power Transformer Department when planning overloads.

**Transformer Cooling**

The best of several methods to cool transformers is determined by balancing factors such as: first cost, cost of power, load cycle, noise and future requirements. Five typical systems used on Westinghouse transformers are:

OA self cooled. OA is common on transformers with lower KVA ratings; where the cost of power dissipated is highest; and where load cycle peaks are moderate and load is fairly constant. Transformers with OA cooling can be equipped for future fans to accommodate load growth.

Ratings are usually specified at 55°C rise continuous at rated load in an average

30°C, maximum 40°C (for any 24 hour period) ambient temperature. Insuldur insulation increases KVA ratings by 12% at 65°C rise continuous, or rated capacity may be specified at 65°C rise.

OA/FA self cooled, forced air cooled (also OA/FA/FA). Oil circulation through the coolers and coils is identical to OA cooling. The rate of heat transfer to outside

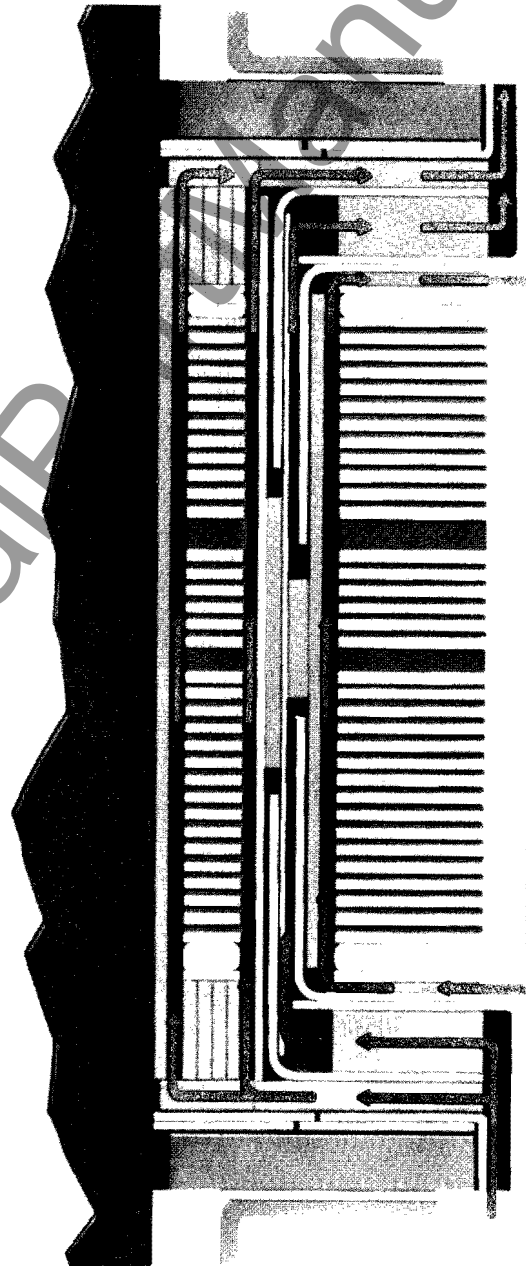

OA: OA/FA



air is increased in OA/FA cooling by forcing air over the surface of the coolers.

For some designs using Tubular Coolers, Fans are mounted on top of the coolers blowing air downward to provide maximum flow over areas of highest temperature.

Fans for transformers equipped with removable radiators are mounted on the

side of the radiators to force a high volume of air through ducts formed by the rows of fins.

Blower Specifications: Standard fan motors are  $\frac{1}{6}$  hp operating from a 230 V. single phase power supply. Three phase motors are also available. Fan blades are designed for high delivery and quiet operation.

➤ OA/FA/FOA or OA/FOA/FOA self cooled/forced air/forced oil cooled. Fans and radiators are identical to those used on OA/FA transformers; the return flow from the radiators is, however, collected in two or more headers at the bottom of the transformer tank, then fed into oil pumps which force the oil into a baffled area beneath the coil assemblies and rapidly up through the coils. The oil is directed by barriers and flows through the windings in a zig zag pattern to efficiently cool the coils' horizontal surfaces.

1. Pumps: The pump motors supplied are two or six hp depending on oil flow, and require 230 V. single phase power. Three phase 230 V. and 440 V. motors are optional. Motors and impellers are totally enclosed and oil immersed, sealed into the oil circuit. Motors are cooled by the circulating transformer oil.

• FOA—Forced oil/Forced air cooled. The FOA transformer has no load carrying capability when fans and pumps are not operating. The external heat exchanger in the FOA cooler is a bundle of finned tubes through which oil is forced. The finned tubes are enclosed in a housing containing a fan which directs air through them. Fan and pump motors are 230 V. single phase unless otherwise specified. Oil flow inside the tank and through the coils is identical for OA/FOA/FOA or FOA cooling. FOA coolers may be single cell (Type A) with one fan or three cell (Type B) with three fans.

FOA transformers are rated at maximum KVA at 55°C or 65°C rise. Units rated at 55°C will carry an additional 12% load at 65°C rise.

• FOW—Forced oil/Forced water cooling. In application, arrangement and its use of oil pumps, FOW cooling differs from FOA in that it requires a clean source of water under suitable pressure, and an oil to water heat exchanger to replace the FOA's oil to air unit. Flow of oil through the windings and use of pumps to move the oil is similar to FOA.

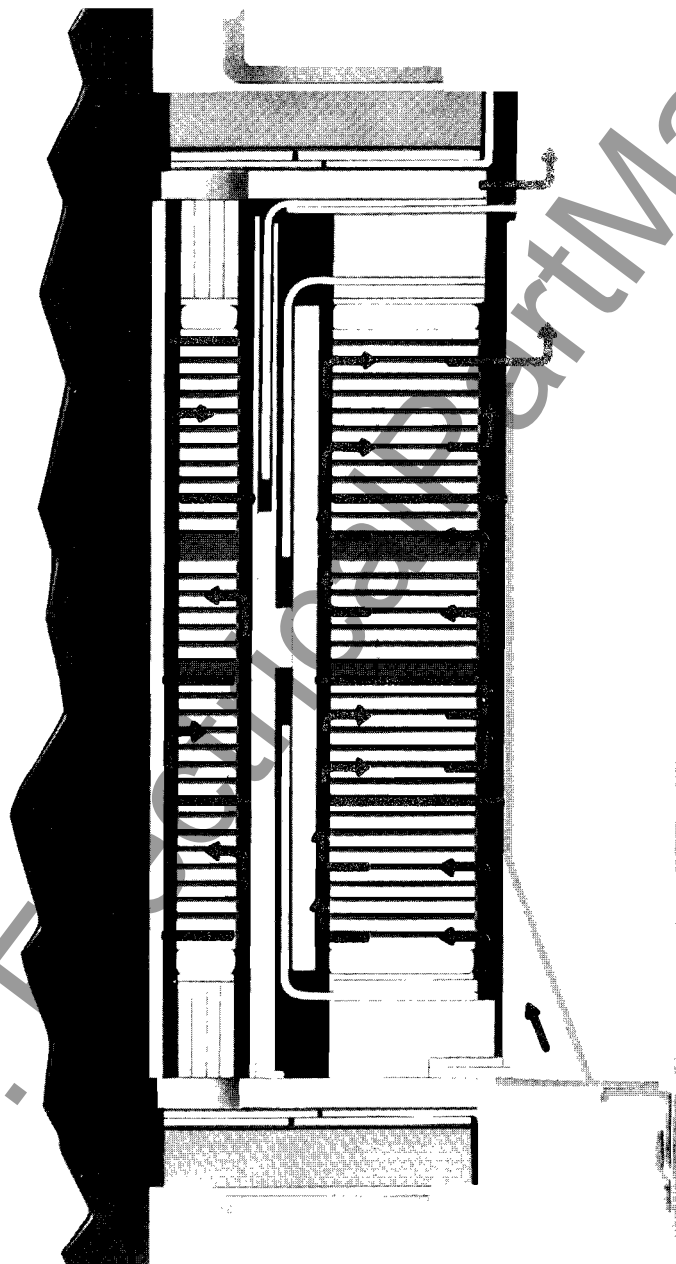

OA/FOA/FOA: FOA

WWW

**Load Tap Changing**

**Automatic (Energized) Load Tap Changing**  
 By adding or subtracting voltage on a three phase circuit, UTS, UTT and Vacutap load tap changers correct for varying source voltage or compensate for line drop as loads change. The standard regulation range of Westinghouse transformers equipped with load tap changers is  $\pm 10\%$  of rated voltage in  $32-\frac{5}{8}\%$  steps;  $1\frac{1}{4}\%$  operating steps are optional.

To change voltage taps under load, Westinghouse utilizes automatic load tap changers operating under the reactor switching principle to maintain load continuity during the transitions between positions. Tap changers are located in separate compartments to eliminate mixing of tap changer oil with that in the main tank. Tap changers can be maintained without entering the main tank.

Standard load tap changers can be categorized as those with arcing contacts in oil —types UTS and UTT; and those with vacuum interrupters—type UVT and UVW (Vacutap).

- Advantages of UTS, UTT and Vacutap load tap changers are:

1. Current carrying contacts are accurately

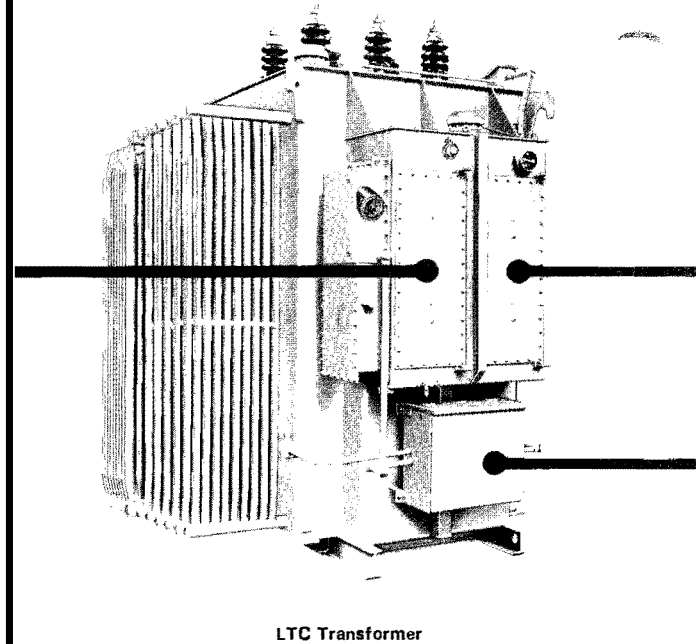
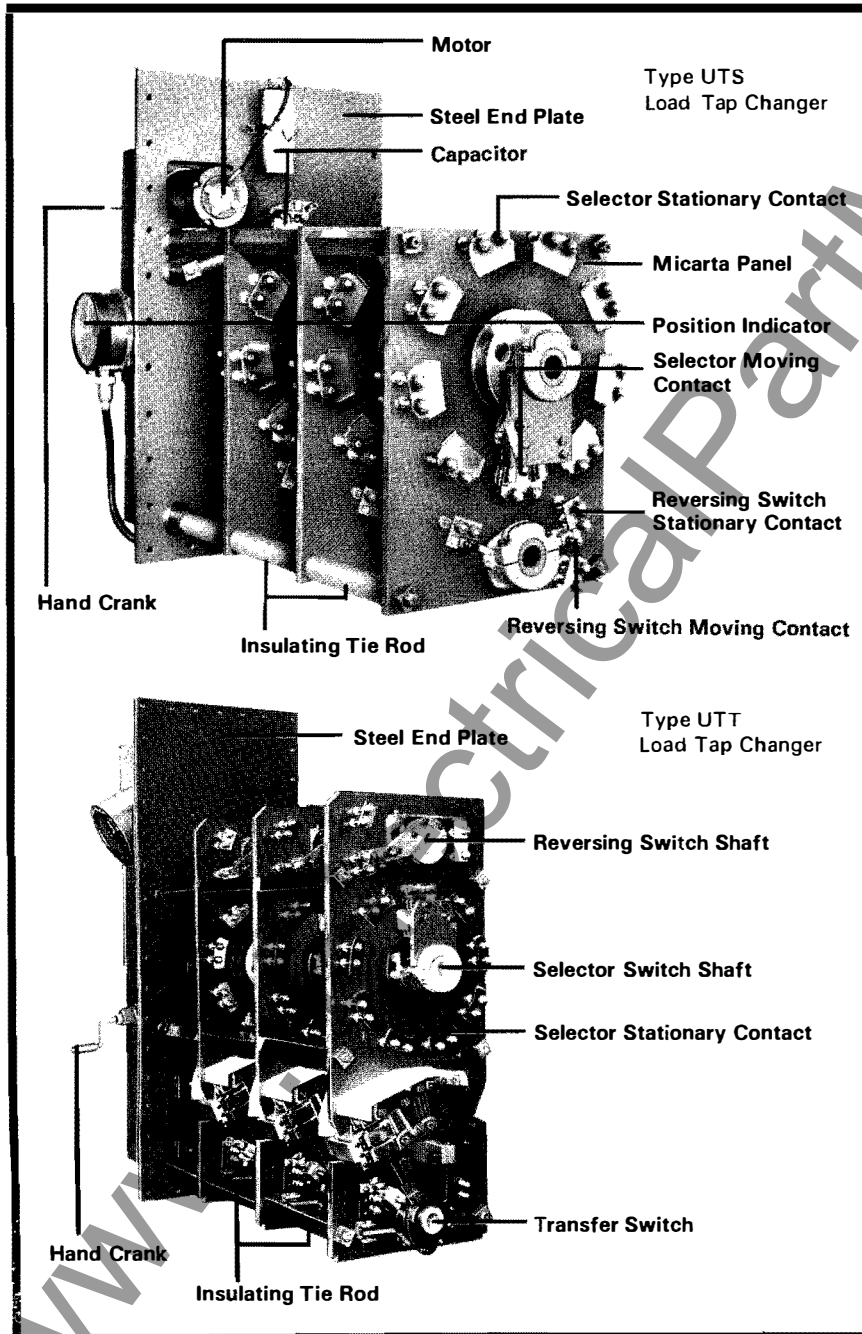

LTC Transformer



centered and locked on position by Geneva gears.

2 Total safety provided by control limit switches with electrical back up switches and mechanical stops.

3 Reduced maintenance and inspection time with unit construction and easy access to all parts.

4. Long life Elkonite contacts on UTS and UTT tap changers; UVT and UVW tap changers are warranted for 500,000 tap changes without exceeding the interrupter life.

UTS and UTT tap changers emphasize savings through a compact, unitized, drawout design, providing ease of maintenance and interchangeability. UTS load break con-

tacts of copper-tungsten carry a 20 year pro-rated warranty and UTT contacts are warranted for 150,000 operations on a pro-rated basis.

• UTS tap changers. Each UTS tap changer is assembled as a complete unit which can be installed or removed as one component. Each UTS tap changer consists of:

1. The drive mechanism, housed in one compartment, is under oil. It comprises a motor, reduction gear and main spring power mechanism. The position indicator and hand crank are on the case.

2. The selector and reversing switch assemblies are in a separate compartment which shares a common source of oil with the mechanism. The three selector and reversing switch assemblies—one per phase—are assembled on insulating rods and supported from the mechanism side plate. Each selector switch includes stationary contacts, two moving contacts, and two sliding contacts which carry current to the moving contacts. A common shaft from the operating mechanism drives all three selector switches. A separate shaft located below the selector shaft drives the reversing switch to reverse connections at the appropriate point in the switching sequence.

3. When a cam switch assembly is required for special control functions, it is housed in an air compartment located below the drive mechanism.

• UTT Tap Changers. The UTT tap changer is larger but similar in design to the UTS tap changer. It is applied on higher loads where arc interrupting duty on selector switches would be excessive. Transfer switches in series with the selector switches are provided to handle the circuit opening duty. The selector switch assemblies are arranged in the same manner as in the UTS. Each selector phase assembly has two transfer switches located at the bottom of the panel which are driven by a third shaft. A more powerful operating mechanism is provided than in the UTS because of greater mechanical load.

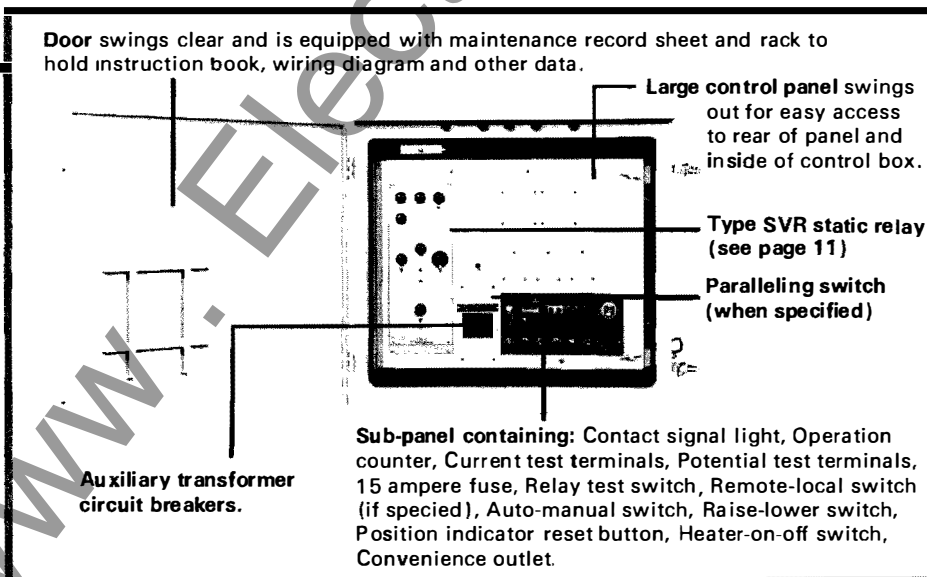
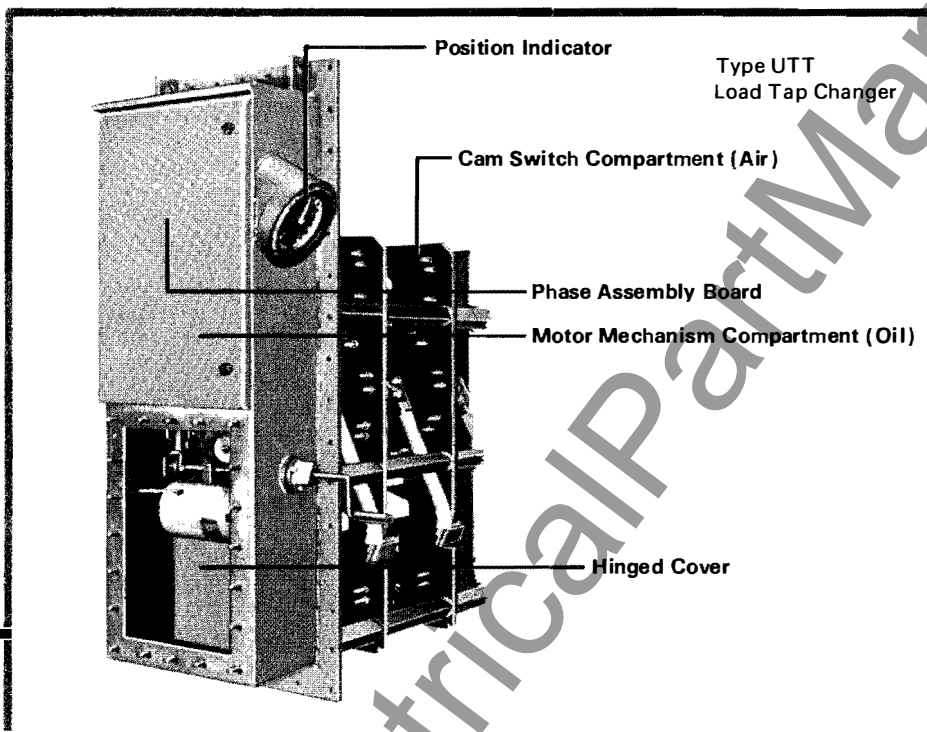

**Load Tap Changing cont'd.**

• Vacutap Load Tap Changers. Type UVT and type UVW load tap changers employ vacuum interrupters in the transfer switches to open the circuit to the selector switch, permitting the selector to operate with no current interrupting duty. The vacuum interrupters are warranted for 500,000 operations of the tap changer. The long life of the vacuum bottles and elimination of arcing under oil give added reliability with very low maintenance requirements.

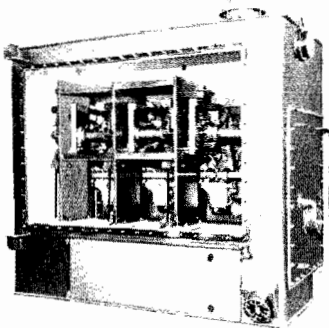

1. UVT Tap Changers. The UVT is a high voltage, high current tap changer with a tap changing cycle of approximately one second. It was developed for industrial applications requiring high speed operation and low maintenance and for the higher voltage and current needs of the larger core from transformers. The UVT is built with extra mechanical endurance to handle the more frequent operations encountered in industrial applications.

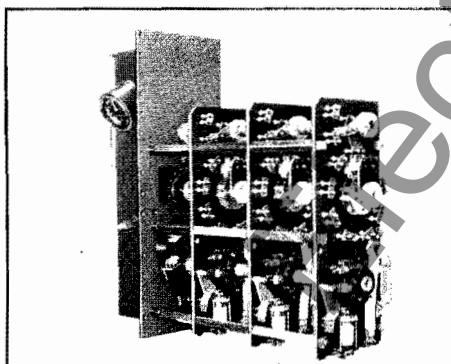

2. UVW Tap Changers. The UVW brings the advantages of the vacuum interrupter to medium voltage and current range applications which do not require the high speed of the UVT. Tap change time is approximately 1.5 seconds. The vacuum interrupters are warranted for 500,000 total operations of the tap changer. Low maintenance results from long interrupter life and interrupting of the circuit in a vacuum rather than in oil.

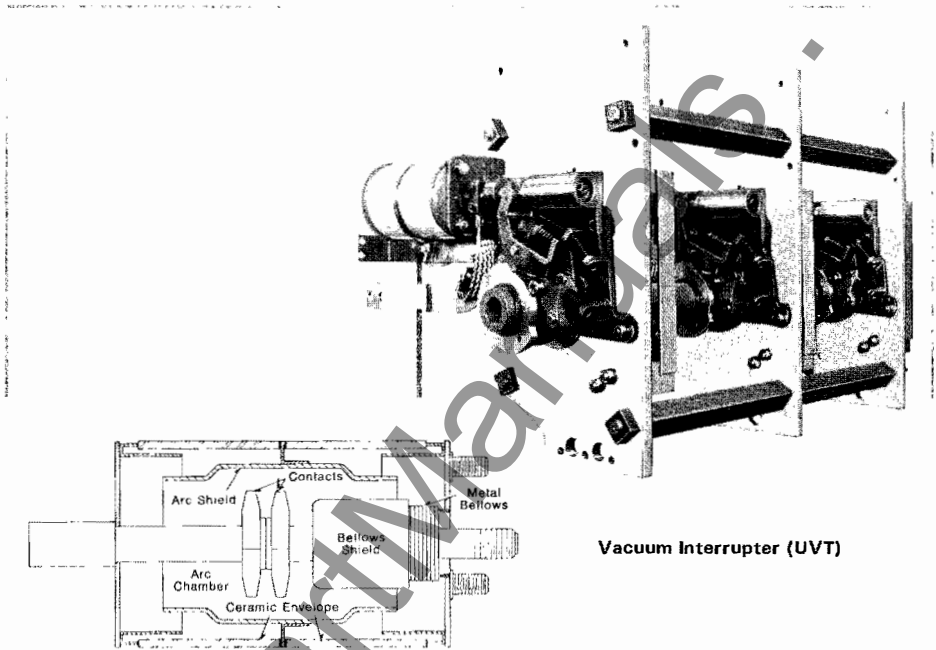

**Vacuum Interrupter (UVT)**

**Vacuum Interrupter (UVT)**

The vacuum interrupter assembly for each phase is mounted on a Micarta® board and the phases are positioned by means of insulating spacer rods. One drive shaft operates all phases simultaneously.

The vacuum interrupter drive assembly is a cam action spring drive mechanism. To open the interrupter, the spring driven mechanism impacts an operating rod connected to the moving contact of the interrupter. The velocity imparted to the moving contact is controlled through an oil dashpot. The interrupter is locked in the full open position while the selector switch changes taps. Upon completion of tap selection the interrupter mechanism is unlocked and the

moving contact is closed by the pressure differential between the vacuum in the bottle and oil pressure in the compartment acting on the bellows seal connected to the contact shaft. Closing speed is also dashpot controlled.

The vacuum interrupter consists of a stationary and moving contact enclosed in a vacuum tight bottle. The moving contact rod is sealed through a flexible metal bellows protected from the arc by a shield. A metal envelope surrounds the contacts forming an arc chamber and condensing surface to collect vaporized contact material. The ceramic insulating envelope is connected to the metal part by vacuum tight seals.

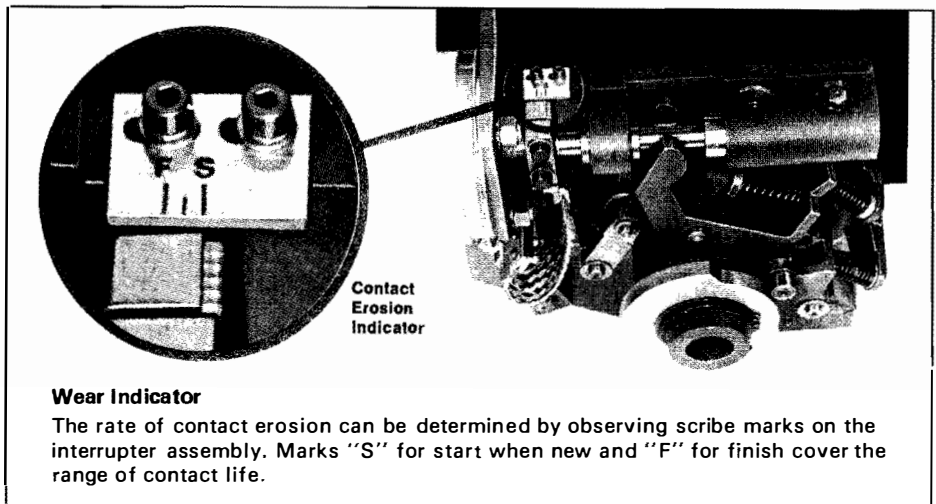

**Wear Indicator**

The rate of contact erosion can be determined by observing scribe marks on the interrupter assembly. Marks "S" for start when new and "F" for finish cover the range of contact life.

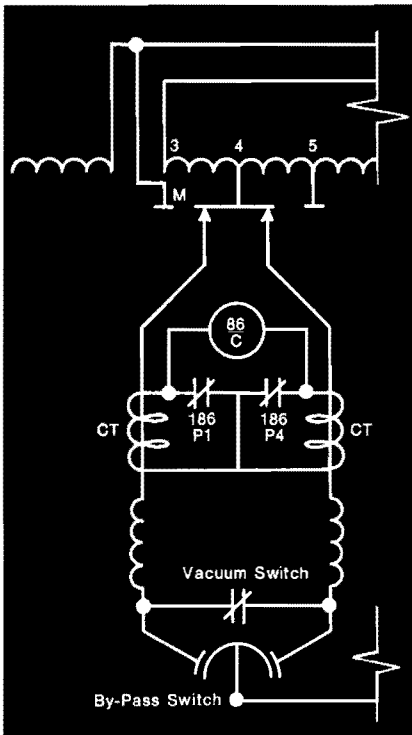

UVT Schematic Diagram

3. C. T. Monitoring Circuit. The circuit interrupter in the transfer switches of UVT and UVW tap changers is a vacuum bottle. It is actuated by a cam and spring mechanism to open the circuit to the selector switch moving contact just prior to a tap change. To guard against vacuum bottle failure, a monitoring circuit measures current in the selector moving contact lead. If current is present in the selector lead, after the interrupter should have opened the circuit, the control circuit is locked out to prevent further tap changes. In the UVT tap changer, the tap change is completed to the next position because of the operating speed. In the UVW, the tap change is arrested and the moving selector contact is returned to its last previous position.

• Voltage Regulating Relay. The Westinghouse SVR Voltage Regulating Relay is a comprehensive, static control package mounted on a single chassis for ease of replacement. The relay is an ANSI standard class 1 accuracy device. It requires no warm up prior to making settings. Continuous adjustment controls are secured by locking devices. All other controls are snap switches which cannot be inadvertently reset.

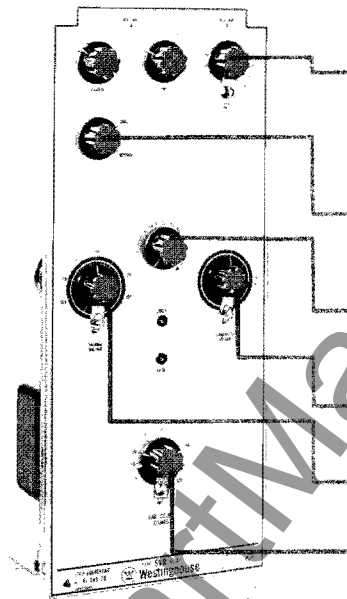

Voltage Regulating Relay

Calibrated control knobs are provided on the front of the relay for:

Line drop compensator. Reactance compensation is adjustable in one volt steps from 0 to 24 volts. Reactance compensation is continuously adjustable from 0 to 24 volts.

Reactance reversal. Snap action control, permits parallel operation of regulating transformers by reverse reactance method.

Test rheostat. The continuously variable test rheostat varies voltage to the relay for adjustment and testing.

Bandwidth. Bandwidth is continuously adjustable from 1 to 6 volts.

Balance voltage. Settings are continuously adjustable from 105 to 135 volts.

Time delay. The time delay control knob provides settings which are continuously adjustable from 2 to 120 seconds.

### Manual (de-energized) Tap Changers

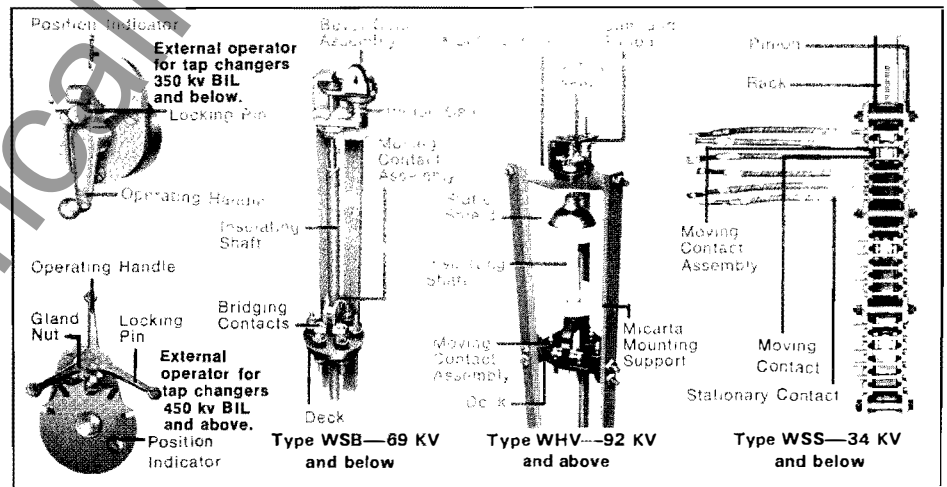

Type WSS, WSB and WHV tap changers are three phase unitized assemblies which are mounted on the core and coil assembly and cabled to the coil taps. Type WCA tap changers are individual phase assemblies which are mounted vertically, adjacent and perpendicular to the coil taps, and linked with a common operating mechanism. Tap leads are short and tank size is reduced. Other features include:

• Self cleaning contacts. All de-energized tap changers have self cleaning, self aligning, positive positioning, silver plated or elector tin plated copper contacts.

• Positive contact. Two parallel moving contacts provide firm positive pressure to assure good contact with stationary contacts.

• Accurate positioning. A Geneva gear-cam assembly controls the moving contacts and assures accurate positioning and locking when taps are changed.

• Operating ease. The operating handle and position indicator are located on the tank wall at a convenient operating height. Provision is made for padlocking the operating handle.

### Bushings

Westinghouse experience and leadership in developing and building bushings, in combination with an excellent service record, provide assurance of their high reliability and low maintenance. The mechanical and electrical characteristics of Westinghouse bushings conform to ANSI Standard C 76.1. Interchangeable bushings rated 23 through 196 KV can be used on transformers on circuit breakers, reducing investment in spares.

#### Bulk Type Bushings

\* Porcelain bulk type bushings consist of a conductor surrounded by a rigid insulator used to isolate the conductor electrically but anchor it mechanically. They are gen-

erally used at 15 KV or below, but are also available at 25 KV. In the RJ bushing, the insulator is a wet process porcelain with a metal flange affixed by rolling a sleeved portion of the flange into a groove on the porcelain, with a silicone gasket between the sleeve and porcelain. Mechanical stress on the porcelain is eliminated. A conducting lead is inserted in the porcelain and the assembly is sealed by gaskets.

- Cast resin bulk type bushings in their simplest form consist of a conducting stud cast into a resin body. The resin body may have a cast flange of resin for bolting in place, a cast in metal ring for welded on applications, or a cast in metal flange for bolted on applications. Cast resin bushings with multiple bar conductors in a single

block provide a single unit for 3 phase connections and reduce the number of tank openings. Multiple conductor resin bushings are also used for special high current applications.

#### Condenser Bushings

- Condenser type bushings are generally used above 15 KV. The application of the condenser principle was developed and patented by Westinghouse. Concentric metal foil layers of proper dimension are spaced outward from the conducting stud, interposed in the insulation. This creates the effect of a string of capacitors in series, across which voltage divides evenly between the stud and the flange. The insulation is evenly stressed dielectrically. The effective utilization of high strength insulation makes it possible to reduce the size of

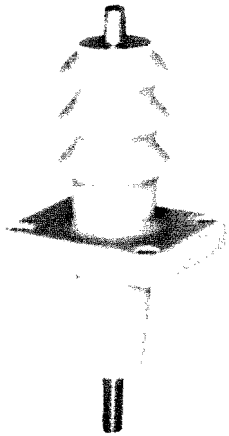

Cast Resin

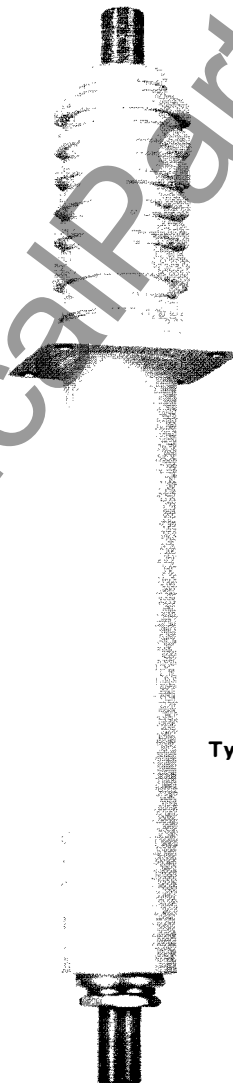

Type "RJ"



Type "O-AL"

WWW.ElectricalPartMAGAZINE.COM



the bushing while maintaining full dielectric strength. Condenser bushings are designated types OS, O, O-AL, and RCP.

**Type OS Bushings.** The OS bushing condenser is resin bonded, made by winding specially treated Kraft paper over a central tube or stud with metal foil wound in at specified diameters. The upper portion is assembled into a porcelain weather casing filled with oil and the bottom is protected by a coating of high grade insulating varnish. Type OS bushings are used from 23 through 69 KV.

**Type O Bushings.** Used above 46 KV, type O bushings have oil impregnated Kraft paper condensers completely encased in a chamber consisting of upper and lower porcelain, and which are filled with oil.

An expansion bowl at the top of the bushing allows the oil to expand. A mounting flange is located at the middle of the bushing with gaskets between it and upper and lower porcelains. Gaskets at top and bottom of the bushings seal the oil chamber and a unique spring arrangement at the top clamps and seals the entire assembly against the bottom support, yet allows movement of the stud due to dimensional changes with temperature. An oil level indicator is provided and the mounting flange is provided with a voltage tap receptacle on units rated over 115 KV.

**Type O-AL Bushings.** An aluminum conductor with a patented duct system is used in the type O-AL bushing. The duct reduces heat accumulation and improves thermal performance. O-AL bushings are lighter and

stronger than type O bushings. All-welded construction requires gaskets only at the ends of the porcelain. Otherwise, they have the characteristics of type O bushings.

**Type RCP Bushings.** The RCP bushing is a cast resin condenser bushing. The condenser foils are encapsulated in a common resin body with the conducting stud. An integral cast resin flange is used for mounting. The upper portion is enclosed in a porcelain weather casing and the space between the condenser and casing is filled with elastomeric material having good dielectric strength and moisture properties. The bushing can be mounted in any position since it has no oil. The RCP bushings are primarily transformer bushings and are not interchangeable with circuit breaker bushings.

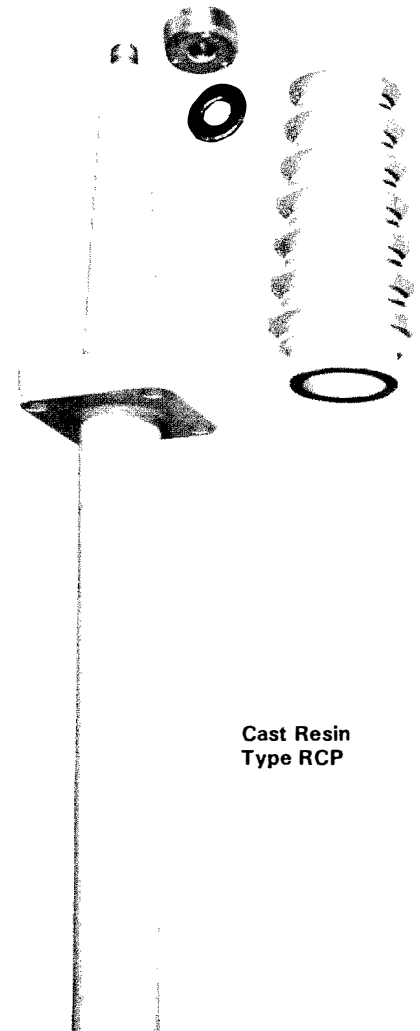
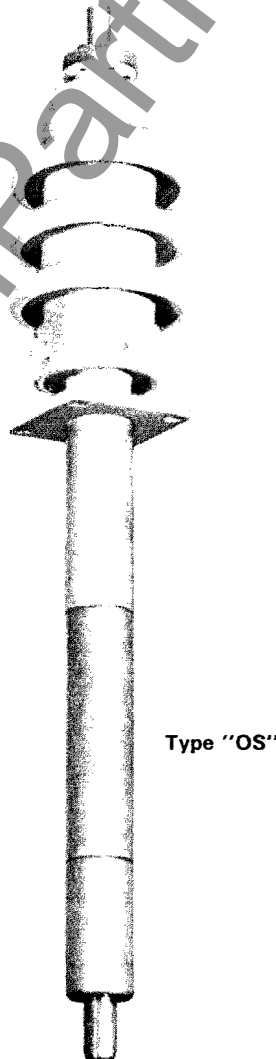

### Transformer Protection and Fault Detection

Devices for internal and external monitoring minimize the effects of transformer and system faults. The devices can be installed on the transformer in the shop, or provided separately for field installation.

#### Internal Monitors

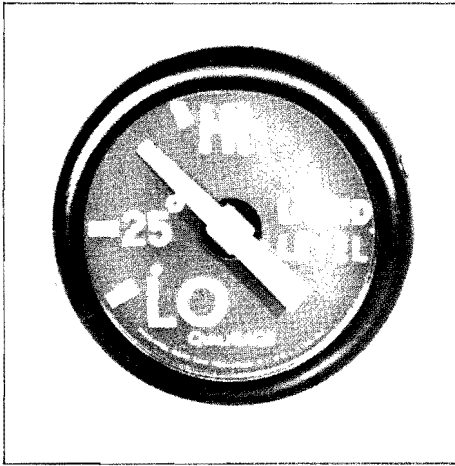

- Magnetic liquid level gauges. Determined by float position oil level is transmitted magnetically through the tank wall to the indicating dial and bezel, preserving the tank's seal. Alarm contacts are optional.

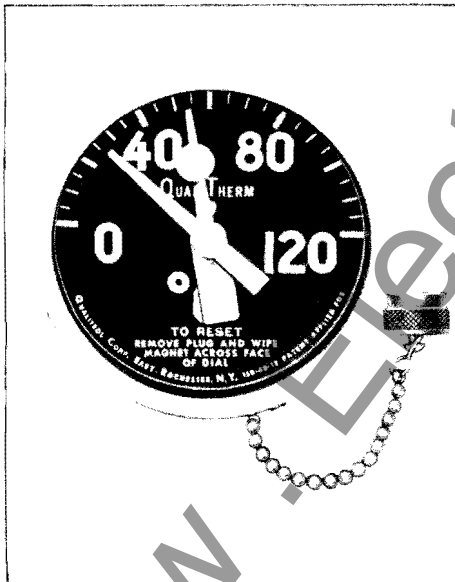

- Dial type liquid thermometer Mounted in a well on the tank wall, the liquid thermometer indicates the temperature of the top liquid. A magnetically resettable red pointer indicates peak temperature. Alarm contacts are optional.

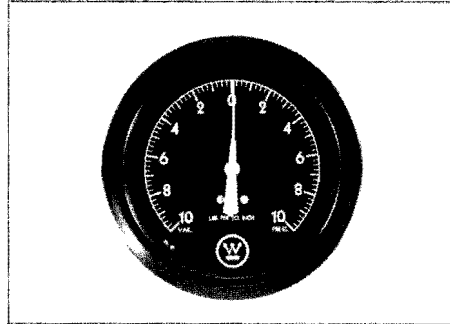

- Pressure vacuum gauge. This gauge indicates the pressure of the gas inside the tank gas space.

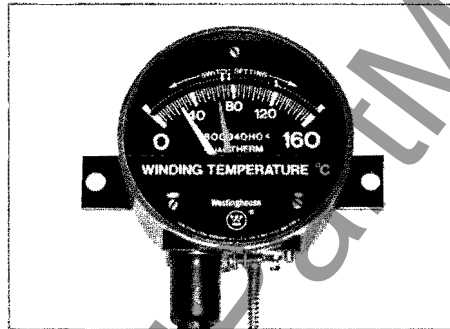

- Winding temperature indicators. Simulated hot spot temperature, indicated by this device, is used to control the auxiliary cooling equipment on triple rated transformers. Switch settings are indicated on the dial face and may be easily adjusted.

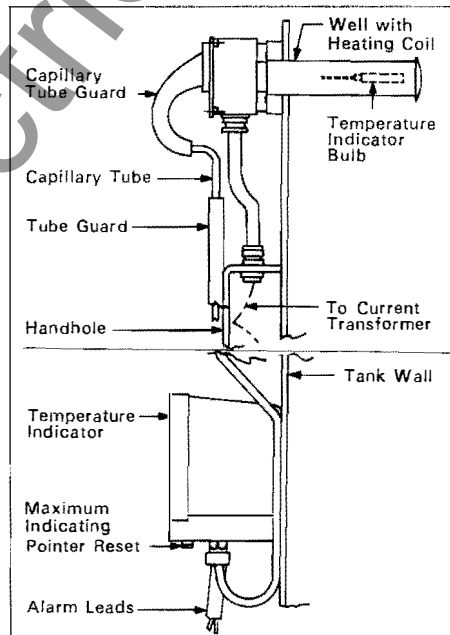

Sectional View of Transformer Showing Mounting of Winding Indicator with Flexible Tube

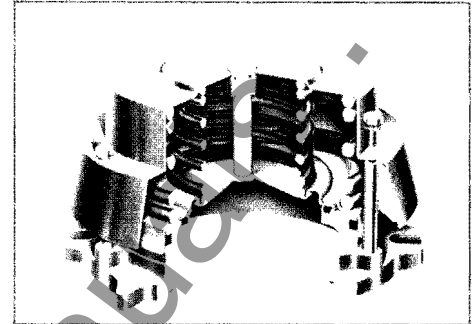

- Mechanical Relief Device. Excessive internal pressures are mechanically relieved by this device which is factory calibrated to operate at 10 psi. After operation, the device reseals automatically.

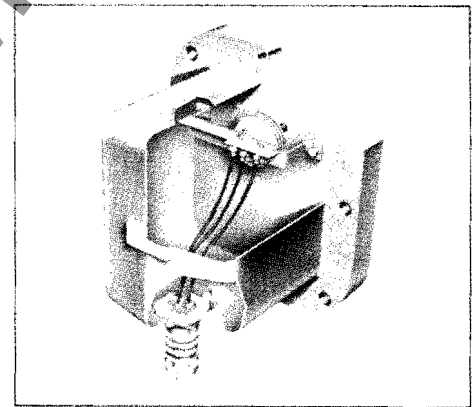

- Sudden Pressure Relay. Detection of internal faults is provided by this device which responds to rapid increases in internal pressure caused by arcing. The relay operates more rapidly as the pressure changes more rapidly. It will not respond to the normal pressure changes due to fluctuations in transformer temperature or loading, system short circuits, magnetizing inrush currents, seismic forces or impulse voltages. It will respond to small arcs which would not affect a relief device. If pressure rises rapidly it will operate within 1/2 cycle on a 60 cycle circuit.

#### External Monitors

- Differential relays
- Overcurrent relays
- Ground fault relays
- Primary fuses
- Lightning arresters
- Linebacker switches
- Breakers and reclosers



### Standard Features

#### WEMCO "C" Insulating Oil

In order to have an insulating oil which would complement its Insuldur insulating system, Westinghouse provided the characteristics and encouraged oil companies to develop and make available to all industry WEMCO C, an oil with a flash point of 283°F. Subsequently the flash point has been increased to 293°F, 20°F higher than oils used previously. In addition to increasing the margin of safety, the new oil has characteristics which equal or better other desirable characteristics of previous oil, such as lower pour point.

#### Finish

All surfaces of Westinghouse transformers are:

- Grit blasted to clean, textured metal for ideal paint adhesion.
- Primed with one, 1-mil rust inhibiting coat of an alkyd type vehicle with zinc chromate and iron oxide pigments.
- Top coated with two, 1-mil coats of an alkyd type vehicle with special pigment selected for good appearances and long outdoor protection in varying climates. Color is ANSI standard sky grey No. 70 (Munsell No. 5.0 BG 7.0/0.4)

#### Control Wire Insulation

Control wire insulation is a special Westinghouse PVC and is in accordance with IPCEA S-61-402 105°C appliance rating; its proven practical thermal rating is above the 75°C National Electrical Code (NEC) rating for THW wire. The wire is approved by the NEC for use in wet or dry locations, has an excellent service record, and is conservatively used in conformance with the NEC 75°C rules.

### Sealedaire Oil Preservation System

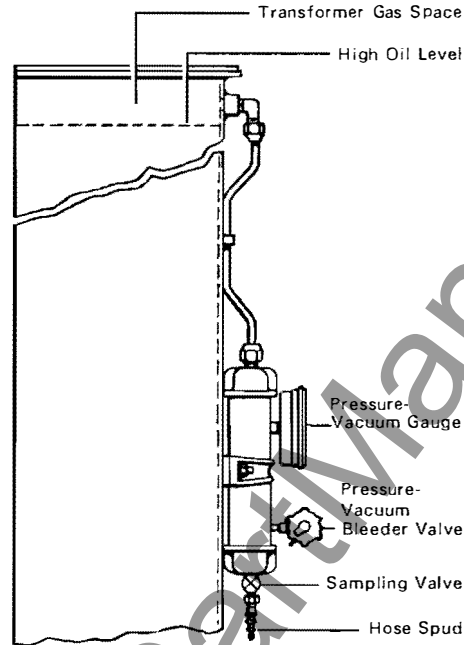

The Westinghouse Sealedaire System excludes oxygen and moisture from the transformer tank to protect the transformer oil and insulation. The transformer tank remains sealed throughout an oil temperature range of 100°C. Pressure and vacuum-limiting valves open at  $\pm 6.5$  psi to relieve

excessive pressure. Provision is made for gas sampling or purging.

#### Coolers

Finned type coolers, and radiators either of all welded sheet metal or tubular construction are provided on large transformers which require removal of cooling to meet shipping dimensions. Valves at top and bottom are welded to the tank, and coolers are sealed to the valves with gaskets and bolted in place.

- **Fan Assembly.** Each fan assembly for forced air cooling consists of a fractional horsepower motor and glass reinforced polyester fan blade mounted on a steel wire-formed bracket and blade guard. The motor is capacitor-start, capacitor-run, with a stainless steel shaft and automatic reset thermoguard. The motor's ball bearings minimize maintenance. The glass reinforced polyester fan blade was specially developed to resist corrosion from salt spray, chemicals and ultraviolet rays. It is designed for high delivery with low noise.

- **Pump Assembly.** Self-cooled/forced oil/forced air cooling systems combine oil pumps with fans. A pump assembly consists of a centrifugal pump and close-coupled squirrel cage induction motor enclosed in a cast iron housing, through which the transformer cooling oil flows to cool and lubricate the pump and motor. The pump assembly is equipped with sleeve bearings.

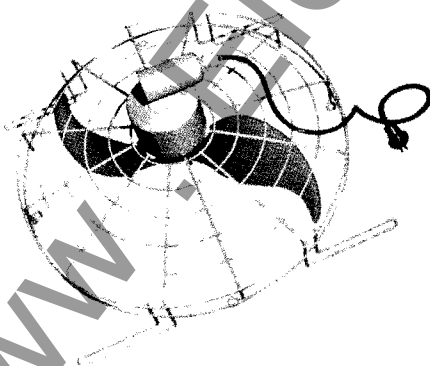

Fan Assembly

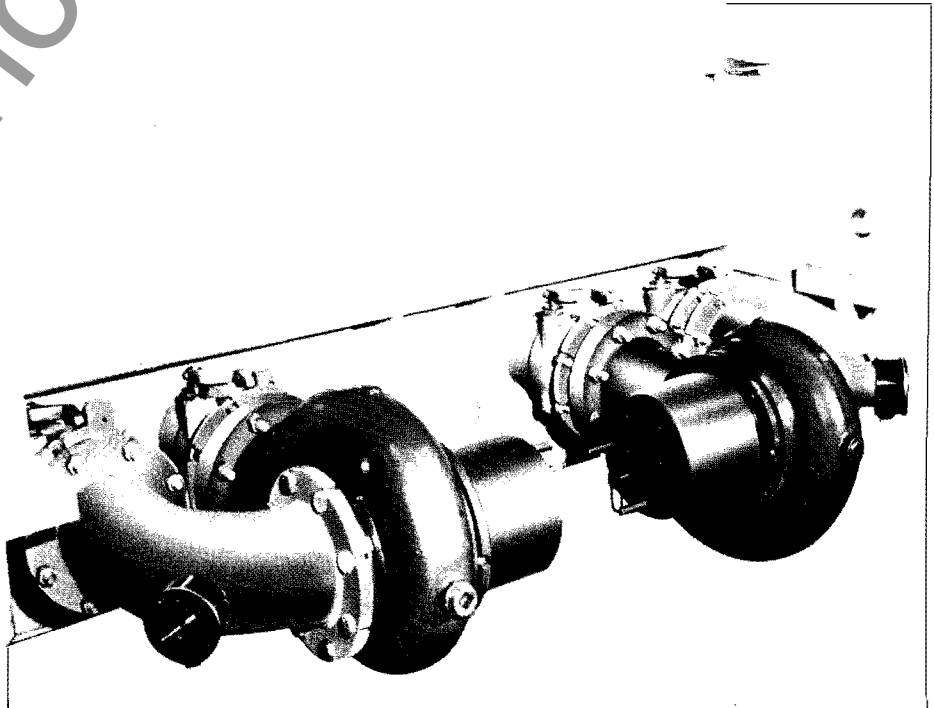

Pump Assembly

**Optional Features**

**Throat Connections**

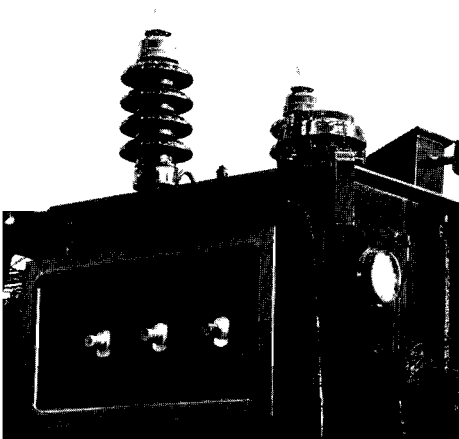

Flanged metal throats are available in segregated, non-segregated, and isolated phase designs for enclosing high or low voltage leads from transformers to switchgear, bus duct, or other equipment.

**Inertaire Systems**  
 Inertaire equipment protects the oil in the transformer from oxygen and moisture by providing dry nitrogen under light positive pressure in the gas space above the oil in the tank, regardless of the transformer's thermal cycling and outside temperature. Excessive pressure is relieved to atmosphere, and lost gas is replaced from a cylinder of dry nitrogen if pressure drops.

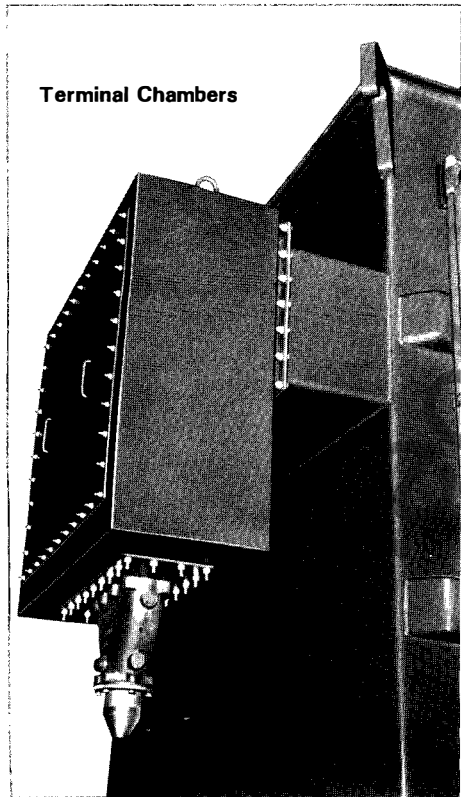

**Terminal Chambers**

High voltage and low voltage terminal chambers are available for cable entrance, with or without potheads for 69 kV and below. Air-insulated chambers are available for 34.5 kV and below. Oil chambers can be supplied for 69 kV and below.

**OSHA Fan Guards**

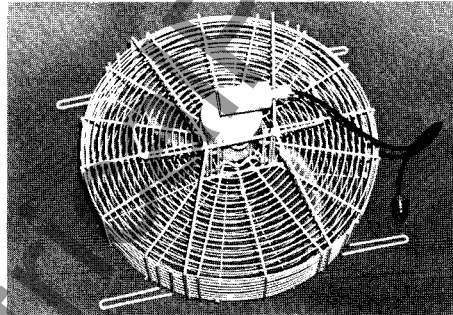

If fans are below 84 inches from ground level and OSHA guards are specified fan guards are supplied which have wires spaced to limit openings to less than 1/2 inch.

**Current Transformers**

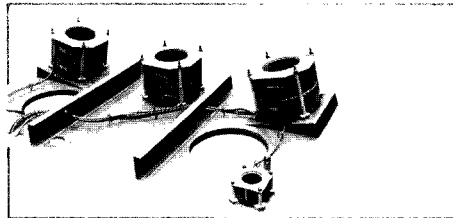

Bushing type current transformers can be supplied to provide current for protective relays and indicating instruments. They are supported by brackets under the tank cover and use the bushing lead as a single turn primary. External CT's can also be furnished.

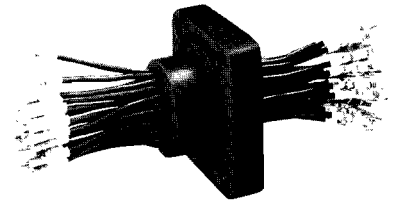

CT leads are brought outside the tank through a cast resin junction block. Each lead is bonded to its insulation and the required number of leads are encapsulated in the resin, forming a single leak proof assembly which is sealed to the tank with a gasket. Captive markers on each wire eliminate the need for ring-out before making connections.

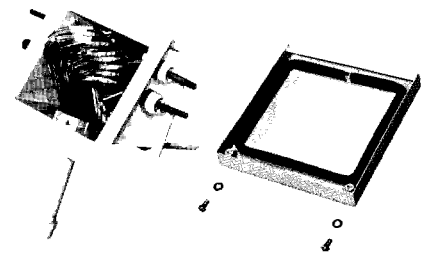

A junction box houses the CT leads external to the tank. The front of the junction box housing is slanted to increase working space, and a unique gasketed cover includes locking hardware. The housing has passed the ASTM waterproof test.



## Transporting Westinghouse Transformers

### Rail Transportation

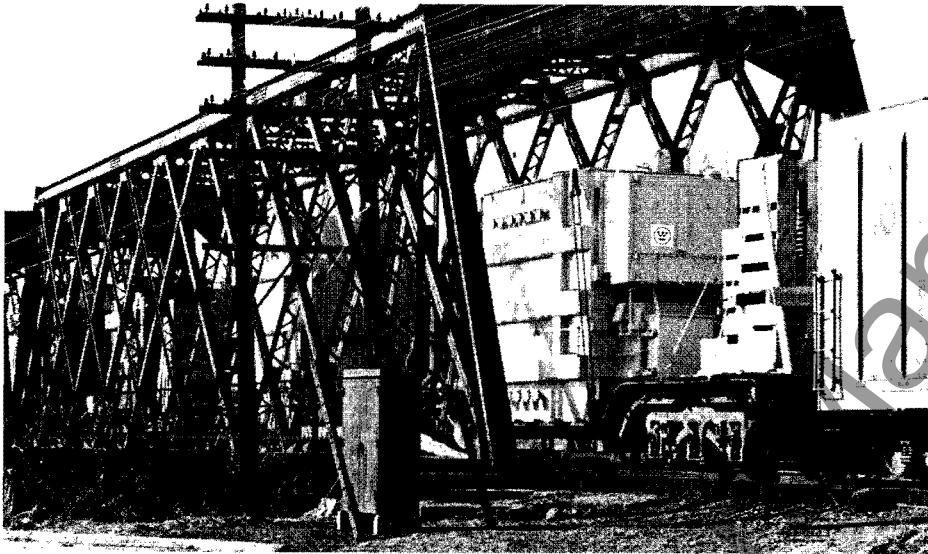

Rail Shipment Requires Clearance Information

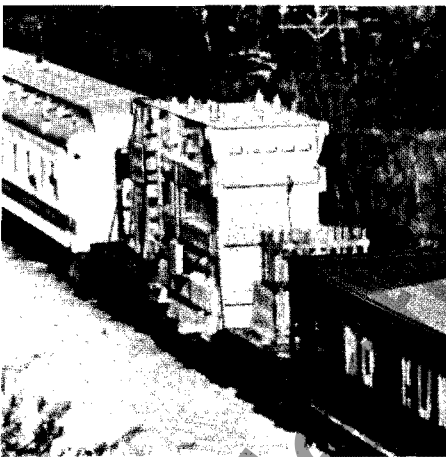

Unit Ready for Rail Shipment

### Rail Transportation

Westinghouse has worked with the railroads to improve their handling of transformers during shipment, and conducted extensive studies to determine the magnitude of stresses and shocks encountered during shipment. Improved Westinghouse designs have evolved from these studies. Typical improvements have been made in end frames, core punching supports, punching clamps, lead supports, bottom locating pins, tie plates and cooler supports.

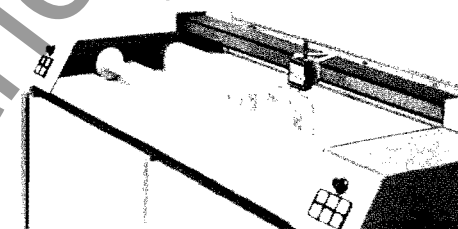

Computerized Plotter

### Computerized Shipping Dimensions

Specific destination, siding and delivering carrier are needed to design a transformer with assurance that it can be delivered where required, and to select the best type of rail car and the best route. A computerized profile plotter is used to define the shipping dimensions and weight of each transformer; auxiliary parts that must be removed for shipment; the best type of railroad car to be used; the route with the necessary clearances, smoothest ride and earliest delivery; and other restraints.

## Drawings and Instruction Books

### Approval Drawings

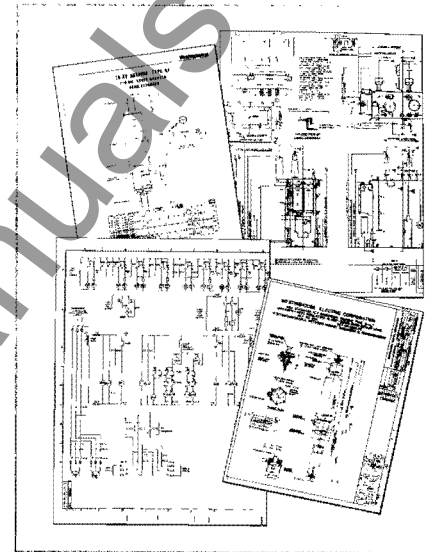

When drawing approval is required, Westinghouse will provide 5 sets of prints or one set of temporary transparencies (paper or polyester base).

### Final Drawings

Customer may elect to receive and Westinghouse will provide, in its standard format, one of the following:

- 8 sets of paper prints
- 1 set of paper transparencies
- 1 set of polyester base reproduceables
- 1 set of 35mm aperture cards
- 1 set of drawings on 35mm film strip

### Instruction Books

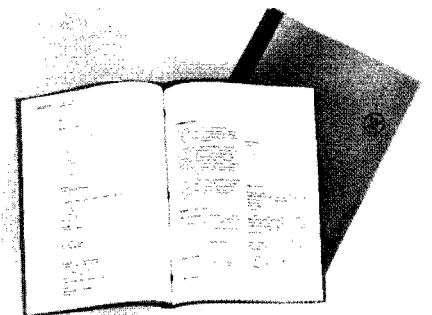

Westinghouse will provide 5 instruction books in standard Westinghouse binders for each item ordered. One of the books will be included in the transformer shipment.



### Westinghouse Firsts in Transformer Development

For over 90 years Westinghouse has met the growing needs of industries and utilities for transformers with increased reliability and safety, and lower maintenance and operating costs. This has been accomplished by constantly introducing new developments and improved designs.

- 1886 George Westinghouse granted first American transformer patent.
- 1890 First 3000-volt system and transformers.
- 1892 First 10,000-volt transformer. Water cooled transformer.
- 1897 First 40,000-volt transformer.
- 1906 Silicon Steel.
- 1907 Condenser bushings.
- 1912 Detachable radiators.
- 1913 First 150,000-volt transformer. Micarta insulating materials.
- 1917 First multi-winding transformer.
- 1921 220,000 volt power transformer with de-energized tap changer.
- 1923 First Inertia oil-preservation system. First hottest spot indicator.
- 1924 Developed high-frequency turn-to-turn insulation test.
- 1924 Load tap changers.
- 1928 Surge generator for power transformer testing.
- 1929 Sealed air oil protection for power transformers.
- 1931 Commercial impulse testing.

- 1932 Forced oil cooling (railway) Hipersil steel. Vacuum filling of transformers.
- 1940 Solder seal bushings.
- 1942 Type "O" oil filled condenser bushings.
- 1943 Form fit tank.
- 1946 500 KV Tidd transmission line transformers (experimental).
- 1948 First mechanical-trip, pressure-relief device.
- 1950 Coastal finish paint.
- 1951 Developed sudden-pressure relay. First commercial aluminum-wound power transformer.
- 1952 220,000 KVA power transformer.
- 1953 345,000 volt power transformer.
- 1954 400,000 KVA power transformer.
- 1956 World's largest sound testing laboratory; power transformer designed by computer.
- 1957 Schnabel railroad car.
- 1958 Insuldur insulation system.
- 1960 Resistance type tap changer for high voltage applications.
- 1961 750 KV Apple Grove transmission line transformer (experimental).
- 1962 Contract signed for 500 KV commercial system. 600,000 KVA transformer shipped.
- 1963 Order received for 725,000 KVA, 345 KV three phase transformer.
- 1964 First 500 KV transformer for commercial use shipped; new improved Insuldur.
- 1965 Laminated pressure rings. First 735 KV transformer for commercial use shipped.

- 1967 Order received for 1,000,000 KVA transformer.
- 1968 950 MVA 3 phase transformer shipped; first 765 KV transformer and reactor for commercial operation shipped.
- 1969 First 1100 KV transformer (experimental) shipped; 1,000,000 lb. capacity Schnabel car.
- 1970 First Transformer to pass IEEE short circuit test.
- 1970 Glass reinforced polyester fan blades. 1,000,000 KVA transformer shipped.
- 1971 Order received for 1,300,000 KVA, 345 KV three phase transformer. Pultruded polyester glass vertical spacers.
- 1972 High strength Micarta winding tubes. 150 KV BIL dry type Hisercap construction. Westinghouse announces 10 Year Warranty on Core and Coils of Shell Form Transformers. New Laboratory facilities completed for use in insulation development and magnetic field studies. SFO Bushing developed for use on transformers in GIS substations.
- 1973 Aluminum condenser bushings. 1,300,000 KVA, 345 KV transformer shipped.
- 1974 Order received for three 1100 KV transformers for prototype substation.
- 1975 Powder coated insulation.

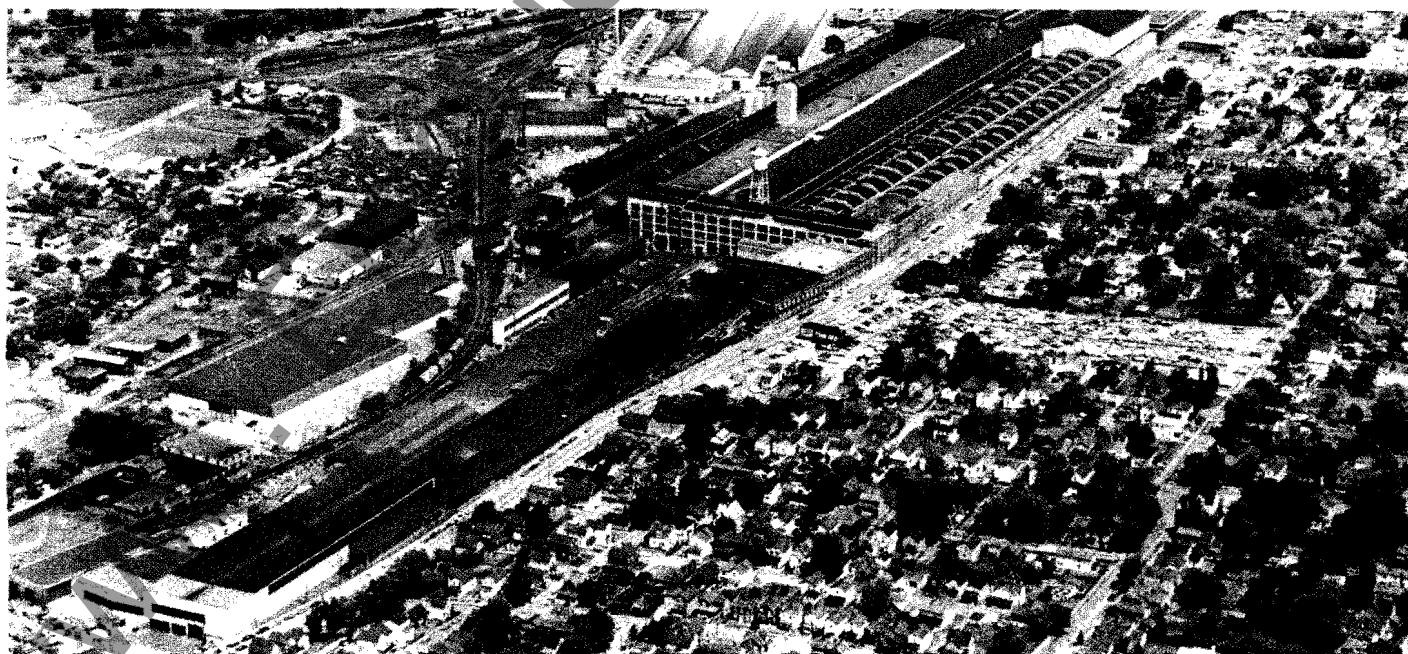

Sharon Transformer Division: Floor space—2,100,000 square feet, overall length—one mile, Employees—3,000, Average years service—24.